

DOE-HDBK-1016/2-93
JANUARY 1993

DOE FUNDAMENTALS HANDBOOK

ENGINEERING SYMBOLOGY, PRINTS, AND DRAWINGS

Volume 2 of 2



U.S. Department of Energy
Washington, D.C. 20585

FSC-6910

Distribution Statement A. Approved for public release; distribution is unlimited.

This document has been reproduced directly from the best available copy.

Available to DOE and DOE contractors from the Office of Scientific and Technical Information, P.O. Box 62, Oak Ridge, TN 37831.

Available to the public from the National Technical Information Services, U.S. Department of Commerce, 5285 Port Royal., Springfield, VA 22161.

Order No. DE93012181

ABSTRACT

The *Engineering Symbolology, Prints, and Drawings Handbook* was developed to assist nuclear facility operating contractors in providing operators, maintenance personnel, and technical staff with the necessary fundamentals training to ensure a basic understanding of engineering prints, their use, and their function. The handbook includes information on engineering fluid drawings and prints; piping and instrument drawings; major symbols and conventions; electronic diagrams and schematics; logic circuits and diagrams; and fabrication, construction, and architectural drawings. This information will provide personnel with a foundation for reading, interpreting, and using the engineering prints and drawings that are associated with various DOE nuclear facility operations and maintenance.

Key Words: Training Material, Print Reading, Piping and Instrument Drawings, Schematics, Electrical Diagrams, Block Diagrams, Logic Diagrams, Fabrication Drawings, Construction Drawings, Architectural Drawings

FOREWORD

The *Department of Energy (DOE) Fundamentals Handbooks* consist of ten academic subjects, which include Mathematics; Classical Physics; Thermodynamics, Heat Transfer, and Fluid Flow; Instrumentation and Control; Electrical Science; Material Science; Mechanical Science; Chemistry; Engineering Symbology, Prints, and Drawings; and Nuclear Physics and Reactor Theory. The handbooks are provided as an aid to DOE nuclear facility contractors.

These handbooks were first published as Reactor Operator Fundamentals Manuals in 1985 for use by DOE category A reactors. The subject areas, subject matter content, and level of detail of the Reactor Operator Fundamentals Manuals were determined from several sources. DOE Category A reactor training managers determined which materials should be included, and served as a primary reference in the initial development phase. Training guidelines from the commercial nuclear power industry, results of job and task analyses, and independent input from contractors and operations-oriented personnel were all considered and included to some degree in developing the text material and learning objectives.

The *DOE Fundamentals Handbooks* represent the needs of various DOE nuclear facilities' fundamental training requirements. To increase their applicability to nonreactor nuclear facilities, the Reactor Operator Fundamentals Manual learning objectives were distributed to the Nuclear Facility Training Coordination Program Steering Committee for review and comment. To update their reactor-specific content, DOE Category A reactor training managers also reviewed and commented on the content. On the basis of feedback from these sources, information that applied to two or more DOE nuclear facilities was considered generic and was included. The final draft of each of the handbooks was then reviewed by these two groups. This approach has resulted in revised modular handbooks that contain sufficient detail such that each facility may adjust the content to fit their specific needs.

Each handbook contains an abstract, a foreword, an overview, learning objectives, and text material, and is divided into modules so that content and order may be modified by individual DOE contractors to suit their specific training needs. Each handbook is supported by a separate examination bank with an answer key.

The *DOE Fundamentals Handbooks* have been prepared for the Assistant Secretary for Nuclear Energy, Office of Nuclear Safety Policy and Standards, by the DOE Training Coordination Program. This program is managed by EG&G Idaho, Inc.

OVERVIEW

The *Department of Energy Fundamentals Handbook* entitled *Engineering Symbolology, Prints, and Drawings* was prepared as an information resource for personnel who are responsible for the operation of the Department's nuclear facilities. A basic understanding of engineering prints and drawings is necessary for DOE nuclear facility operators, maintenance personnel, and the technical staff to safely operate and maintain the facility and facility support systems. The information in the handbook is presented to provide a foundation for applying engineering concepts to the job. This knowledge will improve personnel understanding of the impact that their actions may have on the safe and reliable operation of facility components and systems.

The *Engineering Symbolology, Prints, and Drawings* handbook consists of six modules that are contained in two volumes. The following is a brief description of the information presented in each module of the handbook.

Volume 1 of 2

Module 1 - Introduction to Print Reading

This module introduces each type of drawing and its various formats. It also reviews the information contained in the non-drawing areas of a drawing.

Module 2 - Engineering Fluid Diagrams and Prints

This module introduces engineering fluid diagrams and prints (P&IDs); reviews the common symbols and conventions used on P&IDs; and provides several examples of how to read a P&ID.

Module 3 - Electrical Diagrams and Schematics

This module reviews the major symbols and conventions used on electrical schematics and single line drawings and provides several examples of reading electrical prints.

OVERVIEW (Cont.)

Volume 2 of 2

Module 4 - Electronic Diagrams and Schematics

This module reviews electronic schematics and block diagrams. It covers the major symbols used and provides several examples of reading these types of drawings.

Module 5 - Logic Diagrams

This module introduces the basic symbols and common conventions used on logic diagrams. It explains how logic prints are used to represent a component's control circuits. Truth tables are also briefly discussed and several examples of reading logic diagrams are provided.

Module 6 - Engineering Fabrication, Construction, and Architectural Drawings

This module reviews fabrication, construction, and architectural drawings and introduces the symbols and conventions used to dimension and tolerance these types of drawings.

The information contained in this handbook is by no means all encompassing. An attempt to present the entire subject of engineering drawings would be impractical. However, the *Engineering Symbolology, Prints, and Drawings* handbook does present enough information to provide the reader with a fundamental knowledge level sufficient to understand the advanced theoretical concepts presented in other subject areas, and to improve understanding of basic system operation and equipment operations.

**Department of Energy
Fundamentals Handbook**

**ENGINEERING SYMBOLOGY, PRINTS,
AND DRAWINGS
Module 4
Electronic Diagrams and Schematics**

TABLE OF CONTENTS

LIST OF FIGURES ii

LIST OF TABLES iii

REFERENCES iv

OBJECTIVES v

ELECTRONIC DIAGRAMS AND SCHEMATICS 1

 Introduction 1

 Electronic Schematic Drawing Symbology 2

 Examples of Electronic Schematic Diagrams 5

 Reading Electronic Prints, Diagrams, and Schematics 7

 Block Drawing Symbology 12

 Examples of Block Diagrams. 12

 Summary 17

EXAMPLES 18

 Example 1 18

 Example 2 22

 Summary 23

LIST OF FIGURES

| | | |
|-----------|--------------------------------------------------------------------------------------------------------|----|
| Figure 1 | Electronic Symbols | 3 |
| Figure 2 | Electronic Symbols (Continued) | 4 |
| Figure 3 | Example of an Electronic Schematic Diagram | 5 |
| Figure 4 | Comparison of an Electronic Schematic Diagram and its Pictorial Layout Diagram | 6 |
| Figure 5 | Transformer Polarity Markings | 7 |
| Figure 6 | Schematic Showing Power Supply Connections | 8 |
| Figure 7 | NPN Transistor-Conducting | 9 |
| Figure 8 | NPN Transistor-Nonconducting | 9 |
| Figure 9 | PNP Transistor | 10 |
| Figure 10 | Diode | 10 |
| Figure 11 | Bistable Symbols | 11 |
| Figure 12 | Example Blocks | 12 |
| Figure 13 | Example Block Diagram | 13 |
| Figure 14 | Example of a Combined Drawing, P&ID, Electrical Single Line, and Electronic Block Diagram | 15 |
| Figure 15 | Example Combination Diagram of Electrical Single Line, and Block Diagram | 16 |
| Figure 16 | Example 1 | 19 |
| Figure 17 | Example 2 | 22 |

LIST OF TABLES

NONE

REFERENCES

- ANSI Y14.5M - 1982, Dimensioning and Tolerancing, American National Standards Institute.
- ANSI Y32.2 -1975, Graphic Symbols for Electrical and Electronic Diagrams, American National Standards Institute.
- Gasperini, Richard E., Digital Troubleshooting, Movonics Company; Los Altos, California, 1976.
- Jensen - Helsel, Engineering Drawing and Design, Second Ed., McGraw-Hill Book Company, New York, 1979.
- Lenk, John D., Handbook of Logic Circuits, Reston Publishing Company, Reston, Virginia, 1972.
- Wickes, William E., Logic Design with Integrated Circuits, John Wiley & Sons Inc, 1968.
- Naval Auxiliary Machinery, United States Naval Institute, Annapolis, Maryland, 1951.
- TPC Training Systems, Reading Schematics and Symbols, Technical Publishing Company, Barrington, Illinois, 1974.
- Arnell, Alvin, Standard Graphical Symbols, McGraw-Hill Book Company, 1963.
- George Mashe, Systems Summary of a Westinghouse Pressurized Water Reactor, Westinghouse Electric Corporation, 1971.
- Zappe, R. W., Valve Selection Handbook, Gulf Publishing Company, Houston, Texas, 1968.

TERMINAL OBJECTIVE

- 1.0 Given a block diagram, print, or schematic, **IDENTIFY** the basic component symbols as presented in this module.

ENABLING OBJECTIVES

- 1.1 **IDENTIFY** the symbols used on engineering electronic block diagrams, prints, and schematics, for the following components.

- | | | | |
|----|----------------------------|-----|------------------------------------|
| a. | Fixed resistor | o. | Fuse |
| b. | Variable resistor | p. | Plug |
| c. | Tapped resistor | q. | Headset |
| d. | Fixed capacitor | r. | Light bulb |
| e. | Variable capacitor | s. | Silicon controlled rectifier (SCR) |
| f. | Fixed inductor | t. | Half wave rectifier |
| g. | Variable inductor | u. | Full wave rectifier |
| h. | Diode | v. | Oscillator |
| i. | Light emitting diode (LED) | w. | Potentiometer |
| j. | Ammeter | x. | Rheostat |
| k. | Voltmeter | y. | Antenna |
| l. | Wattmeter | z. | Amplifier |
| m. | Chassis ground | aa. | PNP and NPN transistors |
| n. | Circuit ground | bb. | Junction |

- 1.2 **STATE** the purpose of a block diagram and an electronic schematic diagram.

Intentionally Left Blank.

ELECTRONIC DIAGRAMS, PRINTS, AND SCHEMATICS

To read and understand an electronic diagram or electronic schematic, the basic symbols and conventions must be understood.

EO 1.1 IDENTIFY the symbols used on engineering electronic block diagrams, prints, and schematics, for the following components.

- | | |
|-------------------------------------------------------------------------------------------------------------------------------------------------------------------------------------------------------------------------------------------------------------------------------------------------------------------------------------------------------------------------------------------------------------------------------|-------------------------------------------------------------------------------------------------------------------------------------------------------------------------------------------------------------------------------------------------------------------------------------------------------------------------------------------------------------------------------------------------------------------------------------------------------------------------------------|
| <p>a. Fixed resistor</p> <p>b. Variable resistor</p> <p>c. Tapped resistor</p> <p>d. Fixed capacitor</p> <p>e. Variable capacitor</p> <p>f. Fixed inductor</p> <p>g. Variable inductor</p> <p>h. Diode</p> <p>i. Light emitting diode (LED)</p> <p>j. Ammeter</p> <p>k. Voltmeter</p> <p>l. Wattmeter</p> <p>m. Chassis ground</p> | <p>n. Circuit ground</p> <p>o. Fuse</p> <p>p. Plug</p> <p>q. Headset</p> <p>r. Light bulb</p> <p>s. Silicon controlled rectifier (SCR)</p> <p>t. Half wave bridge rectifier</p> <p>u. Full wave rectifier</p> <p>v. Oscillator</p> <p>w. Potentiometer</p> <p>x. Rheostat</p> <p>y. Antenna</p> <p>z. Amplifier</p> <p>aa. PNP and NPN transistors</p> <p>bb. Junction</p> |
|-------------------------------------------------------------------------------------------------------------------------------------------------------------------------------------------------------------------------------------------------------------------------------------------------------------------------------------------------------------------------------------------------------------------------------|-------------------------------------------------------------------------------------------------------------------------------------------------------------------------------------------------------------------------------------------------------------------------------------------------------------------------------------------------------------------------------------------------------------------------------------------------------------------------------------|

EO 1.2 STATE the purpose of a block diagram and an electronic schematic diagram.

Introduction

Electronic prints fall into two basic categories, electronic schematics and block diagrams. Electronic schematics represent the most detailed category of electronic drawings. They depict every component in a circuit, the component's technical information (such as its ratings), and how each component is wired into the circuit. Block diagrams are the simplest type of drawing. As the name implies, block diagrams represent any part, component, or system as a simple geometric shape, with each block capable of representing a single component (such as a relay) or an entire system. The intended use of the drawing dictates the level of detail provided by

each block. This chapter will review the basic symbols and conventions used in both types of drawings.

Electronic Schematic Drawing Symbolology

Of all the different types of electronic drawings, electronic schematics provide the most detail and information about a circuit. Each electronic component in a given circuit will be depicted and in most cases its rating or other applicable component information will be provided. This type of drawing provides the level of information needed to troubleshoot electronic circuits.

Electronic schematics are the most difficult type of drawing to read, because they require a very high level of knowledge as to how each of the electronic components affects, or is affected by, an electrical current. This chapter reviews only the symbols commonly used in depicting the many components in electronic systems. Once mastered, this knowledge should enable the reader to obtain a functional understanding of most electronic prints and schematics.

Figure 1 and Figure 2 illustrate the most common electronic symbols used on electronic schematics.

Figure 1 Electronic Symbols

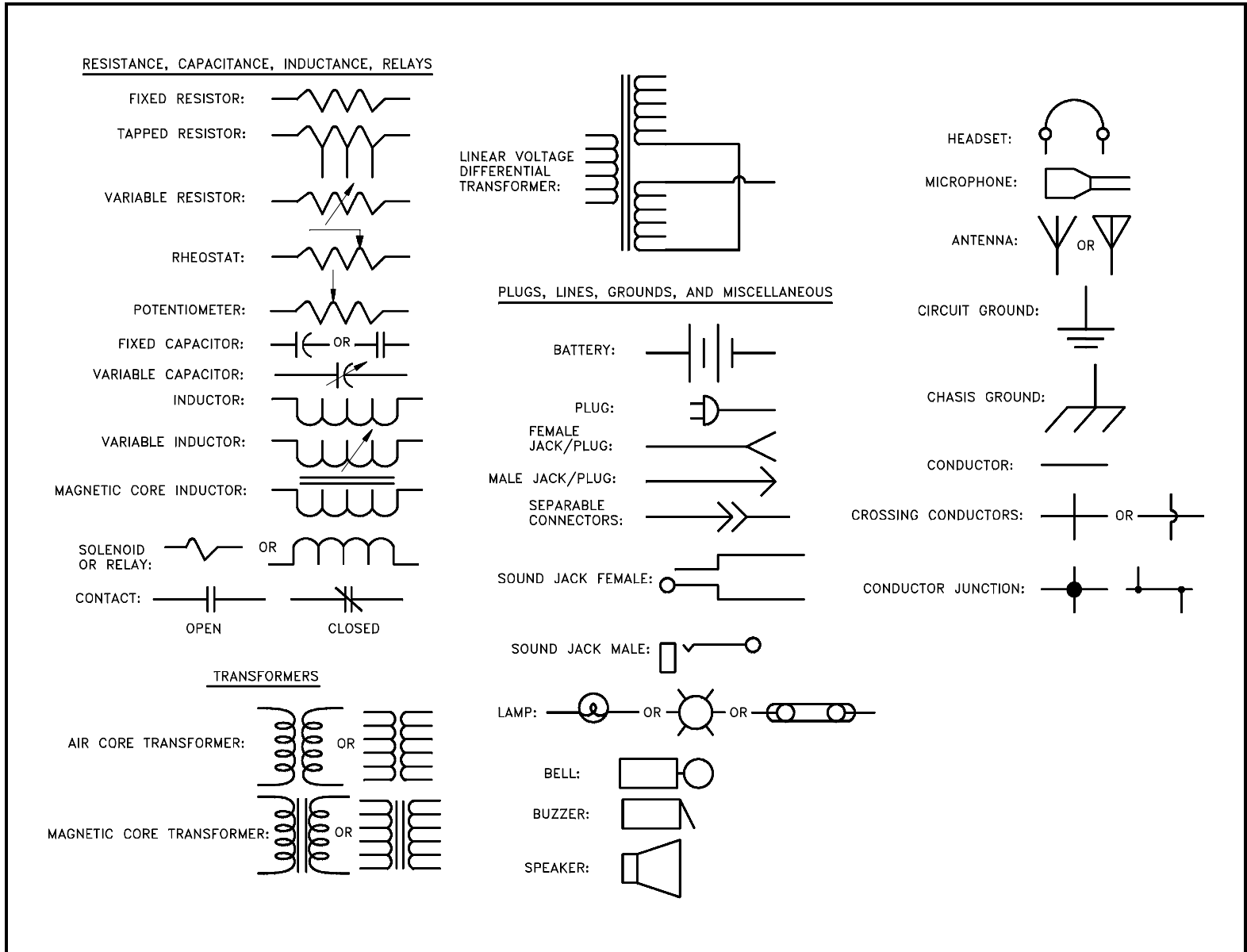

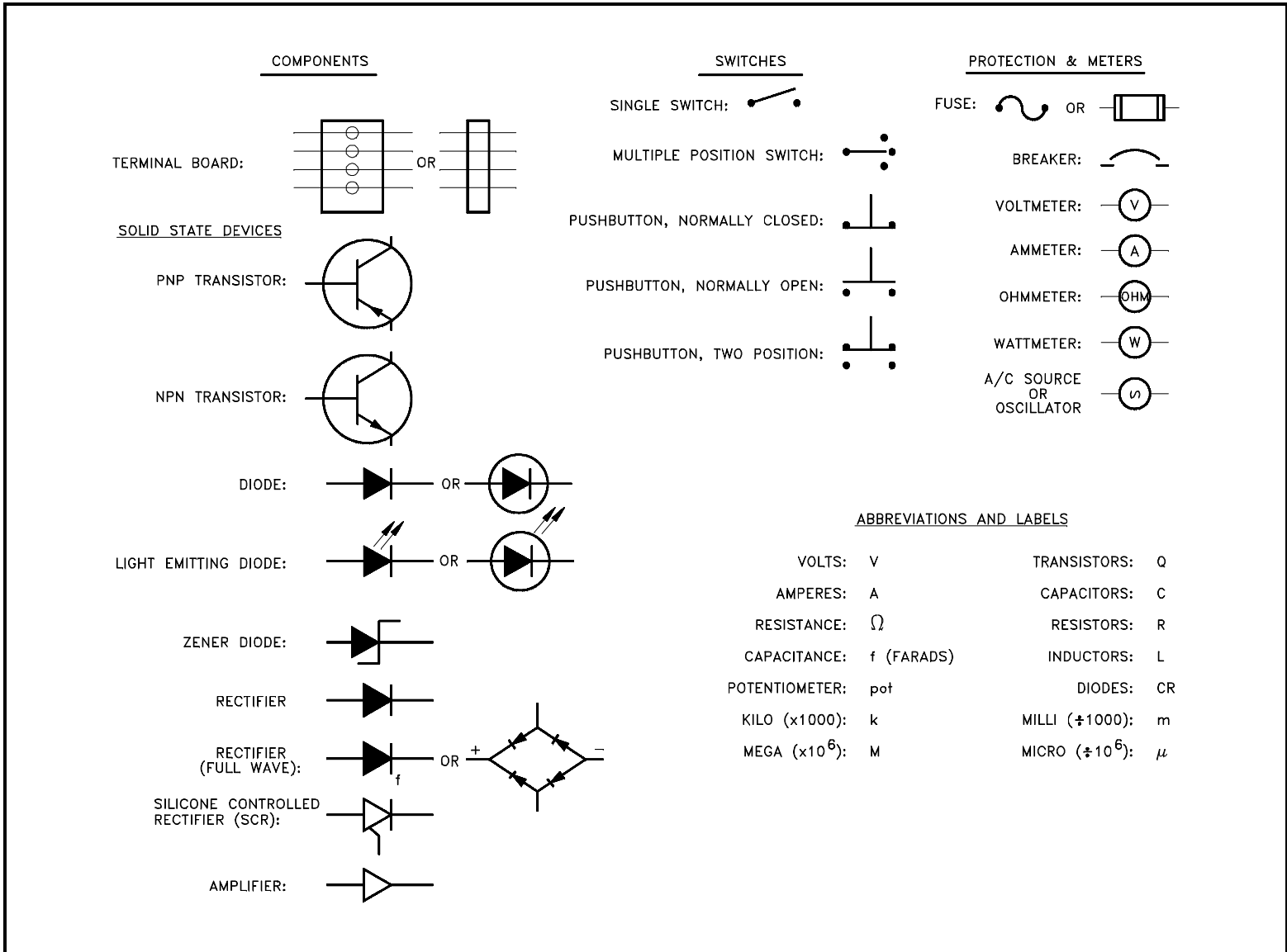

Figure 2 Electronic Symbols (Continued)

Examples of Electronic Schematic Diagrams

Electronic schematics use symbols for each component found in an electrical circuit, no matter how small. The schematics do not show placement or scale, merely function and flow. From this, the actual workings of a piece of electronic equipment can be determined. Figure 3 is an example of an electronic schematic diagram.

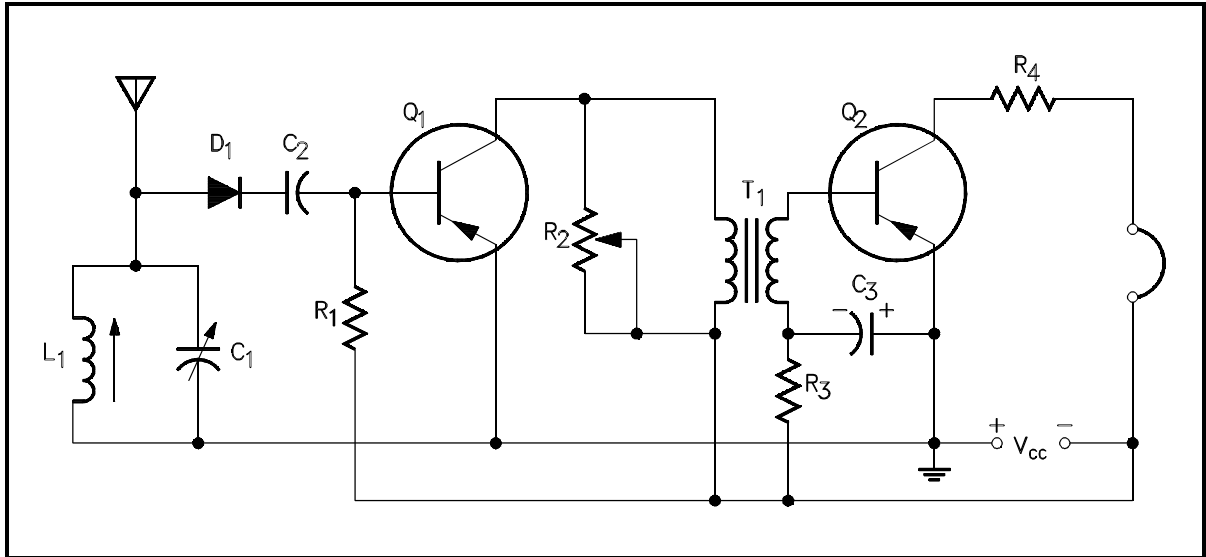

Figure 3 Example of an Electronic Schematic Diagram

A second type of electronic schematic diagram, the pictorial layout diagram, is actually not so much an electronic schematic as a pictorial of how the electronic circuit actually looks. These drawings show the actual layout of the components on the circuit board. This provides a two-dimensional drawing, usually looking down from the top, detailing the components in their location. Shown in Figure 4 is the schematic for a circuit and the same circuit drawn in pictorial or layout format for comparison. Normally the pictorial layout would be accompanied by a parts list.

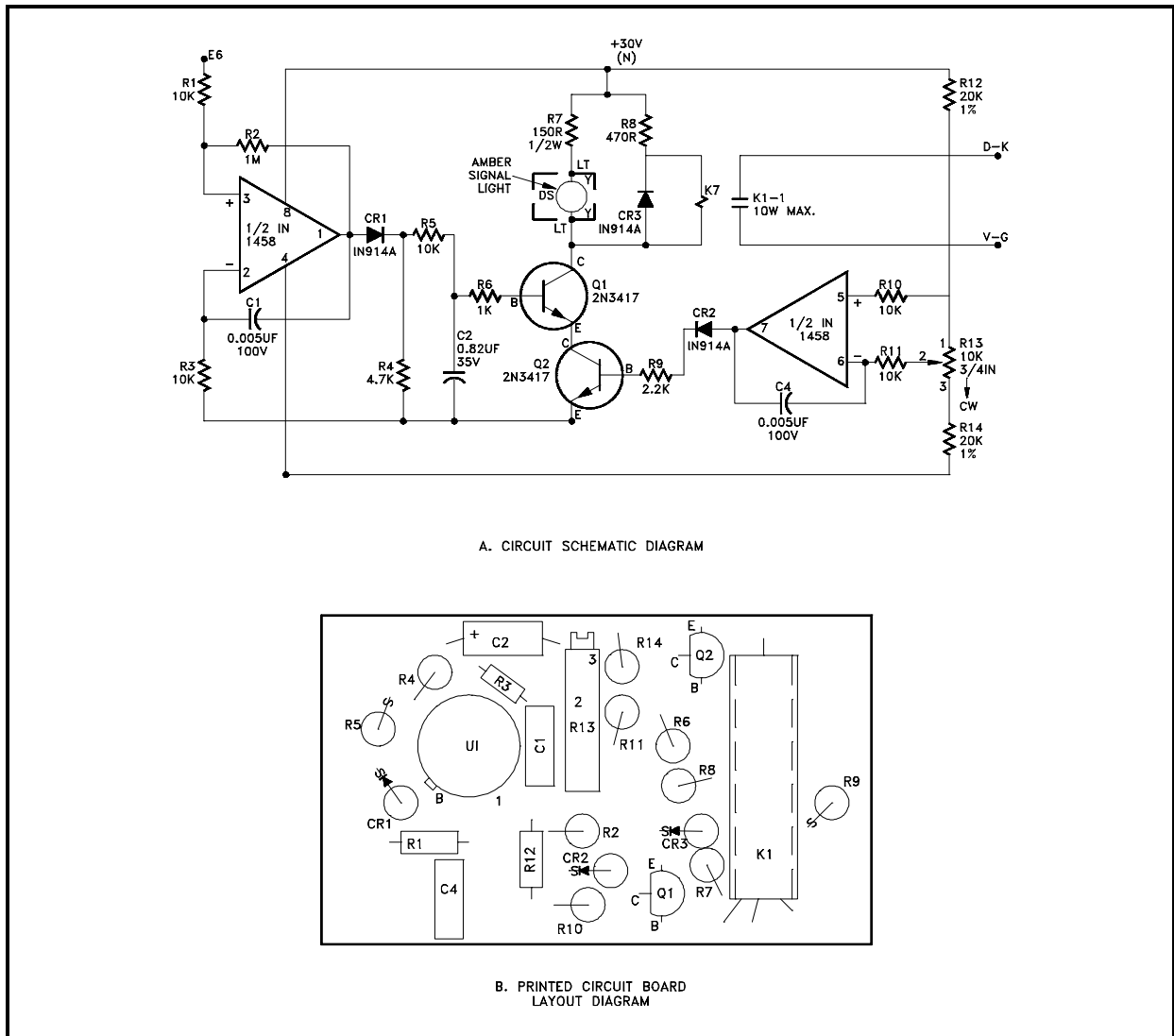

Figure 4 Comparison of an Electronic Schematic Diagram and its Pictorial Layout Diagram

Reading Electronic Prints, Diagrams and Schematics

To properly read prints and schematics, the reader must identify the condition of the components shown and also follow the events that occur as the circuit functions. As with electrical systems, the relays and contacts shown are always in the de-energized condition. Modern electronic systems usually contain few, if any, relays or contacts, so these will normally play a minor role.

Electronic schematics are more difficult to read than electrical schematics, especially when solid state devices are used (The Electronic Science Fundamental Handbook discusses electrical schematics in detail). Knowledge of the workings of these devices is necessary to determine current flow. In this section, only the basics will be covered to assist in reading skills.

The first observation in dealing with a detailed electronic schematic is the source and polarity of power. Generally, power will be shown one of two ways, either as an input transformer, or as a numerical value. When power is supplied by a transformer, polarity marks will aid in determining current flow. In this convention, dots on the primary and secondary indicate current flow into the primary and out of the secondary at a given instant of time. In Figure 5, the current is into the top of the primary and out of the bottom of the secondary.

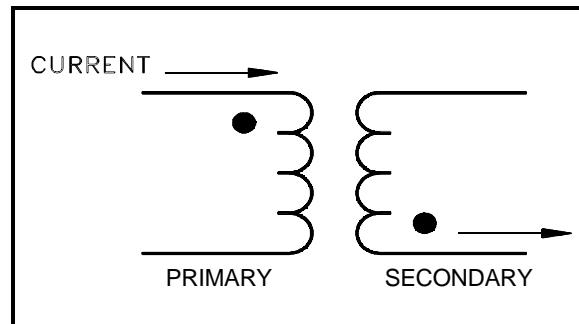

Figure 5 Transformer Polarity Markings

Generally, the electrical power source is indicated at the point where it enters a particular schematic. These values are stated numerically with polarity assigned (+15 volts, -15 volts). These markings are usually at the top and bottom of schematics, but not always. In the example shown in Figure 6, power is shown at both the top and bottom in a circuit using two power sources. Unless specified as an Alternating Current (AC) power source, the voltages can normally be assumed to be Direct Current (DC).

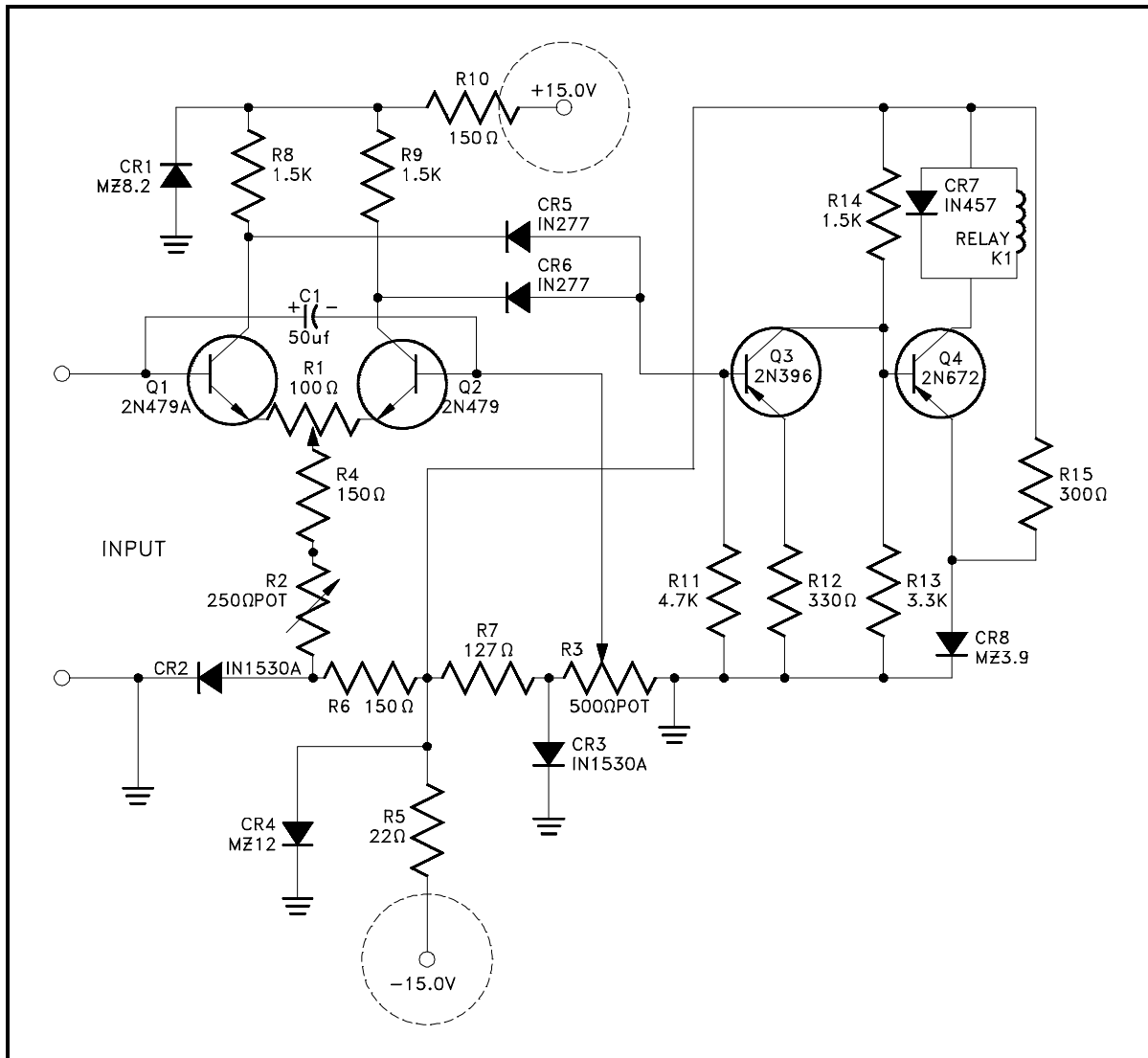

Figure 6 Schematic Showing Power Supply Connections

In any circuit, a ground must be established to create a complete current path. Ground is usually depicted by the use of the ground symbol that was shown previously. The direction of current flow can be determined by observing the polarity of the power supplies. When polarities are shown, current flow can be established and ground may not always be shown.

With the power sources located and the ground point established, operation of the devices can be determined.

The most common semiconductor devices are the transistor and the diode. They are made from materials like silicone and germanium, and have electrical properties intermediate between conductors and insulators. The semiconductor will be one of two varieties, the PNP or NPN. The designation indicates the direction the electrons move through the device. The direction of

the arrow indicates type, as shown in Figure 2. There are, however, many different ways to install a transistor to achieve different operational characteristics. These are too numerous to cover here, so only the most common and basic configuration (the common emitter) will be shown.

Even though transistors contain multiple junctions of p- or n-type material, current flow is generally in the same direction. Using conventional current flow (i.e. from + to -), current will travel through the transistor from most positive to least positive and in the direction of the arrow on the emitter. In Figure 7, the transistor has a positive power supply with ground on the emitter. If the input is also positive, the transistor will conduct.

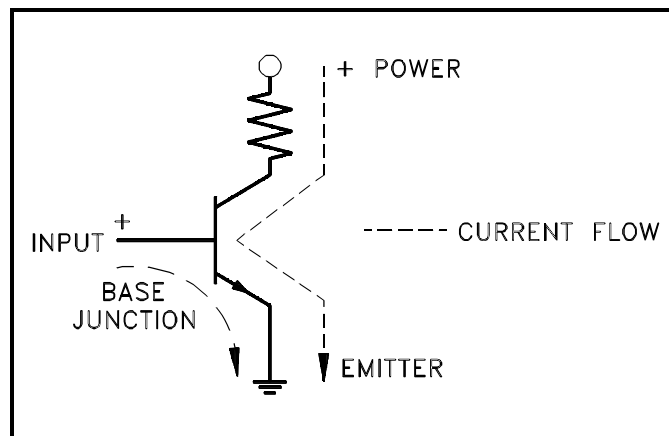

Figure 7 NPN Transistor-Conducting

If the input goes negative, as in Figure 8, the conduction of the device stops because the input, or in this case the base junction, controls the transistor condition. Notice that when current flows, it does so in the direction of the arrow.

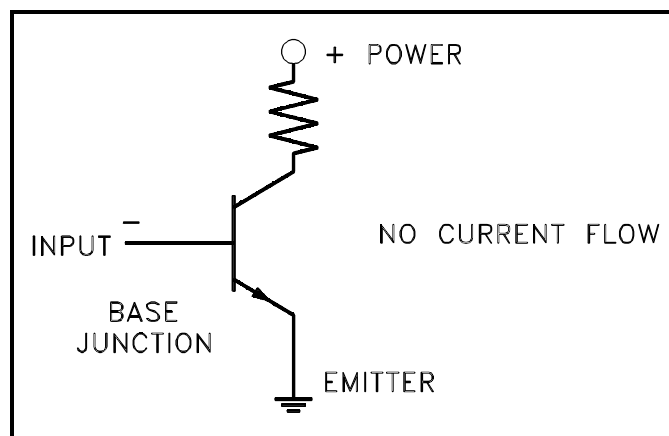

Figure 8 NPN Transistor-Nonconducting

Figure 9 uses a PNP transistor. The same rules apply as above except that this time polarities of power must change to allow current flow.

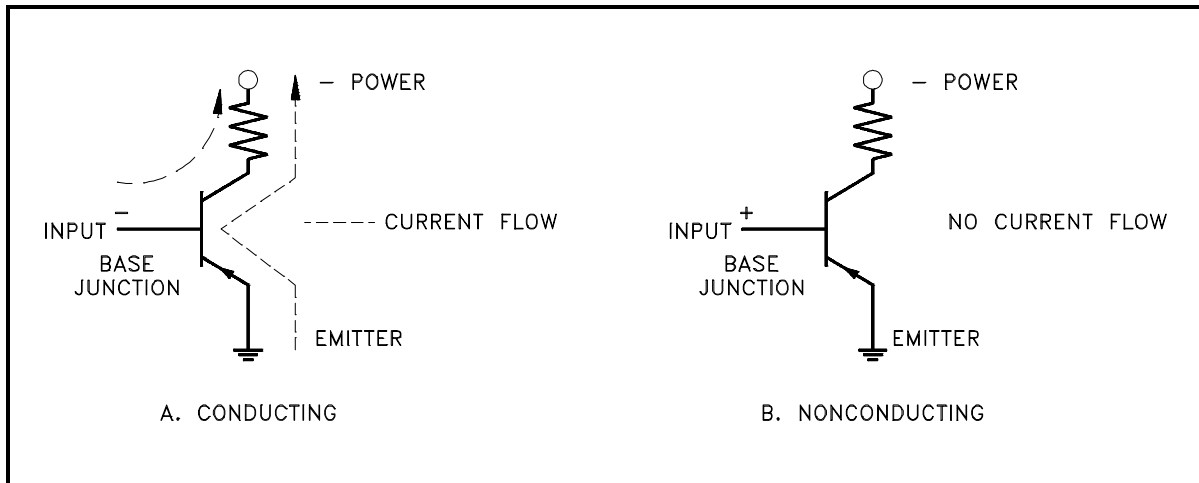

Figure 9 PNP Transistor

The same rules that apply to transistors hold true with diodes. However, diodes are simpler than transistors because they have only one junction and conduct in only one direction, as indicated in Figure 10. The diode symbol, like the transistor symbol, shows the direction of conduction by the direction of the arrow, which is from positive to negative.

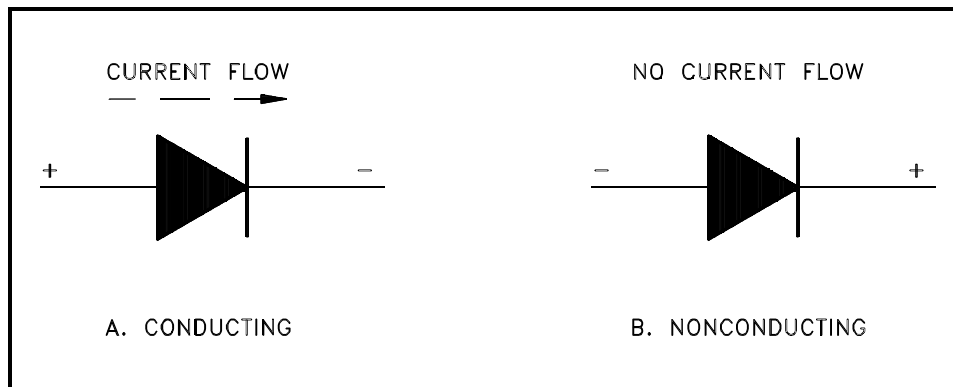

Figure 10 Diode

Although these simple rules will not allow you to read all electronic schematics, they will aid in understanding some of the basic concepts.

An item that may cause confusion when reading electronic prints or schematics is the markings used to show bistable operation. In most cases, bistables will be indicated by a box or circle, as shown in Figure 11 (A). The lines in or around these bistables not only mark them as bistables, but also indicate how they function.

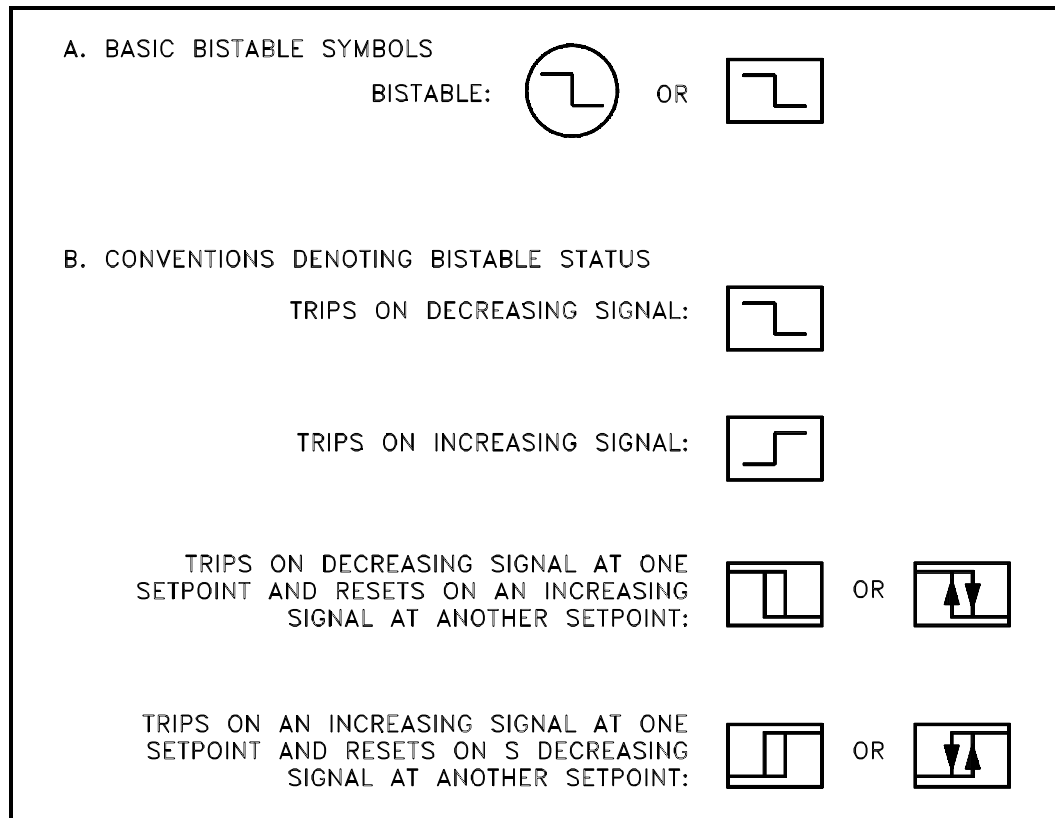

Figure 11 Bistable Symbols

Figure 11 (B) shows the various conventions used to indicate bistable operation. Commonly, one circuit will interface with other circuits, which requires a method that allows the reader to follow one wire or signal path from the first drawing to the second. This may be done in many ways, but generally the line or conductor to be continued will end at a terminal board. This board will be labeled and numbered with the continuation drawing indicated (a separate drawing may exist for each line). With the next drawing in hand, only the terminal board that matches the previous number needs to be found to continue. In cases where terminal boards are not used, the conductor should end with a number (usually a single digit) and also the next drawing number. To assist in locating the continuation, coordinates are provided on some drawings that indicate the location of the continuation on the second drawing. The continuation point on the second drawing will also reference back to the first drawing and the coordinates of the continuation.

Block Drawing Symbology

Not all electronics prints are drawn to the level of detail depicting the individual resistors and capacitors, nor is this level of information always necessary. These simpler drawings are called block diagrams. Block diagrams provide a means of representing any type of electronic circuit or system in a simple graphic format. Block diagrams are designed to present flow or functional information about the circuit or system, not detailed component data. The symbols shown in Figure 12 are used in block diagrams.

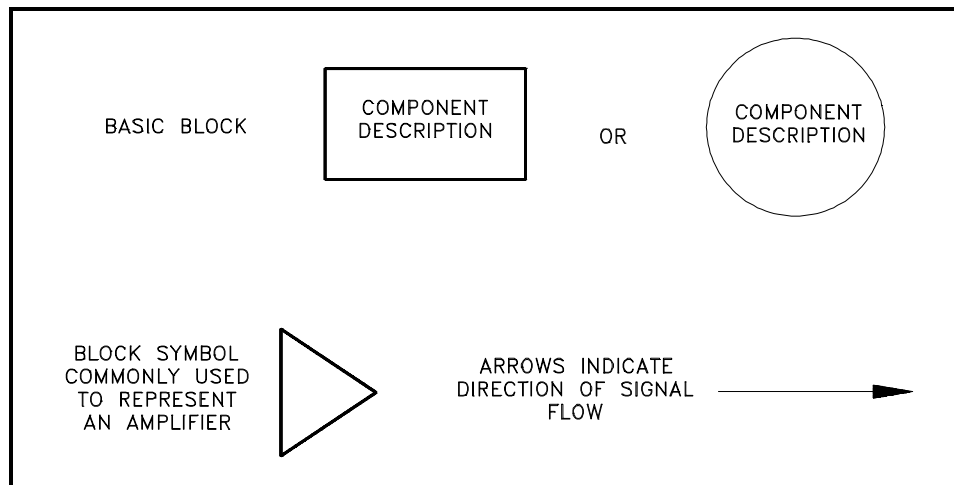

Figure 12 Example Blocks

When block diagrams are used, the basic blocks shown above (Figure 12) can be used for almost anything. Whatever the block represents will be written inside. Note that block diagrams are presented in this chapter with electronic schematics because block diagrams are commonly found with complex schematic diagrams to help present or summarize their flow or functional information. The use of block diagrams is not restricted to electronic circuits. Block diagrams are used extensively to show complex instrument channels and other complex systems when only the flowpath of the signal is important.

Examples of Block Diagrams

The block diagram is the most basic and easiest to understand of all the types of engineering prints. It consists of simple blocks that can represent as much, or as little, as desired. An example of a block diagram is shown in Figure 13.

This particular block diagram represents an instrumentation channel used to measure the neutron flux, indicate the measured flux, and generate output signals for use by other systems.

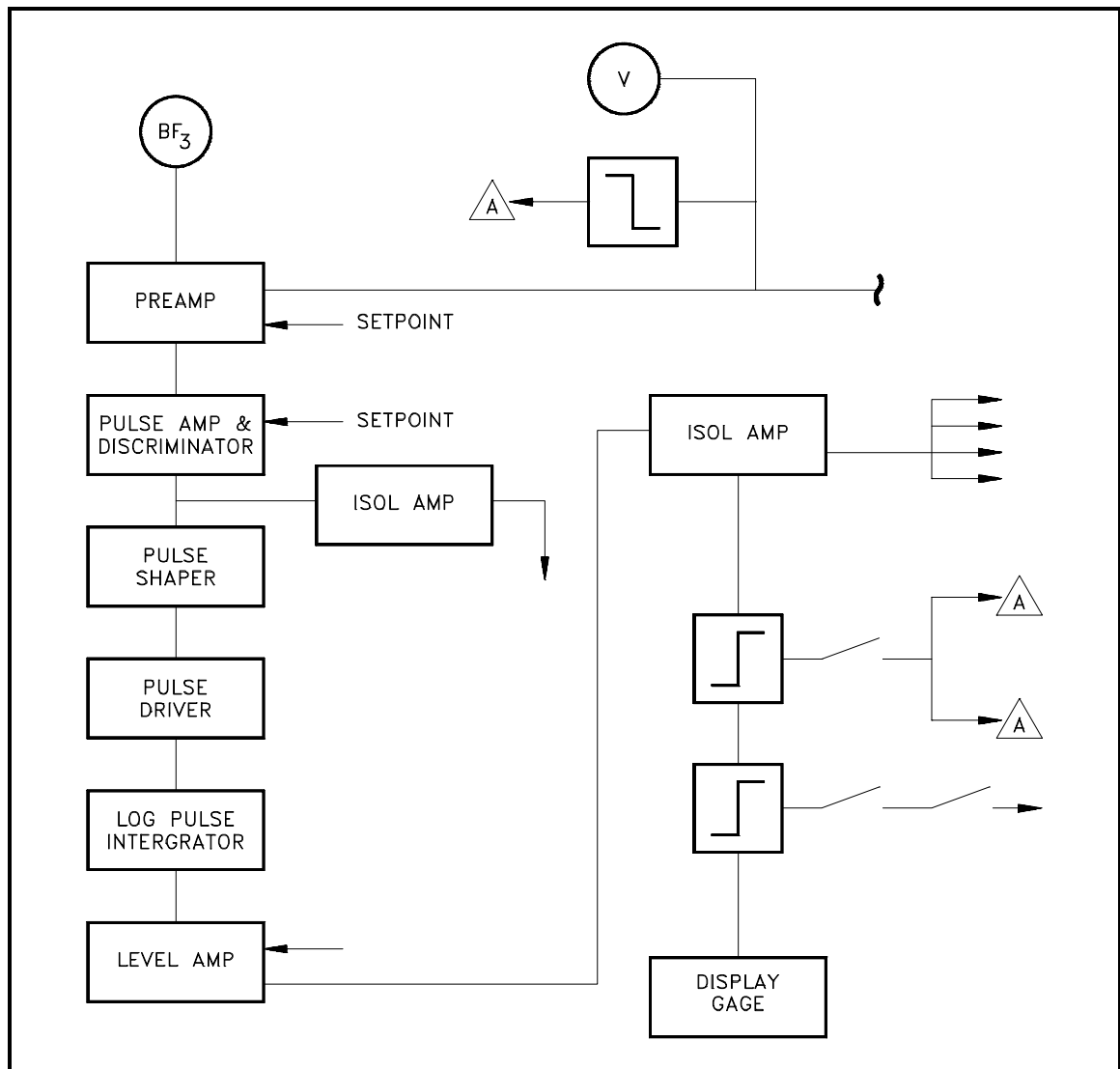

Figure 13 Example Block Diagram

Each block represents a stage in the development of a signal that is used to display on the meter at the bottom or to send to systems outside the bounds of the drawing. Notice that not all blocks are equal. Some represent multiple functions, while others represent only a simple stage or single bistable circuit in a larger component. The creator of the block diagram decides the content of each block based on the intended use of the drawing.

Each of the type of drawing reviewed in this and previous modules is not always distinct and separate. In many cases, two or more types of drawings will be combined into a single print. This allows the necessary information to be presented in a clear and concise format.

Figure 14 provides a sample illustration of how the various types of drawings can be combined. In this example, mechanical symbols are used to represent the process system and the valves controlled by the electrical circuit; electrical single line symbols are used to show the solenoid relays and contacts used in the system; and electronic block symbols are used for the controllers, summers, I/P converter, and bistables.

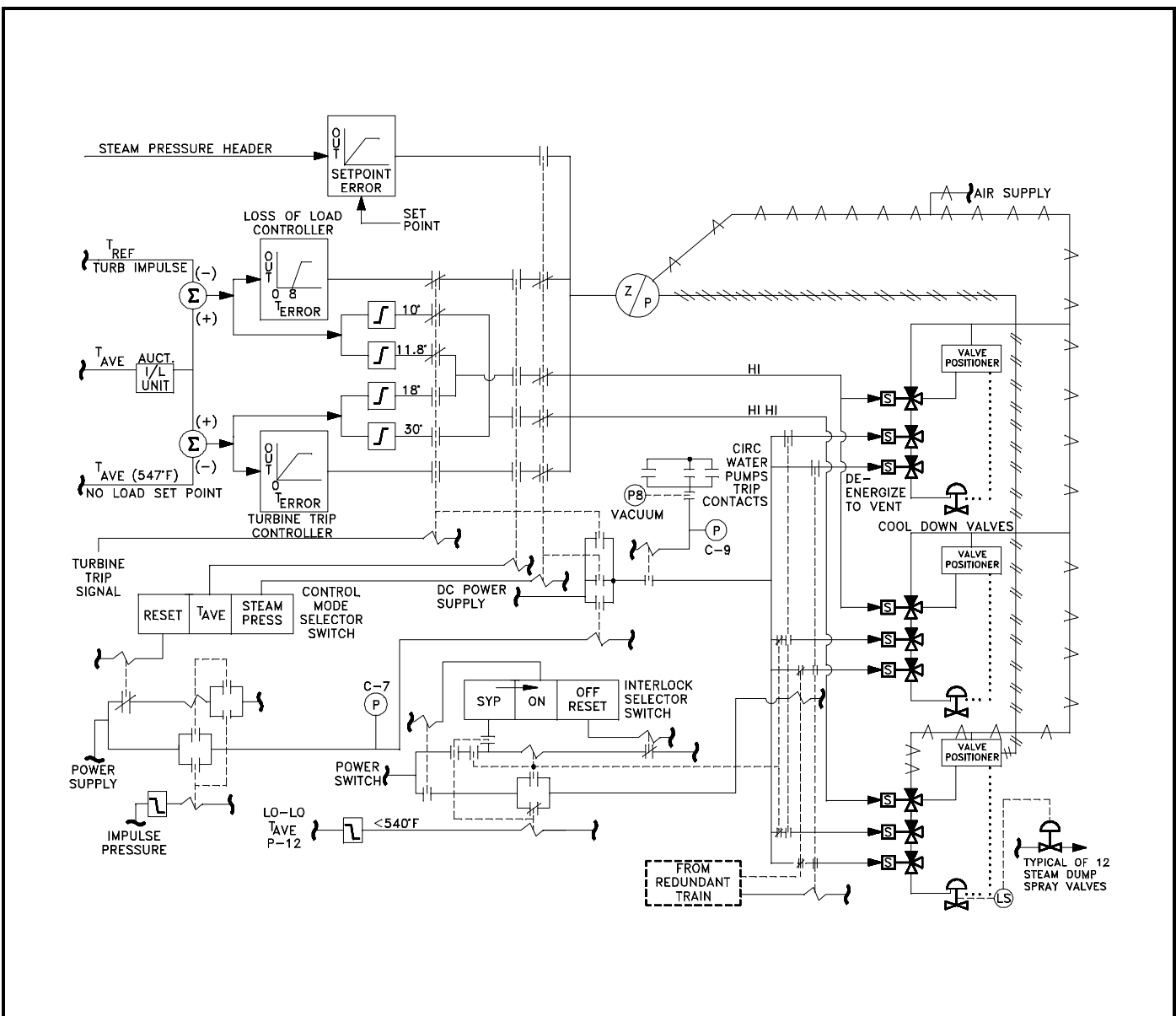

Figure 14 Example of a Combined Drawing, P&ID, Electrical Single Line, and Electronic Block Diagram

Figure 15 illustrates the use of an electronic block diagram combined with an electrical single line diagram. This drawing represents a portion of the generator protection circuitry of a nuclear power generating plant.

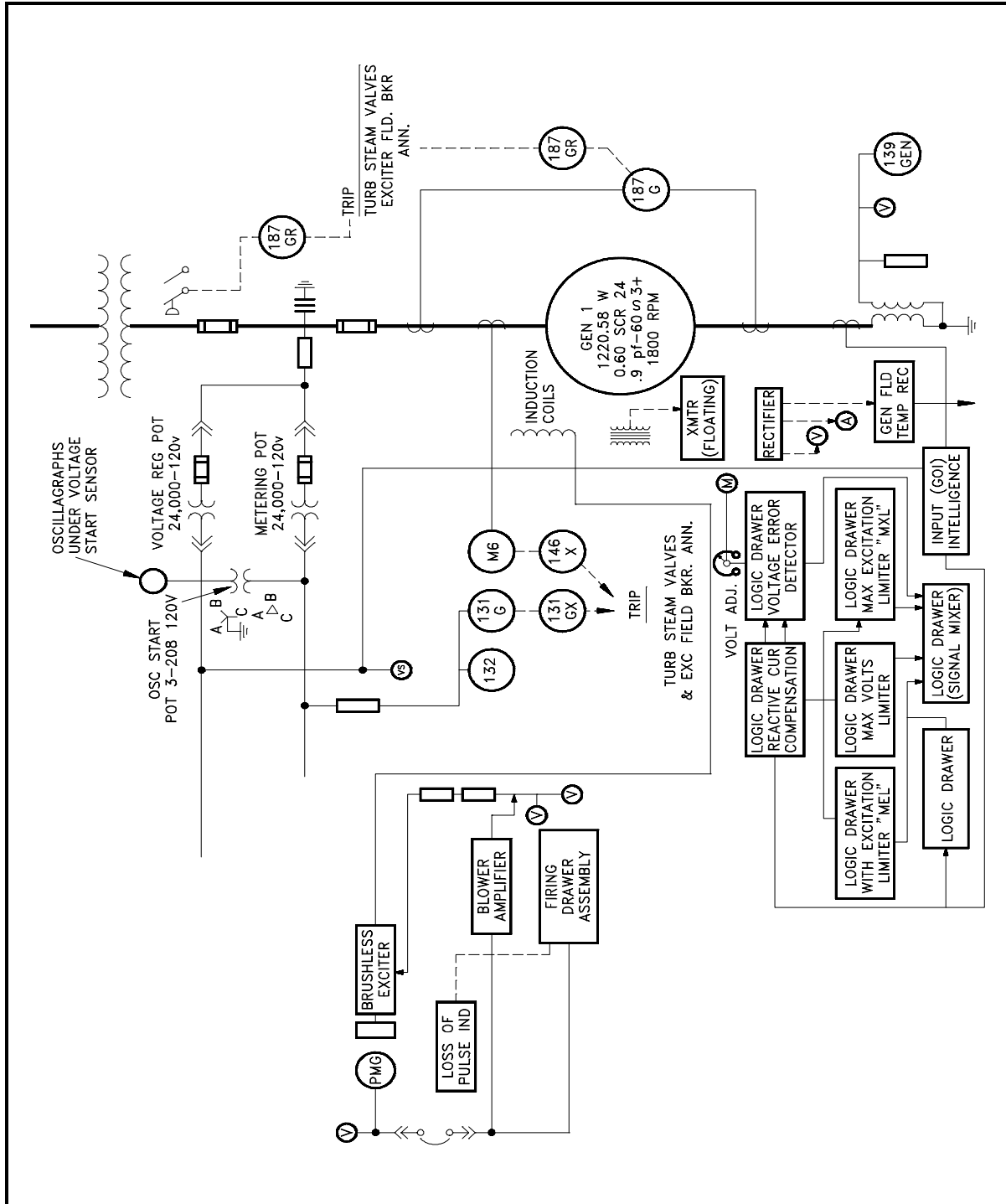

Figure 15 Example Combination Diagram of Electrical Single Line, and Block Diagram

Summary

The important information in this chapter is summarized below.

Electronic Diagrams, Prints, and Schematics Summary

- This chapter covered the common symbols used to represent the basic electronic components used on electronic diagrams, prints, and schematics.
- A block diagram presents the flow or functional information about a circuit, but it is not a detailed depiction of the circuit.
- An electronic schematic diagram presents the detailed information about the circuit, each of its components, and how they are wired into the circuit.

EXAMPLES

This chapter provides several exercises to reinforce the material presented in this module.

Example 1

To assist in your understanding of reading symbols and schematics, answer the following questions concerning the following figures. The answers to each example are given on the page following the questions.

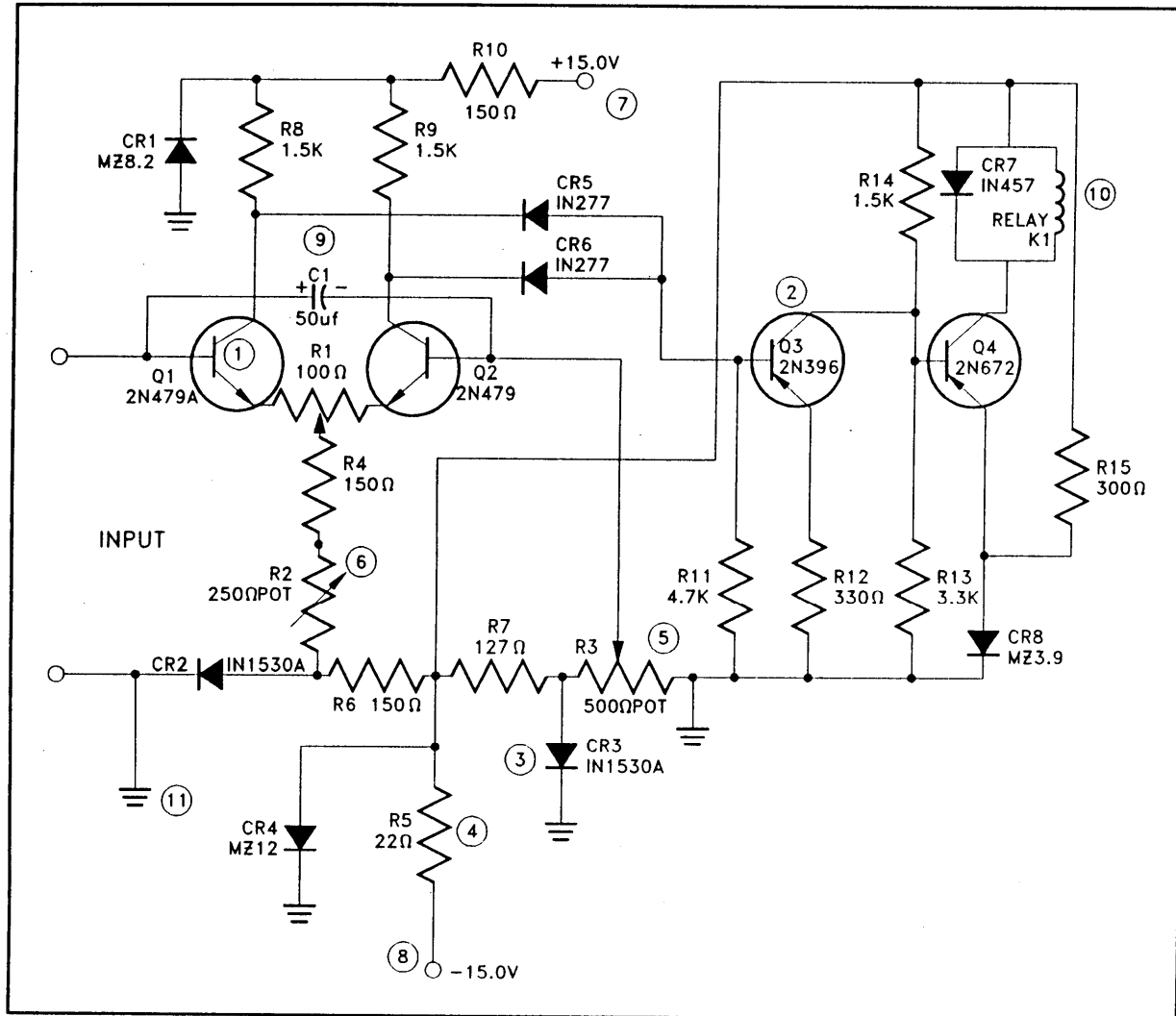

Figure 16 Example 1

Refer to Figure 16 to answer the following:

1. List the number which corresponds to the listed component.
 - ___ a. coil or inductor
 - ___ b. PNP transistor
 - ___ c. diode
 - ___ d. positive power supply
 - ___ e. fixed resistor
 - ___ f. capacitor
 - ___ g. NPN transistor
 - ___ h. variable resistor
 - ___ i. negative power supply
 - ___ j. circuit ground
 - ___ k. potentiometer

2. What is the value of R13? (Include units)

3. With the input to Q1 at -15 volts, will the transistor be conducting or nonconducting? Why?

4. What is the value of C1? (Include units)

Answers to questions on Figure 16

1. a.10 d. 7 g.1 j. 11
 b . 2 e . 4 h.6 k. 5
 c . 3 f . 9 i.8
2. 3.3 kilo-ohm, or 3300 ohms.
3. Nonconducting, because the potential of the base (-15 v) is not positive relative to the emitter (-15 v).
4. 50 microfarads or 0.000050 farads.

Example 2

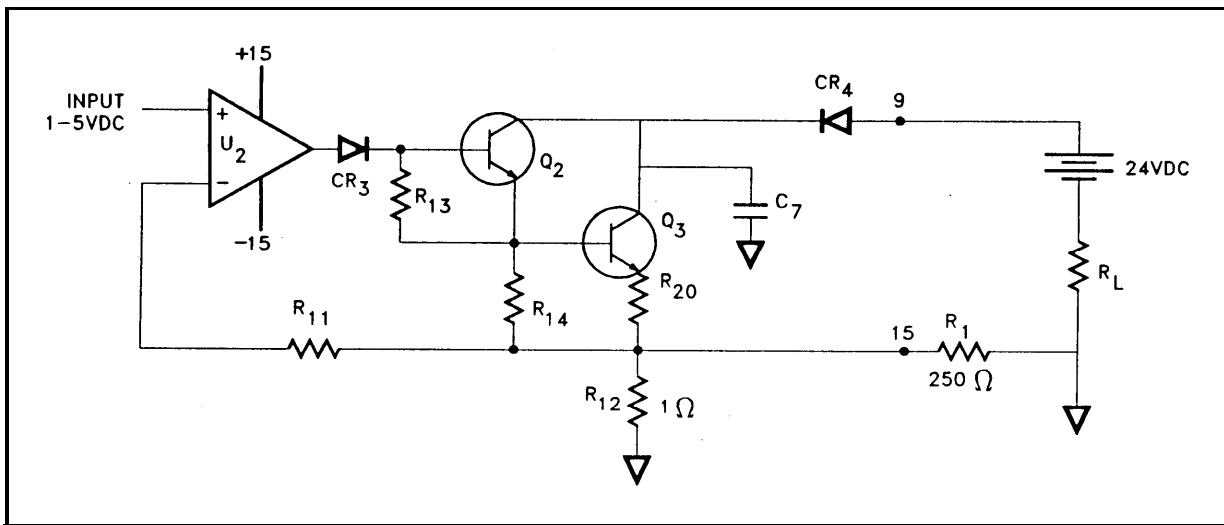

Figure 17 Example 2

Refer to Figure 17 to answer the following:

- a. How many resistors are there in the circuit? _____
- b. How many transistors are there? _____, and are they PNP or NPN transistors?
- c. What is CR₄? _____
- d. How many power supplies are there feeding the circuit and its components? _____
- e. How many capacitors are in the circuit? _____
- f. Q₂ will conduct when the output of U₂ is a positive or negative voltage?

Answers to questions on Figure 17

- a. Seven resistors, R11, R13, R14, R20, R12, R1, RL
- b. Two, both are NPN type transistors.
- c. Diode
- d. Two power supplies, a 1-5 VDC to the U₂ amplifier and 24 VDC battery in the circuit.
- e. One, C₇
- f. NPN transistors conduct when their base junction is positive

Summary

The important information in this chapter is summarized below.

Exercise Summary

- This chapter reviewed the material presented in this module through practice print reading exercises.

Intentionally Left Blank

**Department of Energy
Fundamentals Handbook**

**ENGINEERING SYMBOLOGY, PRINTS,
AND DRAWINGS**

**Module 5
Logic Diagrams**

TABLE OF CONTENTS

| | |
|--------------------------------------|-----|
| LIST OF FIGURES | ii |
| LIST OF TABLES | iii |
| REFERENCES | iv |
| OBJECTIVES | v |
| ENGINEERING LOGIC DIAGRAMS | 1 |
| Introduction | 1 |
| Symbology | 4 |
| Time Delays | 6 |
| Complex Logic Devices | 8 |
| Summary | 10 |
| TRUTH TABLES AND EXERCISES | 11 |
| Truth Tables | 11 |
| Reading Logic Diagrams | 13 |
| Examples | 13 |
| Example 1 | 14 |
| Example 2 | 16 |
| Summary | 20 |

LIST OF FIGURES

| | | |
|-----------|-------------------------------------------------------------|----|
| Figure 1 | Example of a Pump Start Circuit Schematic Diagram | 2 |
| Figure 2 | Example of Pump Start Circuit as a Logic Diagram | 3 |
| Figure 3 | Basic Logic Symbols | 5 |
| Figure 4 | Conventions for Depicting Multiple Inputs | 5 |
| Figure 5 | COINCIDENCE Gate | 6 |
| Figure 6 | EXCLUSIVE OR and EXCLUSIVE NOR Gates | 6 |
| Figure 7 | Type One Time Delay Device | 7 |
| Figure 8 | Type Two Time Delay Device | 7 |
| Figure 9 | Type Three Time Delay Device | 8 |
| Figure 10 | Symbols for Complex Logic Devices | 9 |
| Figure 11 | Truth Tables | 12 |
| Figure 12 | Logic Gate Status Notation | 13 |
| Figure 13 | Example 1 | 14 |
| Figure 14 | Example 2 | 16 |

LIST OF TABLES

NONE

REFERENCES

- ANSI Y14.5M - 1982, Dimensioning and Tolerancing, American National Standards Institute.
- ANSI Y32.2 - 1975, Graphic Symbols for Electrical and Electronic Diagrams, American National Standards Institute.
- Gasperini, Richard E., Digital Troubleshooting, Movonics Company; Los Altos, California, 1976.
- Jensen - Helsel, Engineering Drawing and Design, Second Ed., McGraw-Hill Book Company, New York, 1979.
- Lenk, John D., Handbook of Logic Circuits, Reston Publishing Company, Reston, Virginia, 1972.
- Wickes, William E., Logic Design with Integrated Circuits, John Wiley & Sons, Inc, 1968.
- Naval Auxiliary Machinery, United States Naval Institute, Annapolis, Maryland, 1951.
- TPC Training Systems, Reading Schematics and Symbols, Technical Publishing Company, Barrington, Illinois, 1974.
- Arnell, Alvin, Standard Graphical Symbols, McGraw-Hill Book Company, 1963.
- George Mashe, Systems Summary of a Westinghouse Pressurized Water Reactor, Westinghouse Electric Corporation, 1971.
- Zappe, R.W., Valve Selection Handbook, Gulf Publishing Company, Houston, Texas, 1968.

TERMINAL OBJECTIVE

- 1.0 Given a logic diagram, **READ** and **INTERPRET** the diagrams.

ENABLING OBJECTIVES

- 1.1 **IDENTIFY** the symbols used on logic diagrams to represent the following components:
- | | |
|-------------------------|-------------------|
| a. AND gate | h. Adder |
| b. NAND gate | i. Time-delay |
| c. COINCIDENCE gate | j. Counter |
| d. OR gate | k. Shift register |
| e. NOR gate | l. Flip-flop |
| f. EXCLUSIVE OR gate | m. Logic memories |
| g. NOT gate or inverter | |
- 1.2 **EXPLAIN** the operation of the three types of time delay devices.
- 1.3 **DEVELOP** the truth tables for the following logic gates:
- | | |
|-------------|----------------------|
| a. AND gate | d. NAND gate |
| b. OR gate | e. NOR gate |
| c. NOT gate | f. EXCLUSIVE OR gate |
- 1.4 **IDENTIFY** the symbols used to denote a logical 1 (or high) and a logical 0 (or low) as used in logic diagrams.
- 1.5 Given a logic diagram and appropriate information, **DETERMINE** the output of each component and the logic circuit.

Intentionally Left Blank.

ENGINEERING LOGIC DIAGRAMS

This chapter will review the symbols and conventions used on logic diagrams.

EO 1.1 IDENTIFY the symbols used on logic diagrams to represent the following components:

- | | | | |
|----|----------------------|----|----------------|
| a. | AND gate | h. | Adder |
| b. | NAND gate | i. | Time-delay |
| c. | COINCIDENCE gate | j. | Counter |
| d. | OR gate | k. | Shift register |
| e. | NOR gate | l. | Flip-flop |
| f. | EXCLUSIVE OR gate | m. | Logic memories |
| g. | NOT gate or inverter | | |

EO 1.2 EXPLAIN the operation of the three types of time delay devices.

Introduction

Logic diagrams have many uses. In the solid state industry, they are used as the principal diagram for the design of solid state components such as computer chips. They are used by mathematicians to help solve logical problems (called boolean algebra). However, their principle application at DOE facilities is their ability to present component and system operational information. The use of logic symbology results in a diagram that allows the user to determine the operation of a given component or system as the various input signals change.

To read and interpret logic diagrams, the reader must understand what each of the specialized symbols represent. This chapter discusses the common symbols used on logic diagrams. When mastered, this knowledge should enable the reader to understand most logic diagrams.

Facility operators and technical staff personnel commonly see logic symbols on equipment diagrams. The logic symbols, called gates, depict the operation/start/stop circuits of components and systems. The following two figures, which use a common facility start/stop pump circuit as an example, clearly demonstrate the reasons for learning to read logic diagrams. Figure 1 presents a schematic for a large pump, and Figure 2 shows the same pump circuit using only logic gates. It is obvious that when the basic logic symbols are understood, figuring out how the pump operates and how it will respond to various combinations of inputs using the logic diagram is fast and easy, as compared to laboriously tracing through the relays and contacts of the schematic diagram for the same information.

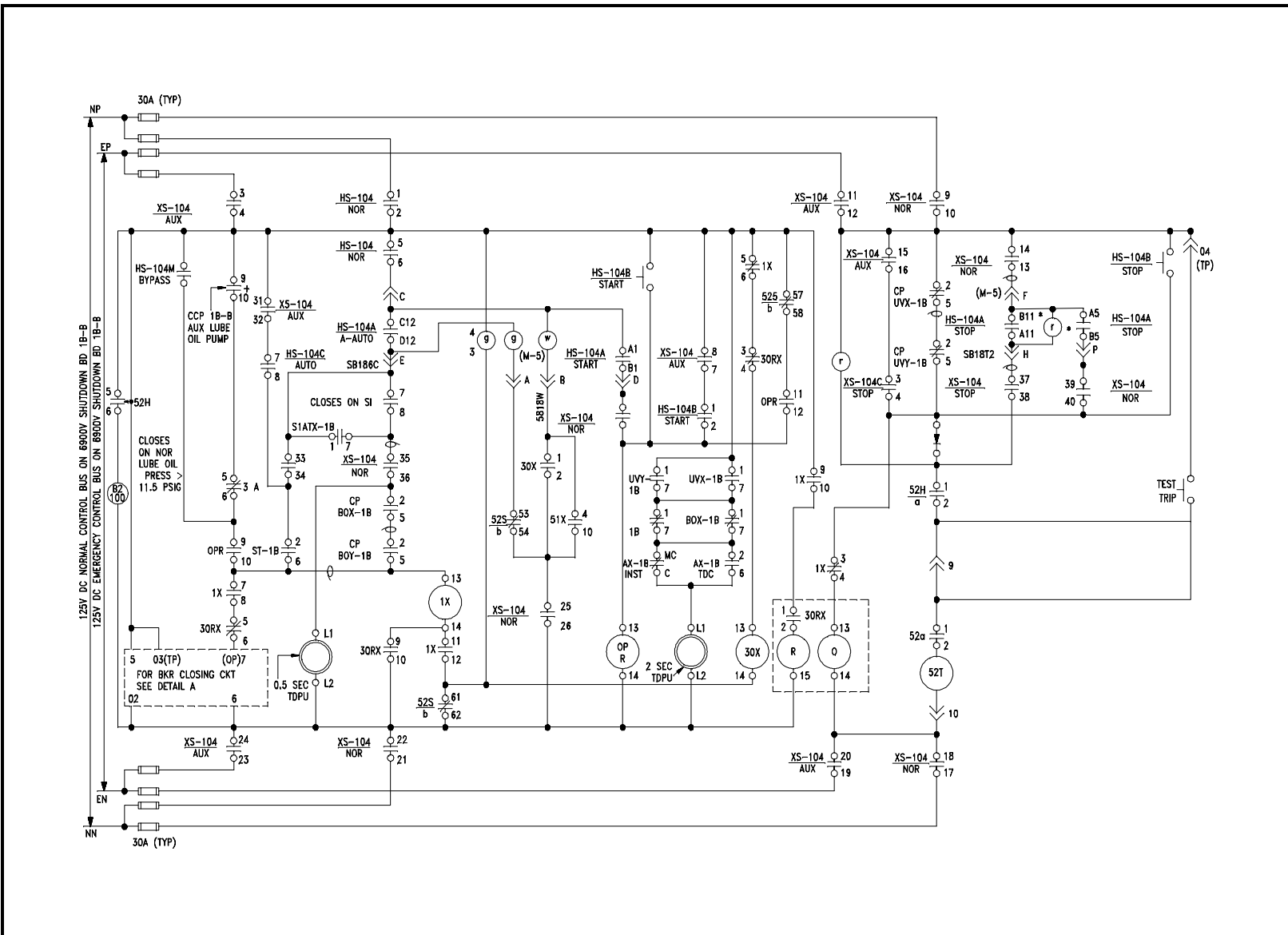

Figure 1 Example of a Pump Start Circuit Schematic Diagram

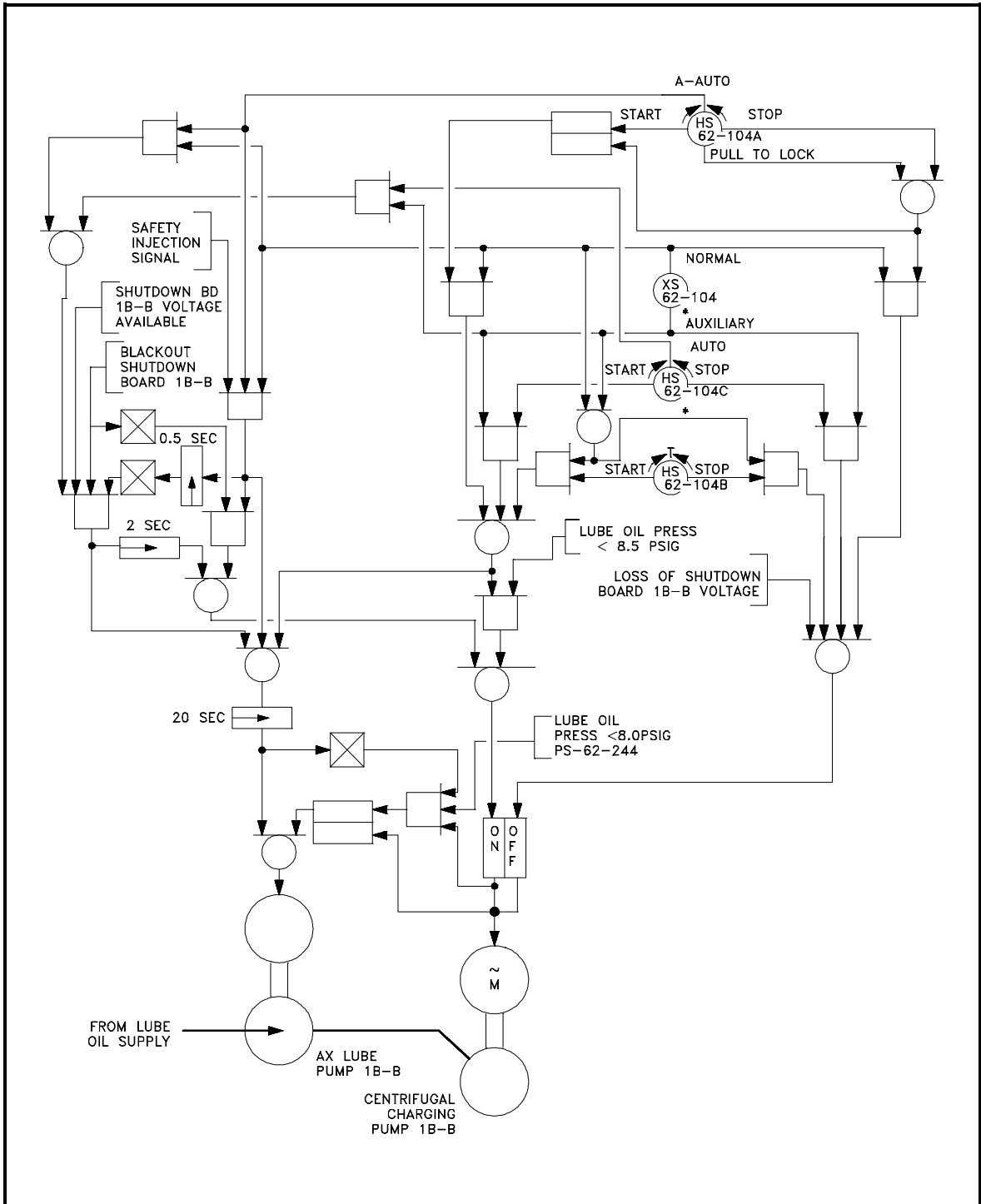

Figure 2 Example of Figure 1 Pump Start Circuit as a Logic Diagram

Symbology

There are three basic types of logic gates. They are AND, OR, and NOT gates. Each gate is a very simple device that only has two states, on and off. The states of a gate are also commonly referred to as high or low, 1 or 0, or True or False, where on = high = 1 = True, and off = low = 0 = False. The state of the gate, also referred to as its output, is determined by the status of the inputs to the gate, with each type of gate responding differently to the various possible combinations of inputs. Specifically, these combinations are as follows.

AND gate - provides an output (on) when all its inputs are on. When any one of the inputs is off, the gate's output is off.

OR gate - provides an output (on) when any one or more of its inputs is on. The gate is off only when all of its inputs are off.

NOT gate - provides a reversal of the input. If the input is on, the output will be off. If the input is off, the output will be on.

Because the NOT gate is frequently used in conjunction with AND and OR gates, special symbols have been developed to represent these combinations. The combination of an AND gate and a NOT gate is called a NAND gate. The combination of an OR gate with a NOT gate is called a NOR gate.

NAND gate - is the opposite (NOT) of an AND gate's output. It provides an output (on) except when all the inputs are on.

NOR gate - is the opposite (NOT) of an OR gate's output. It provides an output only when all inputs are off.

Figure 3 illustrates the symbols covering the three basic logic gates plus NAND and NOR gates. The IEEE/ANSI symbols are used most often; however, other symbol conventions are provided on Figure 3 for information.

| FUNCTION | IEEE/ ANSI | R113J | NEMA | MIL | IEC | ALLEN BRADLEY | G.E. |
|----------|---------------|-------|------|-----|-----|------------------|------|
| AND | | | | | | | |
| NAND | | | | | | | |
| OR | | | | | | | |
| NOR | | | | | | | |
| NOT | | | | | | | |

Figure 3 Basic Logic Symbols

The AND gate has a common variation called a COINCIDENCE gate. Logic gates are not limited to two inputs. Theoretically, there is no limit to the number of inputs a gate can have. But, as the number of inputs increases, the symbol must be altered to accommodate the increased inputs. There are two basic ways to show multiple inputs. Figure 4 demonstrates both methods, using an OR gate as an example. The symbols used in Figure 4 are used extensively in computer logic diagrams. Process control logic diagrams usually use the symbology shown in Figure 2.

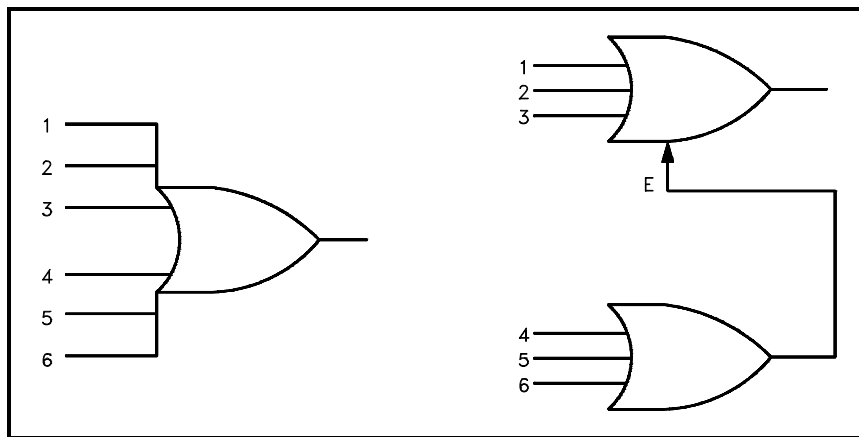

Figure 4 Conventions for Depicting Multiple Inputs

The COINCIDENCE gate behaves like an AND gate except that only a specific number of the total number of inputs needs to be on for the gate's output to be on. The symbol for a COINCIDENCE gate is shown in Figure 5. The fraction in the logic symbol indicates that the AND gate is a COINCIDENCE gate. The numerator of the fraction indicates the number of inputs that must be on for the gate to be on. The denominator states the total number of inputs to the gate.

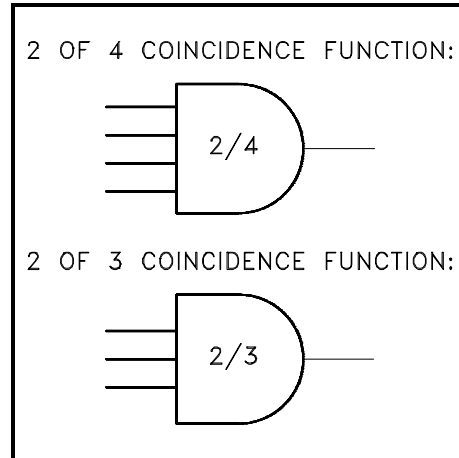

Figure 5 COINCIDENCE Gate

Two variations of the OR gate are the EXCLUSIVE OR and its opposite, the EXCLUSIVE NOR. The EXCLUSIVE OR and the EXCLUSIVE NOR are symbolized by adding a line on the back of the standard OR or NOR gate's symbol, as illustrated in Figure 6.

EXCLUSIVE OR - provides an output (on) when only one of the inputs is on. Any other combination results in no output (off).

EXCLUSIVE NOR - is the opposite (NOT) of an EXCLUSIVE OR gate's output. It provides an output only when all inputs are on or when all inputs are off.

| FUNCTION | IEEE/ ANSI | R113J | NEMA | MIL | IEC | ALLEN BRADLEY | G.E. |
|------------------|---------------|-------|------|-----|-----|------------------|------|
| EXCLUSIVE NOR | | | | | | | |
| EXCLUSIVE OR | | | | | | | |

Figure 6 EXCLUSIVE OR and EXCLUSIVE NOR Gates

Time Delays

When logic diagrams are used to represent start/stop/operate circuits, the diagrams must also be able to symbolize the various timing devices found in the actual circuits. There are three major types of timers. They are 1) the Type-One Time Delay Device, 2) the Type-Two Time Delay Device, and 3) The Type-Three Time Delay Device.

Upon receipt of the input signal, the Type-One Time Delay Device delays the output (on) for the specified period of time, but the output will stop (off) as soon as the input signal is removed, as illustrated by Figure 7. The symbol for this type of timer is illustrated in Figure 7.

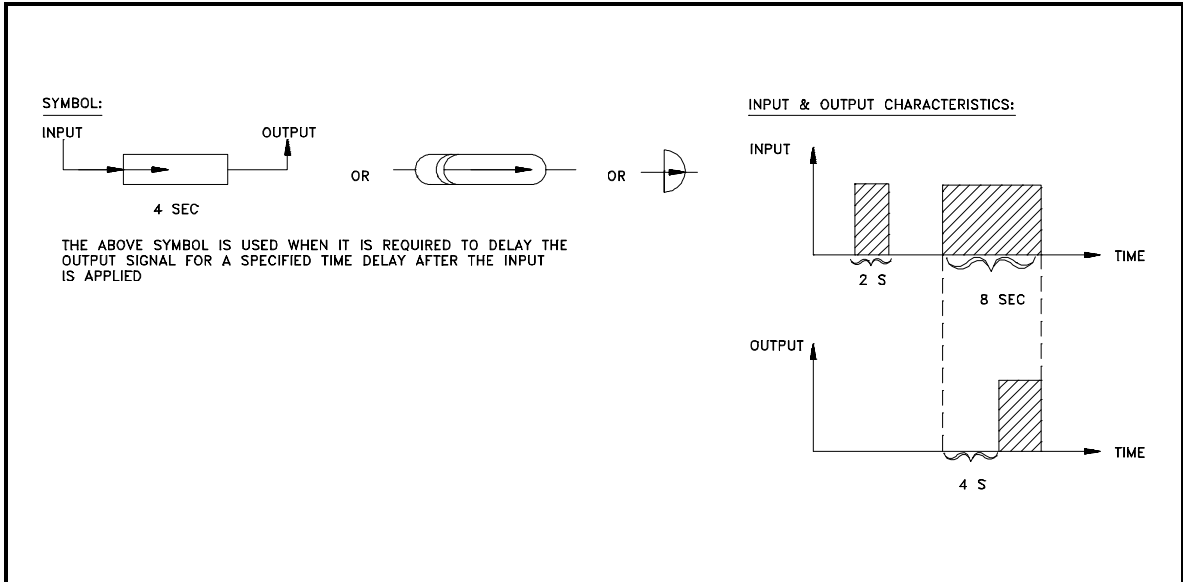

Figure 7 Type One Time Delay Device

The Type-Two Time Delay Device provides an output signal (on) immediately upon receipt of the input signal, but the output is maintained only for a specified period of time once the input signal (off) has been removed. Figure 8 demonstrates the signal response, and Figure 8 illustrates the symbol used to denote this type of timer.

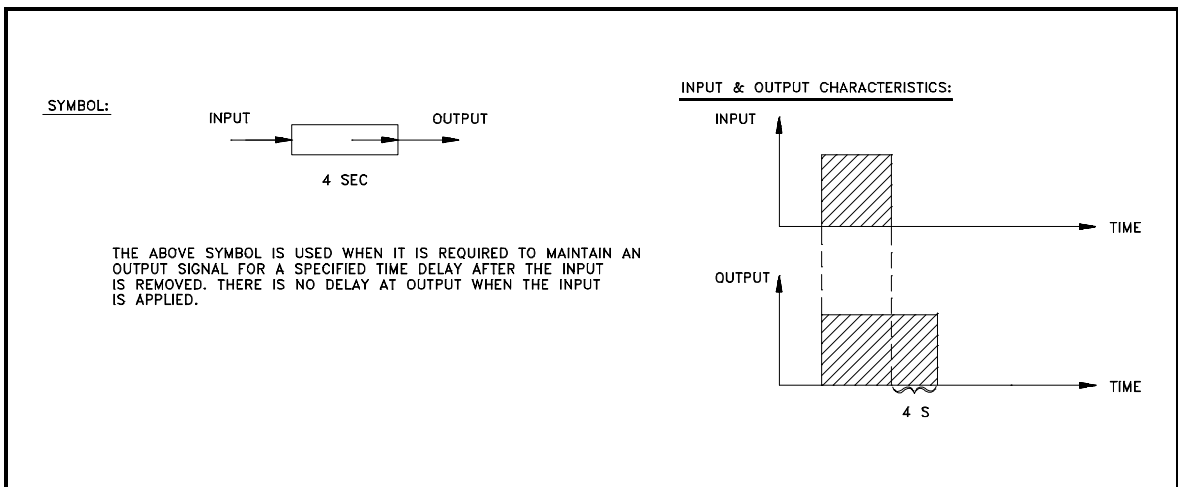

Figure 8 Type Two Time Delay Device

Upon receipt of an input signal, Type-Three Time Delay Devices provide an output signal for a specified period of time, regardless of the duration of the input. Figure 9 demonstrates the signal response and illustrates the symbol used to denote the timer.

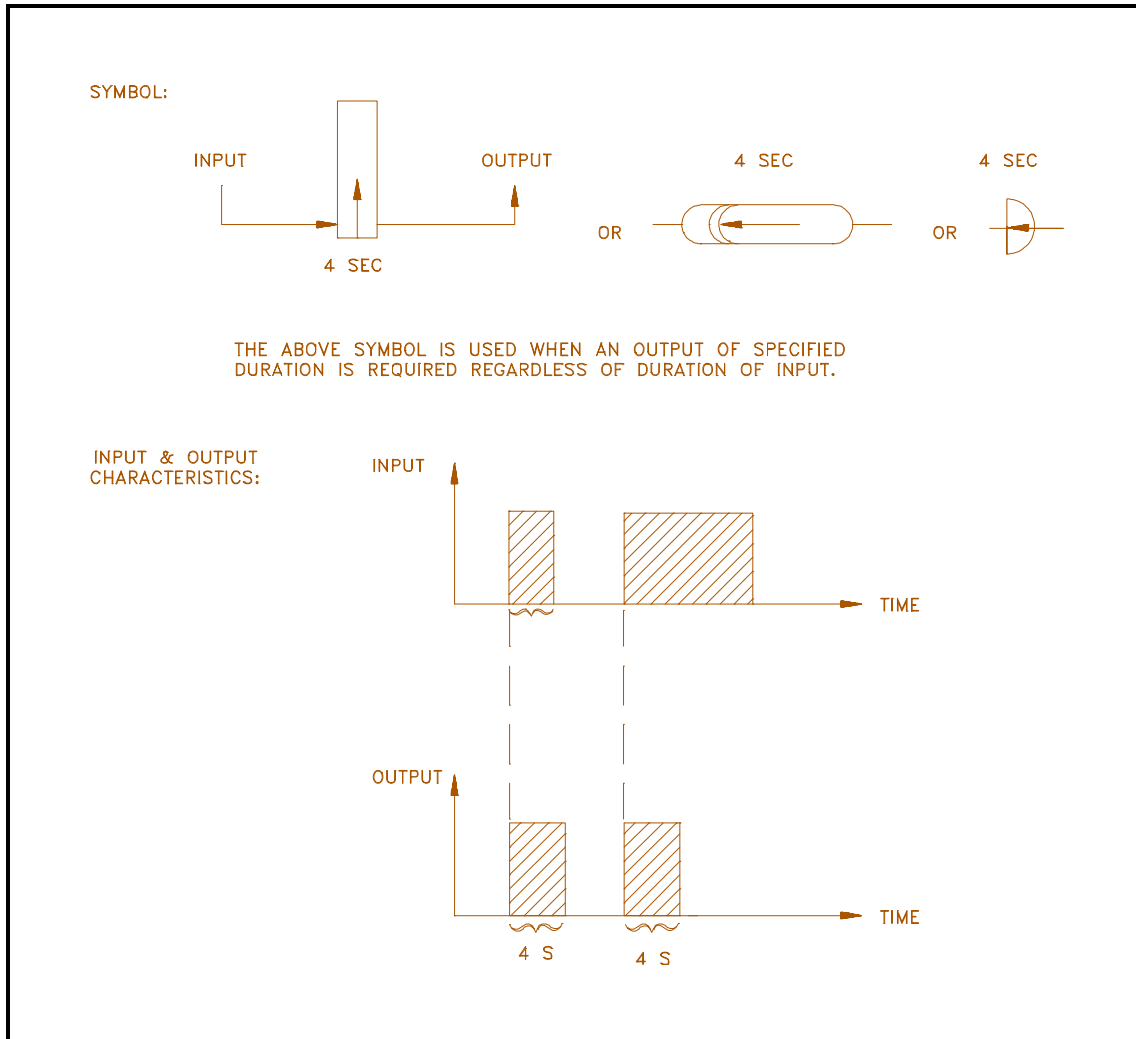

Figure 9 Type-Three Time Delay Device

Complex Logic Devices

In addition to the seven basic logic gates, there are several complex logic devices that may be encountered in the use of logic prints.

Memory devices - In many circuits, a device that can "remember" the last command or the last position is required for a circuit to function. Like the AND and OR gates, memory devices have been designed to work with on/off signals. The two input signals to a memory device are called set and reset. Figure 10 shows the common symbols used for memory devices.

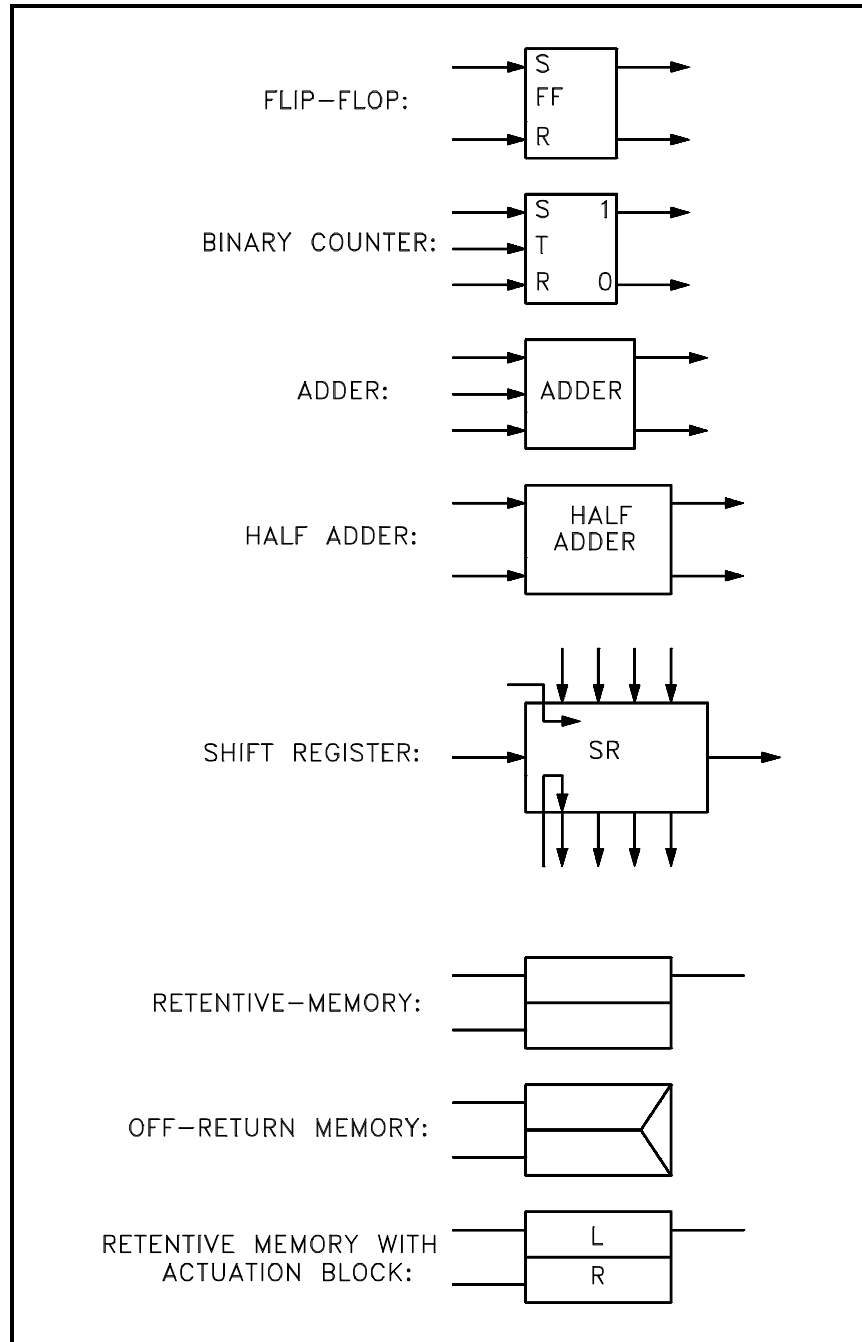

Figure 10 Symbols for Complex Logic Devices

Flop-flop - As the name implies, a flip-flop is a device in which as one or more of its inputs changes, the output changes. A flip-flop is a complex circuit constructed from OR and NOT gates, but is used so frequently in complex circuits that it has its own symbol. Figure 10 shows the common symbol used for a flip-flop.

This device, although occasionally used on component and system type logic diagrams, is principally used in solid state logic diagrams (computers).

Binary counter - Several types of binary counters exist, all of which are constructed of flip-flops. The purpose of a counter is to allow a computer to count higher than 1, which is the highest number a single flip-flop can represent. By ganging flip-flops, higher binary numbers can be constructed. Figure 10 illustrates a common symbol used for a binary counter.

Shift register - Is a storage device constructed of flip-flops that is used in computers to provide temporary storage of a binary word. Figure 10 shows the common symbol used for a shift register.

Half adder - Is a logic circuit that is used in computer circuits to allow the computer to "carry" numbers when it is performing mathematical operations (for example to perform the addition of $9 + 2$, a single 10s unit must be "carried" from the ones column to the tens column). Figure 10 illustrates the symbol used for a half adder.

Summary

The important information in this chapter is summarized below.

Engineering Logic Diagrams Summary

- This chapter reviewed the seven basic symbols used on logic diagrams and the symbols used for six of the more complex logic devices.
- There are three types of time delay devices:

Type One - delays the output signal for a specified period of time

Type Two - only generates an output for the specified period of time

Type Three - receipt of an input signal triggers the device to output a signal for the specified time, regardless of the duration of the input

TRUTH TABLES AND EXERCISES

Truth tables offer a simple and easy to understand tool that can be used to determine the output of any logic gate or circuit for all input combinations.

- EO 1.3 DEVELOP the truth tables for the following logic gates:**
- | | | | |
|-----------|-----------------|-----------|--------------------------|
| a. | AND gate | d. | NAND gate |
| b. | OR gate | e. | NOR gate |
| c. | NOT gate | f. | EXCLUSIVE OR gate |
- EO 1.4 IDENTIFY the symbols used to denote a logical 1 (or high) and a logical 0 (or low) as used in logic diagrams.**
- EO 1.5 Given a logic diagram and appropriate information, DETERMINE the output of each component and the logic circuit.**
-

Truth Tables

When a logic gate has only two inputs, or the logic circuit to be analyzed has only one or two gates, it is fairly easy to remember how a specific gate responds and determine the output of the gate or circuit. But as the number of inputs and/or the complexity of the circuit grows, it becomes more difficult to determine the output of the gate or circuit. Truth tables, as illustrated in Figure 11, are tools designed to help solve this problem. A truth table has a column for the input of each gate and column for the output of each gate. The number of rows needed is based on the number of inputs, so that every combination of input signal is listed (mathematically the number of rows is 2^n , where n = number of inputs). In truth tables, the on and off status of the inputs and outputs is represented using 0s and 1s. As previously stated 0 = off and 1 = on. Figure 11 lists truth tables for the seven basic logic gates. Compare each gate's truth table with its definition given earlier in this module, and verify for yourself that they are stating the same thing.

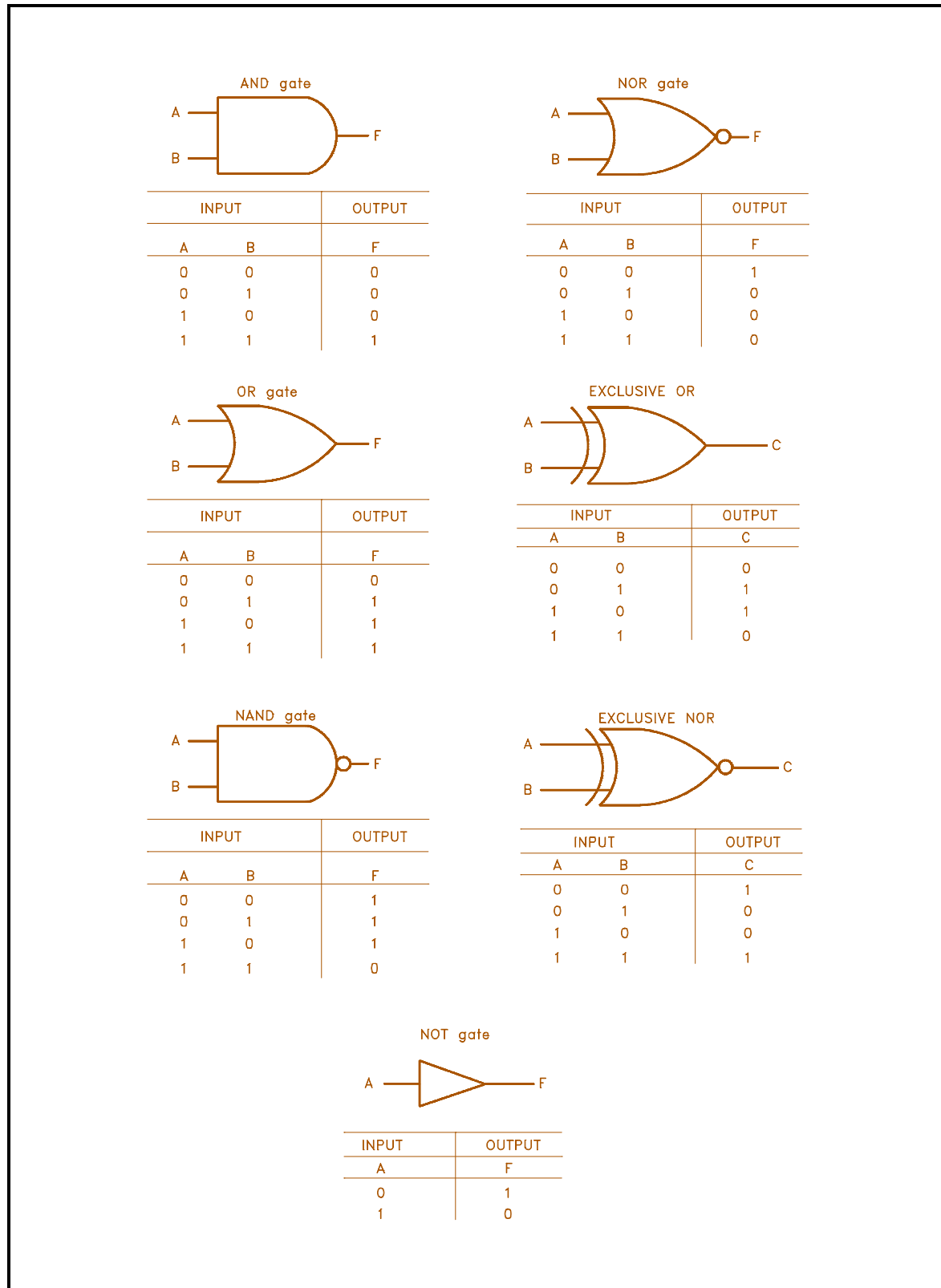

Figure 11 Truth Tables

Reading Logic Diagrams

When reading logic prints the reader usually must decide the input values to each gate. But occasionally the print will provide information as to the normal state of each logic gate. This is denoted by a symbol similar to the bistable symbol, as shown in Figure 12. The symbol is drawn so that the first part of the square wave indicates the normal state of the gate. The second part of the square wave indicates the off-normal state of the gate. Figure 12 also illustrates how this notation is applied.

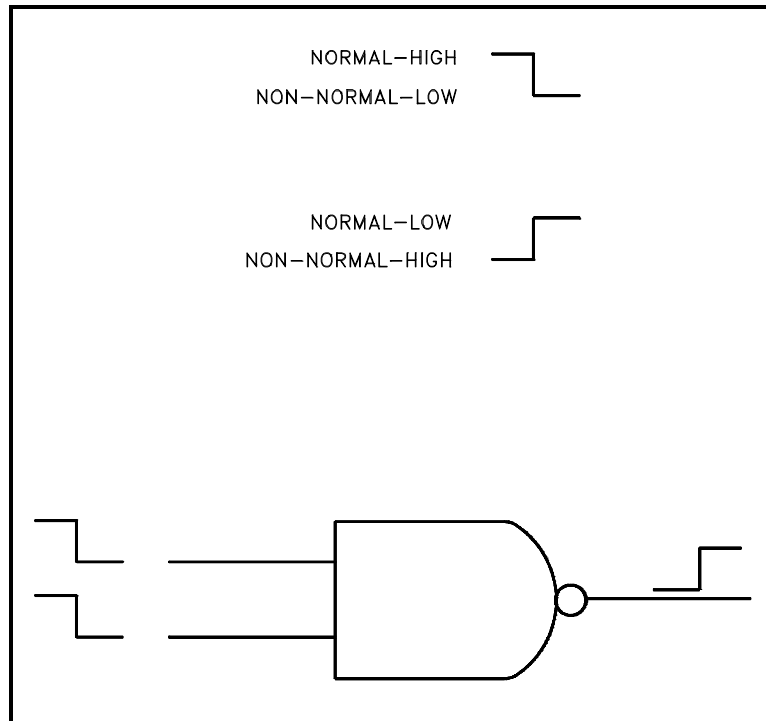

Figure 12 Logic Gate Status Notation

Reading a logic diagram that does not provide information on the status of the gates is not any more difficult. It simply requires the reader to choose the initial conditions, determine the response of the circuits, and modify the inputs as needed. The following exercises will illustrate how to read some simple logic diagrams.

Examples

To aid in understanding the material presented in this module, practice reading the following logic diagrams by answering the questions. The answers are on page 18.

Example 1

Refer to Figure 13 to answer the following questions. Figure 13 illustrates a logic diagram of a simple fan start circuit.

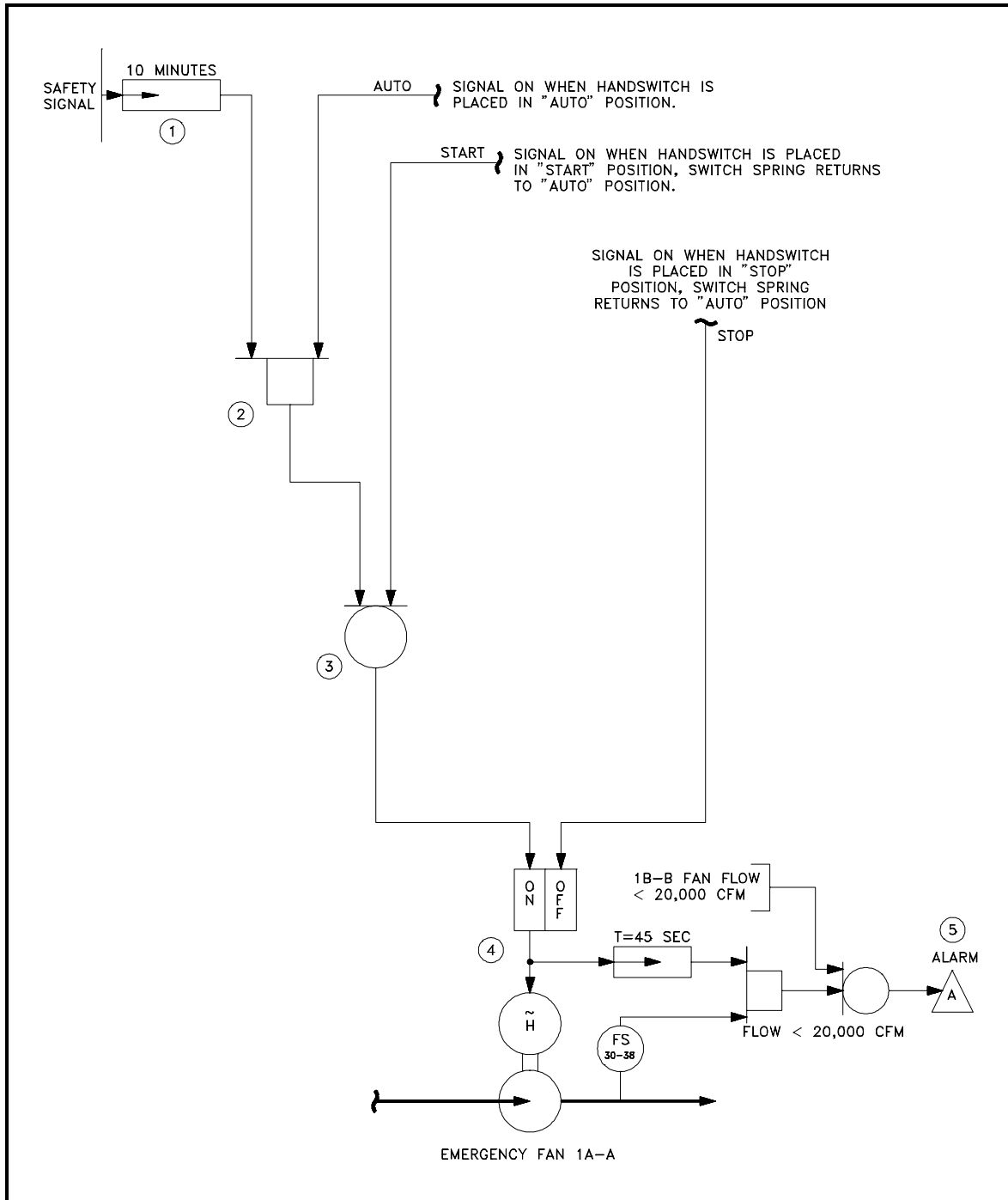

Figure 13 Example 1

1. Identify by number the following logic symbols:

| | | |
|-------|----|------------------|
| _____ | a. | AND |
| _____ | b. | OR |
| _____ | c. | Time delay |
| _____ | d. | Retentive-Memory |

2. How long must the safety signal be present before the time delay (1) will pass an output (on) signal to Gate 2?

3. Under what conditions will Gate 2 turn on?

4. Under what conditions will the low flow alarm (5) sound?

5. Since the control switch is always in the AUTO position (due to the spring return feature), what logic gate keeps the continuous on signal that is generated by the control switch being in the AUTO position from starting the fan? What signal must also be present to allow the AUTO signal to start the fan?

6. If 12 minutes after first receiving a safety signal, with the fan control switch in the AUTO position, the safety signal is removed (off), what will happen to the fan? Why?

7. How many ways can the fan be started? How many ways can the fan be stopped?

Example 2

Refer to Figure 14 to answer the following questions. Figure 14 illustrates a simple valve control circuit. Flow control valve (FCV) 1-147 is an air-operated valve, with its air controlled by flow solenoid valve (FSV) 1-147, which is shown in its de-energized position.

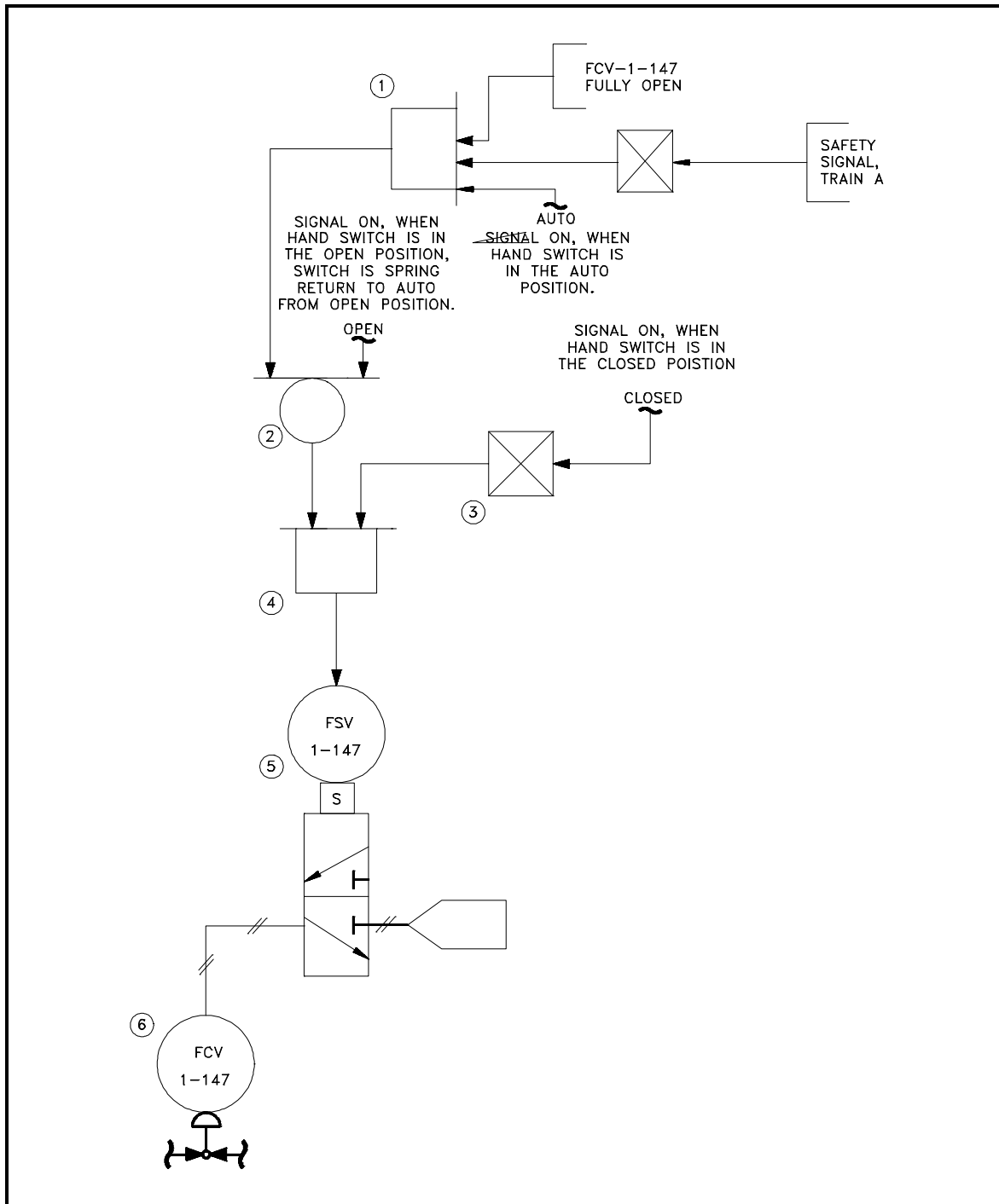

Figure 14 Example 2

Answers to example 1.

1.
 - a. 2
 - b. 3
 - c. 1
 - d. 4

2. The safety signal must be received for greater than 10 minutes before it will pass through the time delay. If the safety signal is removed before 10 minutes has elapsed no signal will be passed to Gate 2.

3. Gate 2 will turn on when the hand-switch is in the AUTO position and a safety signal has been received for greater than 10 minutes.

4. If flow switch (FS) 30-38 senses less than 20,000 cfm, 45 seconds after the fan has started, or the same condition exists on the 1B-B fan, the alarm will sound.

5. AND Gate 2 prevents the on signal from passing until a safety signal is also received (>10 minutes).

6. Ten minutes after receiving the safety signal, the fan started. At 12 minutes, removing the safety signal only removes the continuous start signal to the fan. The fan will continue to run until the hand switch is placed in the stop position. Further, with the removal of the safety signal, the fan will remain stopped when the hand switch spring returns to the AUTO position. Note that if the hand switch is placed in the stop position while the safety signal is present, the fan will stop, but will restart as soon as the switch spring returns to the AUTO position.

7. It can be started by two signals - START and AUTO plus a safety signal. It can be stopped by one signal - STOP (but will only remain stopped if no safety signal is present or the switch is held in the stopped position).

Answers to example number 2.

1.
 - a. 1 & 4
 - b. 2
 - c. 3

2. Right input is - on - this is because the hand control switch is in the AUTO position, and the AUTO switch contacts are made up, resulting in an on signal. Therefore the hand-switch CLOSE position contacts are open, resulting in an off signal. The off signal is reversed in the NOT gate and becomes an on signal.

Left input is - off -. To determine this, the status of the gates feeding the left input must be determined.

Looking at the OR gate (2) above it

The right input to the OR gate is - off - because the hand control switch is in the AUTO position. The OPEN position contacts are not made up, resulting in an off signal.

The left input to the OR gate comes from the AND gate (1) above it.

Looking at the three inputs to the AND gate. The bottom input is - on - because the hand control switch is in the AUTO position and the AUTO contacts are made up, resulting in an on signal.

The middle input to the AND gate is - on - because the NOT gate reverses the off safety signal.

The top input is - off - because the valve is not fully open, resulting in the generation of an off signal. Note this is the signal that, once the valve has traveled to the fully open position, allows the valve to remain open after the hand switch is allowed to spring return to the AUTO position.

Now that all the inputs are known, we can work back through the circuit to determine the status of the left input to the AND gate (4).

Because the one input, the top, to the AND gate (1) is off, the output of the AND gate is off. Therefore, the left input into the OR gate (2) is off. Therefore, because both the left and right inputs to the OR gate (2) are off the output of the OR gate (1) is off.

3. Yes, de-energized is correct because the left input of the AND gate (4) is off and its right input is on. But because it is an AND gate and both its inputs are not on, it will not pass an on signal to the solenoid to energize it.

4. It can be energized one way - the hand switch can be momentarily placed in the OPEN position.

It can be de-energized two ways - the hand switch can be placed in the CLOSE position, or, if the valve is open and a safety signal is received, the valve will automatically close.

5. Yes, the valve can be opened, but it will not remain open when the hand switch is allowed to spring return to the AUTO position. This is because the safety signal's NOT gate removes the on signal that allows the AND gate (1) to output an on signal and energize the solenoid.

Summary

The important information in this chapter is summarized below.

Truth Tables and Exercises Summary

- The normal and off-normal status of each logic gate can be symbolized by the use of a symbol similar to the bistable.

The first part of the square wave indicates the normal state of the gate.

The second part of the square wave indicates the off-normal state of the gate.

- This chapter presented the truth tables for each of the seven basic logic gates.
- This chapter reviewed several examples of how to read logic diagrams of simple pump and valve circuits.

**Department of Energy
Fundamentals Handbook**

**ENGINEERING SYMBOLOGY, PRINTS,
AND DRAWINGS**

Module 6

**Engineering Fabrication, Construction,
and Architectural Drawings**

TABLE OF CONTENTS

| | |
|-------------------------------------------------------------------------------------|-----|
| LIST OF FIGURES | ii |
| LIST OF TABLES | iii |
| REFERENCES | iv |
| OBJECTIVES | v |
| ENGINEERING FABRICATION, CONSTRUCTION, AND ARCHITECTURAL DRAWINGS | 1 |
| Introduction | 1 |
| Dimensioning Drawings | 5 |
| Dimensioning and Tolerance Symbology, Rules, and Conventions | 6 |
| Summary | 12 |
| ENGINEERING FABRICATION, CONSTRUCTION, AND ARCHITECTURAL DRAWING, EXAMPLES | 13 |
| Examples | 13 |
| Example 1 | 13 |
| Example 2 | 14 |
| Example 3 | 15 |
| Summary | 17 |

LIST OF FIGURES

| | | |
|-----------|--------------------------------------------------|----|
| Figure 1 | Example of a Fabrication Drawing | 2 |
| Figure 2 | Example of a Construction Drawing | 3 |
| Figure 3 | Example of an Architectural Drawing | 4 |
| Figure 4 | Types of Dimensioning Lines | 6 |
| Figure 5 | Example of Dimensioning Notation | 7 |
| Figure 6 | Symbology Used in Tolerancing Drawings | 9 |
| Figure 7 | Examples of Tolerance Symbology | 10 |
| Figure 8 | Example of Tolerancing | 11 |
| Figure 9 | Example 1 | 13 |
| Figure 10 | Example 2 | 14 |
| Figure 11 | Example 3 | 15 |

LIST OF TABLES

NONE

REFERENCES

- ANSI Y14.5M - 1982, Dimensioning and Tolerancing, American National Standards Institute.
- ANSI Y32.2 - 1975, Graphic Symbols for Electrical and Electronic Diagrams, American National Standards Institute.
- Gasperini, Richard E., Digital Troubleshooting, Movonics Company; Los Altos, California, 1976.
- Jensen - Helsel, Engineering Drawing and Design, Second Ed., McGraw-Hill Book Company, New York, 1979.
- Lenk, John D., Handbook of Logic Circuits, Reston Publishing Company, Reston, Virginia, 1972.
- Wickes, William E., Logic Design with Integrated Circuits, John Wiley & Sons, Inc, 1968.
- Naval Auxiliary Machinery, United States Naval Institute, Annapolis, Maryland, 1951.
- TPC Training Systems, Reading Schematics and Symbols, Technical Publishing Company, Barrington, Illinois, 1974.
- Arnell, Alvin, Standard Graphical Symbols, McGraw-Hill Book Company, 1963.
- George Mashe, Systems Summary of a Westinghouse Pressurized Water Reactor, Westinghouse Electric Corporation, 1971.
- Zappe, R.W., Valve Selection Handbook, Gulf Publishing Company, Houston, Texas, 1968.

TERMINAL OBJECTIVE

- 1.0 Given an engineering fabrication, construction, or architectural drawing, **READ** and **INTERPRET** basic dimensional and tolerance symbology, and basic fabrication, construction, or architectural symbology.

ENABLING OBJECTIVES

- 1.1 **STATE** the purpose of engineering fabrication, construction, and architectural drawings.
- 1.2 Given an engineering fabrication, construction, or architectural drawing, **DETERMINE** the specified dimensions of an object.
- 1.3 Given an engineering fabrication, construction, or architectural drawing, **DETERMINE** the maximum and minimum dimensions or location of an object or feature from the stated drawing tolerance.

Intentionally Left Blank.

ENGINEERING FABRICATION, CONSTRUCTION, AND ARCHITECTURAL DRAWINGS

This chapter describes the basic symbology used in the dimensions and tolerances of engineering fabrication, construction, and architectural drawings. Knowledge of this information will make these types of prints easier to read and understand.

- EO 1.1** **STATE the purpose of engineering fabrication, construction, and architectural drawings.**
- EO 1.2** **Given an engineering fabrication, construction, or architectural drawing, DETERMINE the specified dimensions of an object.**
- EO 1.3** **Given an engineering fabrication, construction, or architectural drawing, DETERMINE the maximum and minimum dimensions or location of an object or feature from the stated drawing tolerance.**
-

Introduction

This chapter will describe engineering fabrication, construction, and architectural drawings. These three types of drawings represent the category of drawings commonly referred to as blueprints. Fabrication, construction, and architectural drawings differ from P&IDs, electrical prints, and logic diagrams in that they are drawn to scale and provide the component's physical dimensions so that the part, component, or structure can be manufactured or assembled. Although fabrication and construction drawings are presented as separate categories, both supply information about the manufacture or assembly of a component or structure. The only real difference between the two is the subject matter. A fabrication drawing provides information on how a single part is machined or fabricated in a machine shop, whereas a construction drawing provides the construction or assembly of large multi-component structures or systems.

Fabrication drawings, also called machine drawings, are principally found in and around machine and fabrication shops where the actual machine work is performed. The drawing usually depicts the part or component as an orthographic projection (see module 1 for definition) with each view containing the necessary dimensions. Figure 1 is an example of a fabrication drawing. In this case, the drawing is a centering rest that is used to support material as it is being machined.

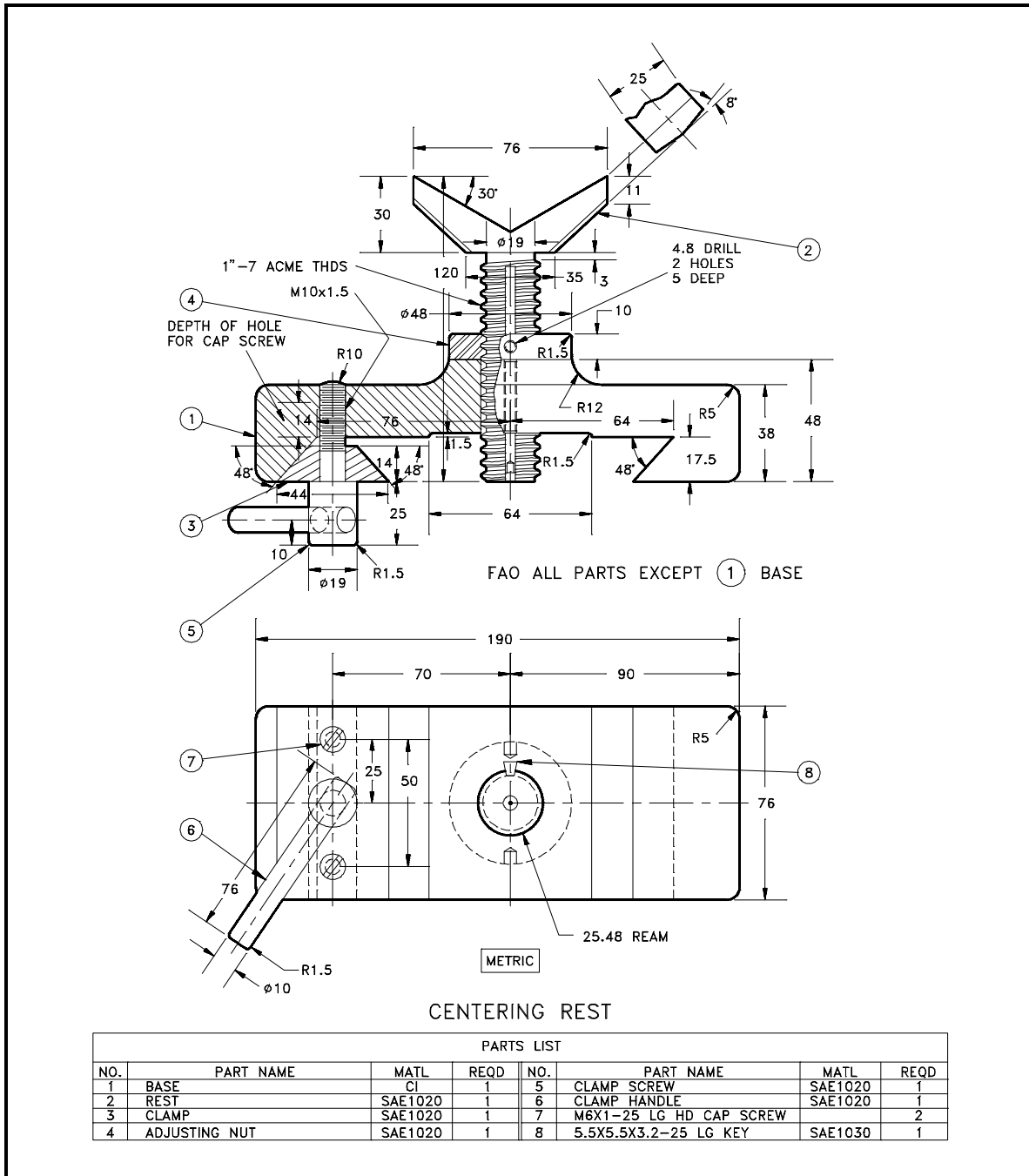

Figure 1 Example of a Fabrication Drawing

Construction drawings are found principally at sites where the construction of a structure or system is being performed. These drawings usually depict each structure/system or portion of a structure/system as an orthographic projection with each view containing the necessary dimensions required for assembly. Figure 2 provides an example of a construction print for a section of a steel roof truss.

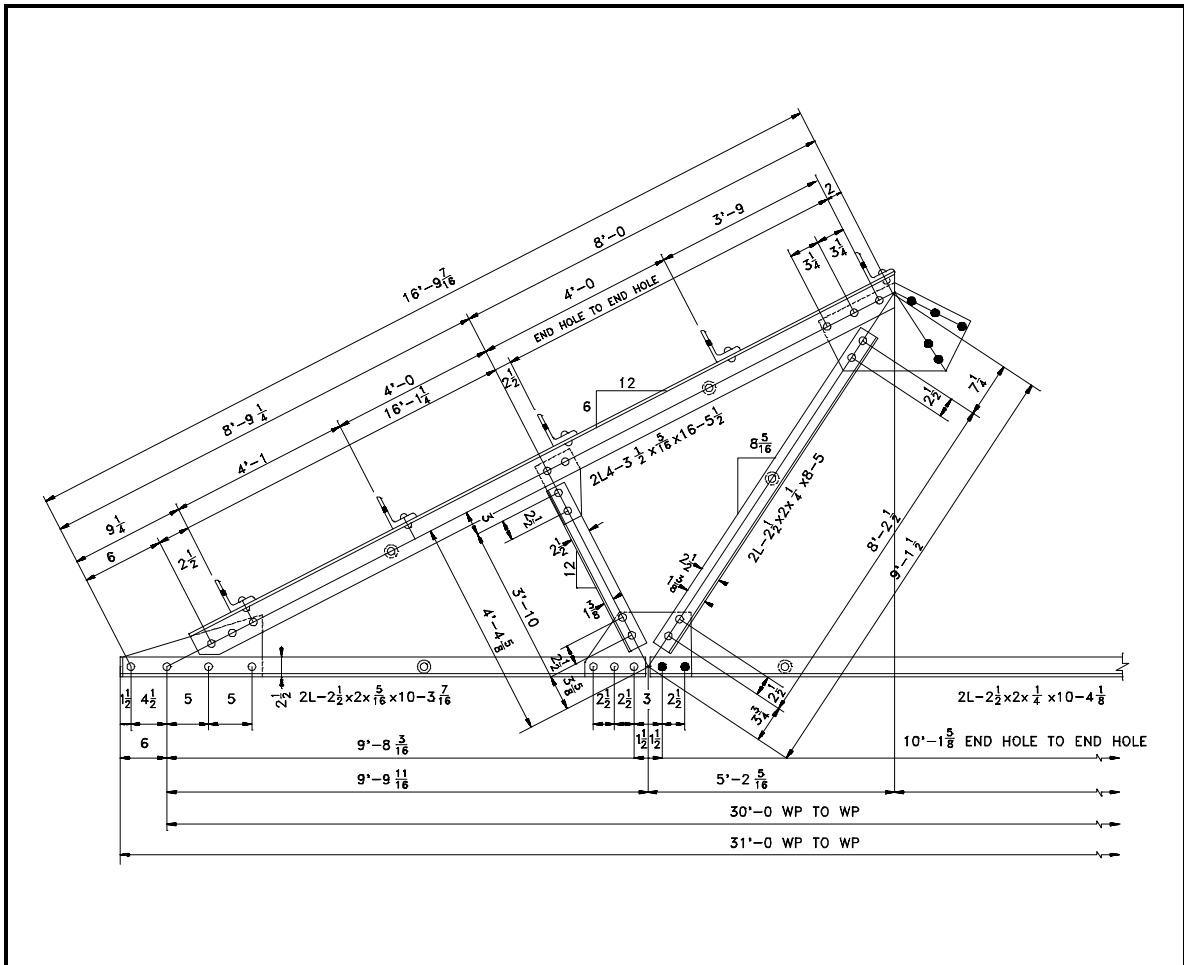

Figure 2 Example of a Construction Drawing

Architectural drawings are used by architects in the conceptual design of buildings and structures. These drawings do not provide detailed information on how the structure or building is to be built, but rather they provide information on how the designer wants the building to appear and how it will function. Examples of this are location-size-type of doors, windows, rooms, flow of people, storage areas, and location of equipment. These drawings can be presented in several formats, including orthographic, isometric, plan, elevation, or perspective. Figure 3 provides an example of an architectural drawing, of a county library.

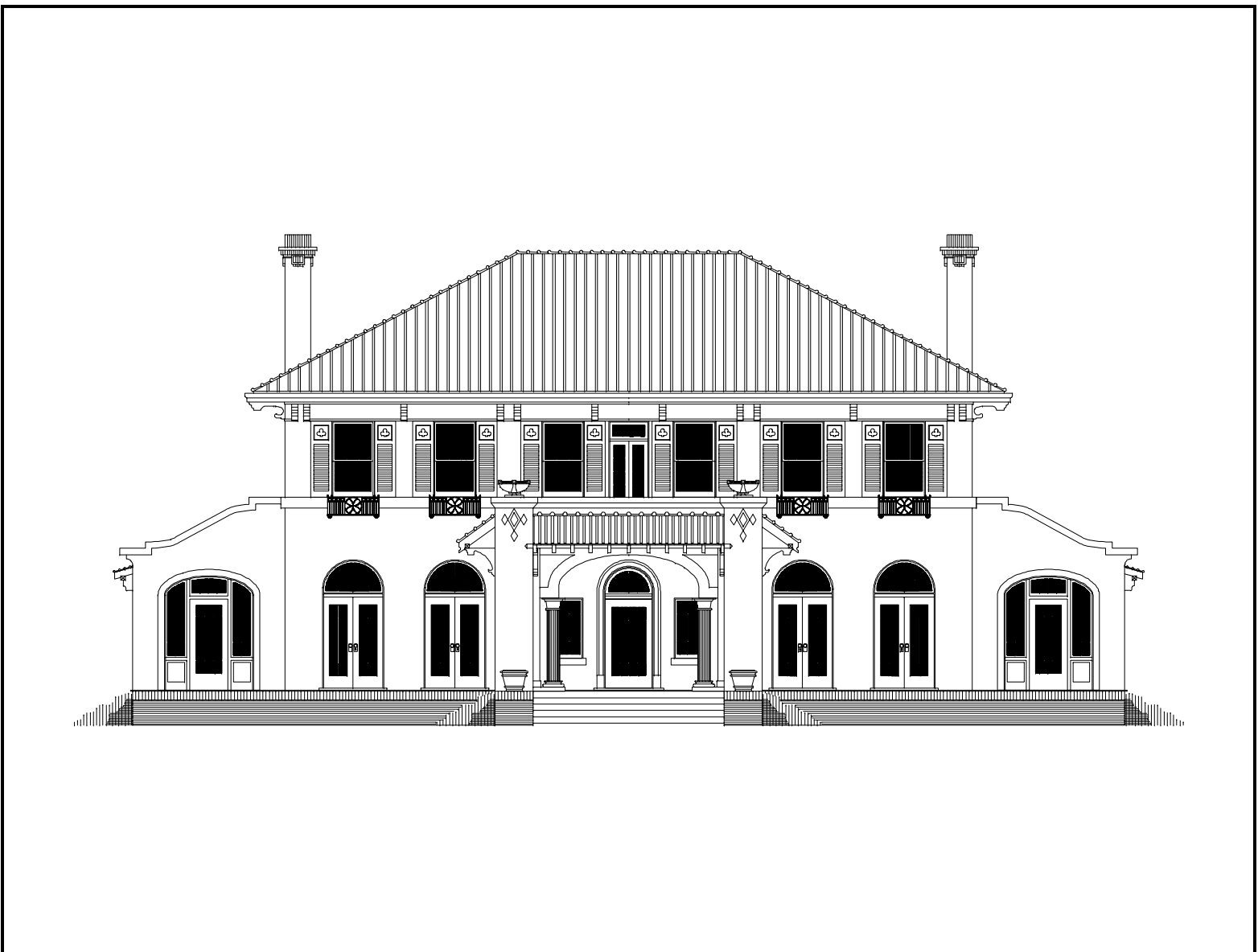

Figure 3 Example of an Architectural Drawing

Dimensioning Drawings

For any engineering fabrication, construction, or architectural drawing to be of value, exact information concerning the various dimensions and their tolerances must be provided by the drawing. Drawings usually denote dimensions and tolerances per the American National Standards Institute (ANSI) standards. These standards are explained in detail in Dimensioning and Tolerancing, ANSI Y14.5M - 1982. This section will review the basic methods of denoting dimensions and tolerances on drawings per the ANSI standards.

Dimensions on a drawing can be expressed in one of two ways. In the first method, the drawing is drafted to scale and any measurement is obtained by measuring the drawing and correcting for the scale. In the second method, the actual dimensions of the component are specified on the drawing. The second method is the preferred method because it reduces the chances of error and allows greater accuracy and drawing flexibility. Because even the simplest component has several dimensions that must be stated (and each dimension must have a tolerance), a drawing can quickly become cluttered with dimensions. To reduce this problem, the ANSI standards provide rules and conventions for dimensioning a drawing. The basic rules and conventions must be understood before a dimensioned drawing can be correctly read.

Dimensioning and Tolerance Symbology, Rules, and Conventions

When actual dimensions are specified on a print, the basic line symbols that are illustrated by Figure 4 are used.

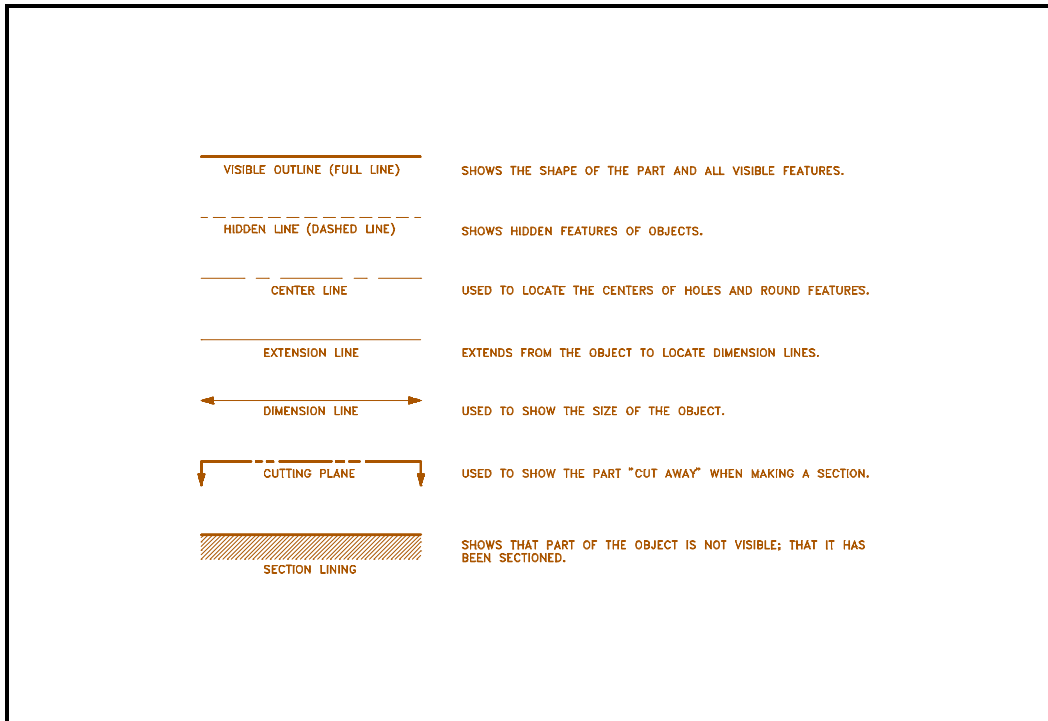

Figure 4 Types of Dimensioning Lines

Figure 5 provides examples of the various methods used on drawings to indicate linear, circular and angular dimensions.

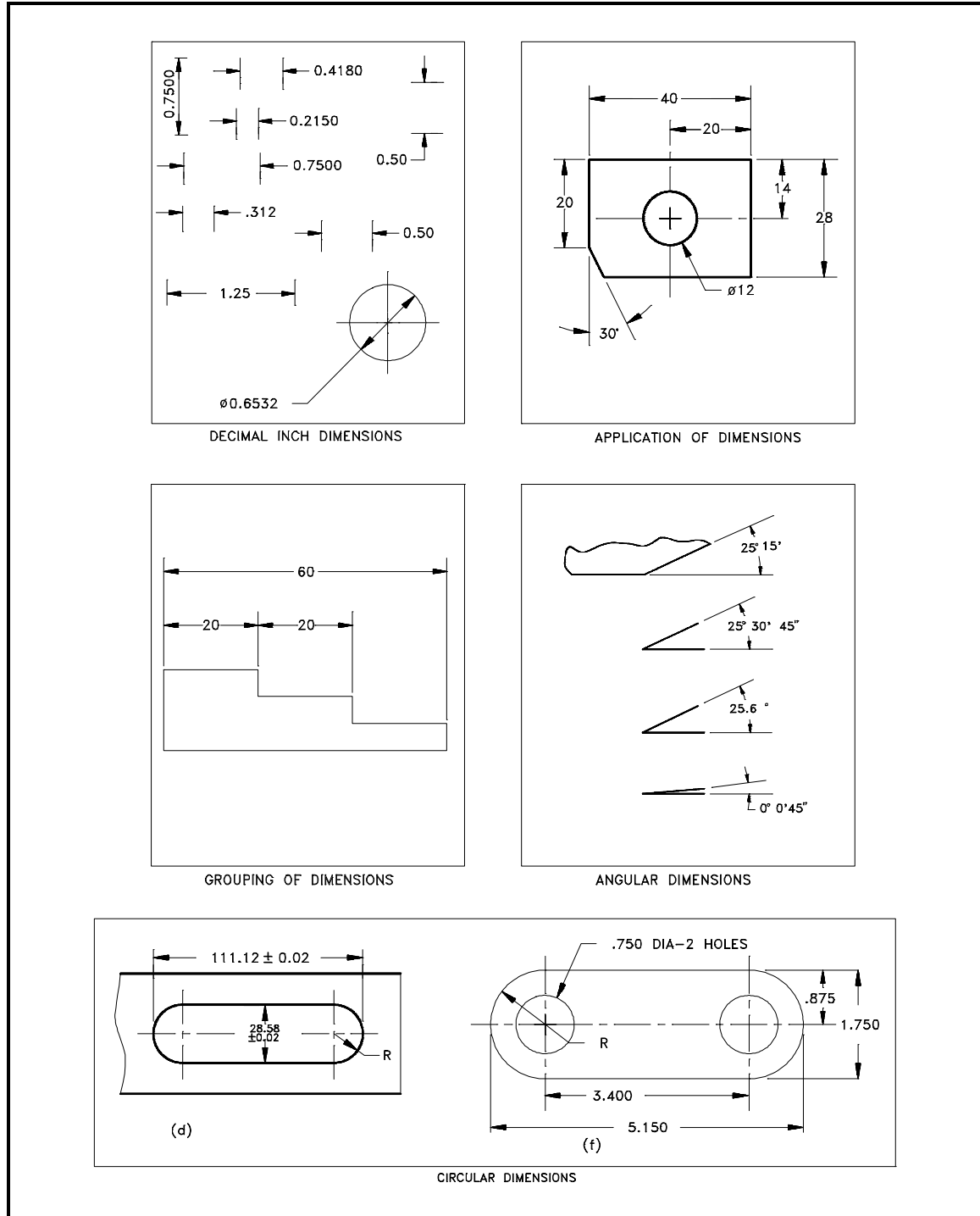

Figure 5 Example of Dimensioning Notation

When a drawing is dimensioned, each dimension must have a tolerance. In many cases, the tolerance is not stated, but is set to an implied standard. An example is the blueprint for a house. The measurements are not usually given stated tolerances, but it is implied that the carpenter will build the building to the normal tolerances of his trade (1/8-1/4 inch), and the design and use of the blueprints allow for this kind of error. Another method of expressing tolerances on a drawing is to state in the title block, or in a note, a global tolerance for all measurements on the drawing.

The last method is to state the tolerance for a specified dimension with the measurement. This method is usually used in conjunction with one of the other two tolerancing methods. This type of notation is commonly used for a dimension that requires a higher level of accuracy than the remainder of the drawing. Figure 6 provides several examples of how this type of tolerancing notation can appear on a drawing.

Tolerances are applied to more than just linear dimensions, such as 1 ± 0.1 inches. They can apply to any dimension, including the radius, the degree of out-of-round, the allowable out-of-square, the surface condition, or any other parameter that effects the shape and size of the object. These types of tolerances are called geometric tolerances. Geometric tolerances state the maximum allowable variation of a form or its position from the perfect geometry implied on the drawing. The term geometry refers to various forms, such as a plane, a cylinder, a cone, a square, or a hexagon. Theoretically these are perfect forms, but because it is impossible to produce perfect forms, it may be necessary to specify the amount of variation permitted. These tolerances specify either the diameter or the width of a tolerance zone within which a surface or the axis of a cylinder or a hole must be if the part is to meet the required accuracy for proper function and fit. The methods of indicating geometric tolerances by means of geometric characteristic symbols are shown in Figure 6. Examples of tolerance symbology are shown in Figure 7.

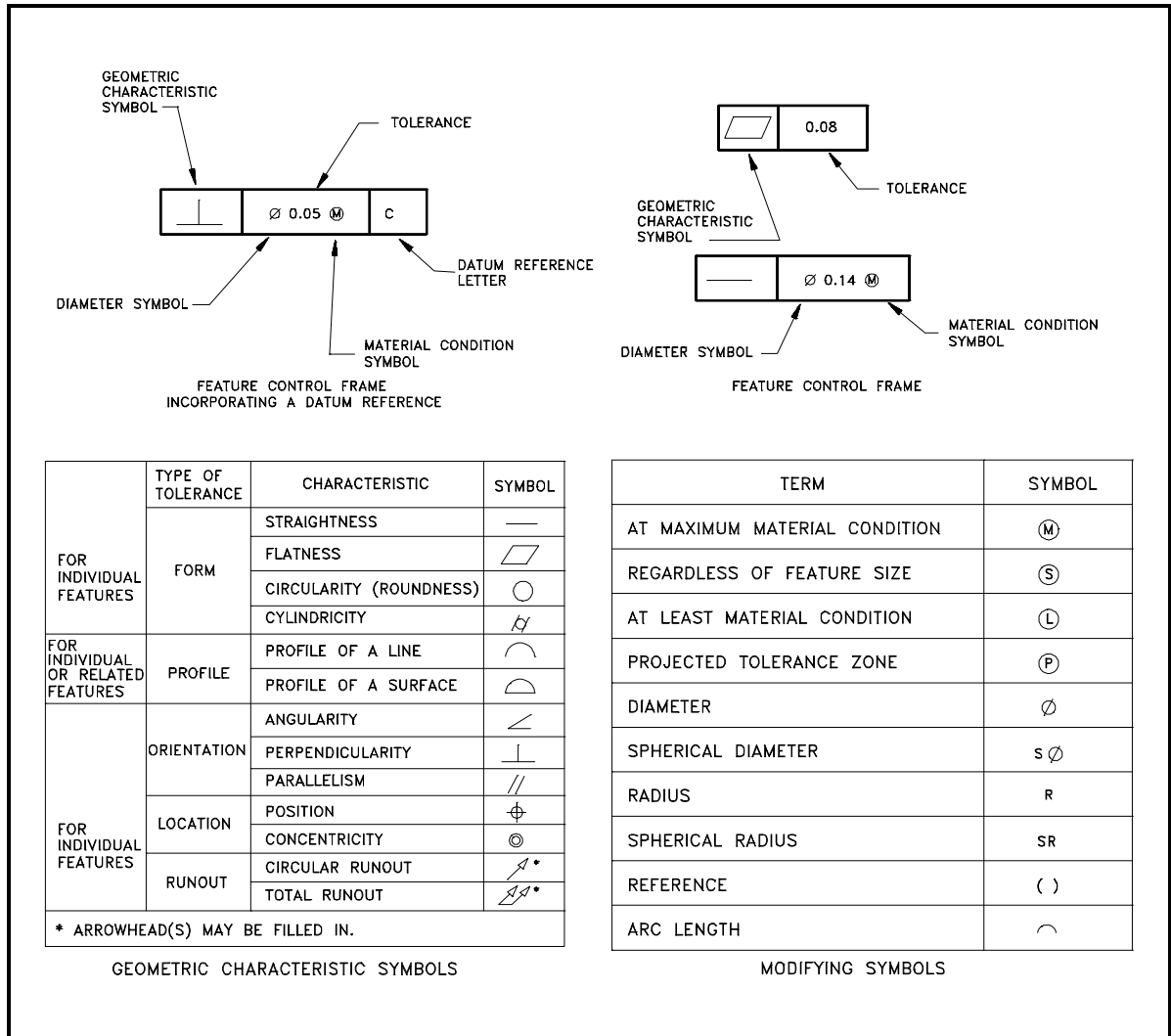

Figure 6 Symboly Used in Tolerancing Drawings

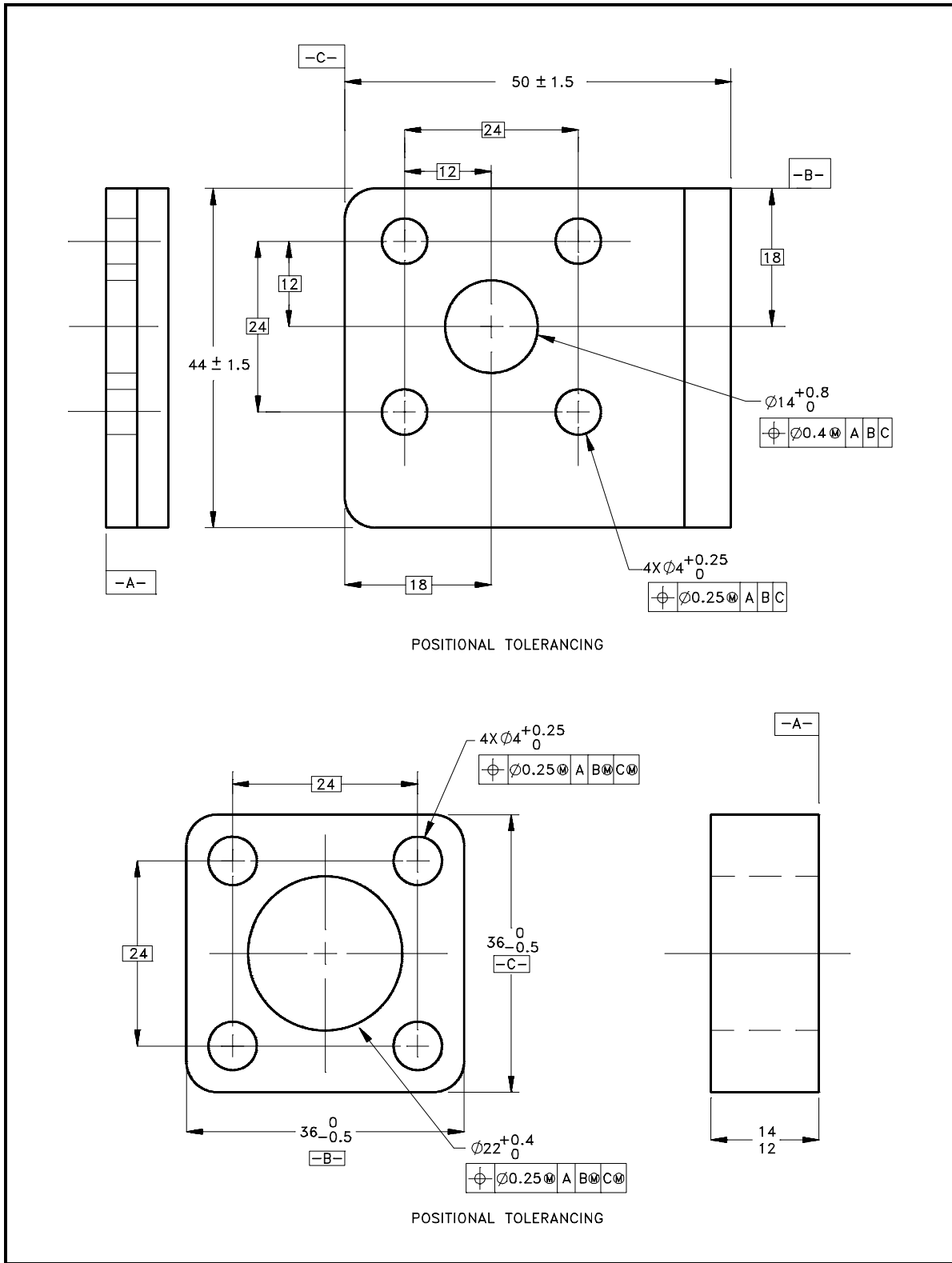

Figure 7 Examples of Tolerance Symboly

Because tolerances allow a part or the placement of a part or feature to vary or have a range, all of an object's dimensions can not be specified. This allows the unspecified, and therefor non-toleranced, dimension to absorb the errors in the critical dimensions. As illustrated in Figure 8 (A) for example, all of the internal dimensions plus each dimension's maximum tolerance adds up to more than the specified overall dimension and its maximum tolerance. In this case the length of each step plus its maximum tolerance is $1 \frac{1}{10}$ inches, for a maximum object length of $3 \frac{3}{10}$ inches. However the drawing also specifies that the total length of the object cannot exceed $3 \frac{1}{10}$ inches. A drawing dimensioned in this manner is not correct, and one of the following changes must be made if the part is to be correctly manufactured.

To prevent this type of conflict, the designer must either specify different tolerances for each of the dimensions so that the length of each smaller dimension plus its maximum error adds up to a value within the overall dimension plus its tolerance, or leave one of the dimensions off, as illustrated in Figure 8 (B) (the preferred method).

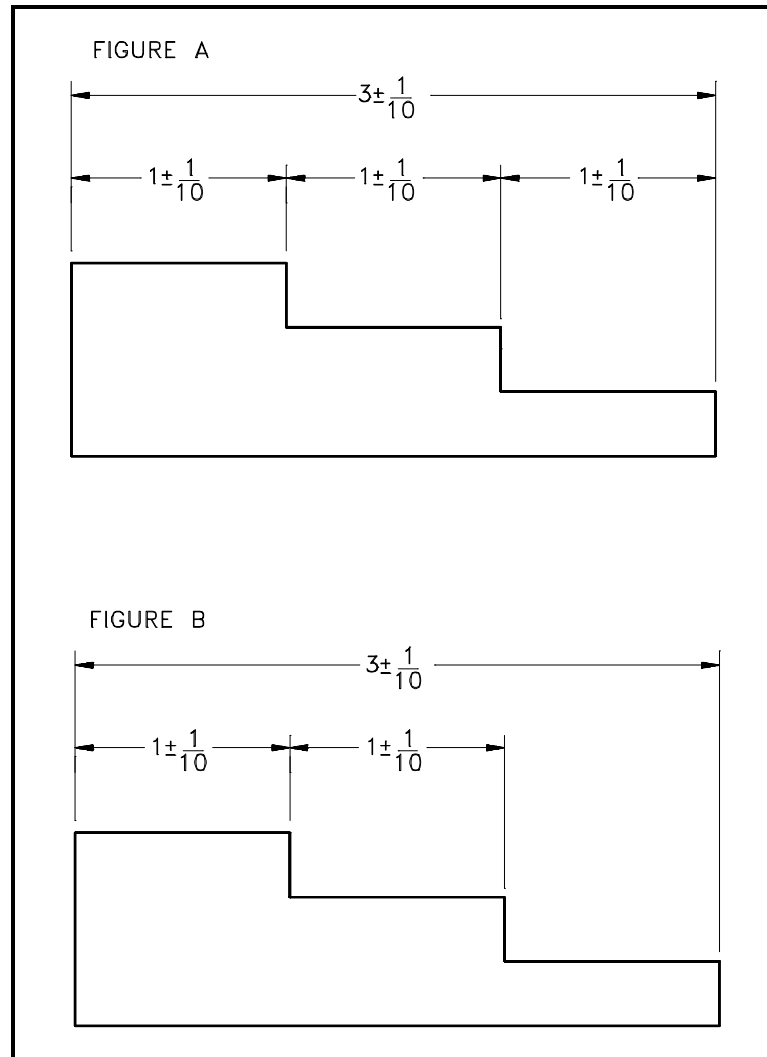

Figure 8 Example of Tolerancing

Summary

The important information in this chapter is summarized below.

Engineering Fabrication, Construction, and Architectural Drawings Summary

- The purpose of a fabrication drawing is to provide the information necessary to manufacture and machine components.
- The purpose of construction drawings is to provide the information necessary to build and assemble structures and systems.
- The purpose of architectural drawings is to provide conceptual information about buildings and structures.
- This chapter reviewed the basic symbology used in dimensioning engineering fabrication, construction, and architectural drawings.

ENGINEERING FABRICATION, CONSTRUCTION, AND ARCHITECTURAL DRAWING, EXAMPLES

The information presented in the previous chapter is reviewed in this chapter through the performance of reading drawing examples.

Examples

To aid in understanding the material presented in this module, practice reading the following prints by answering the questions. The answers are on the page following the last example.

Example 1

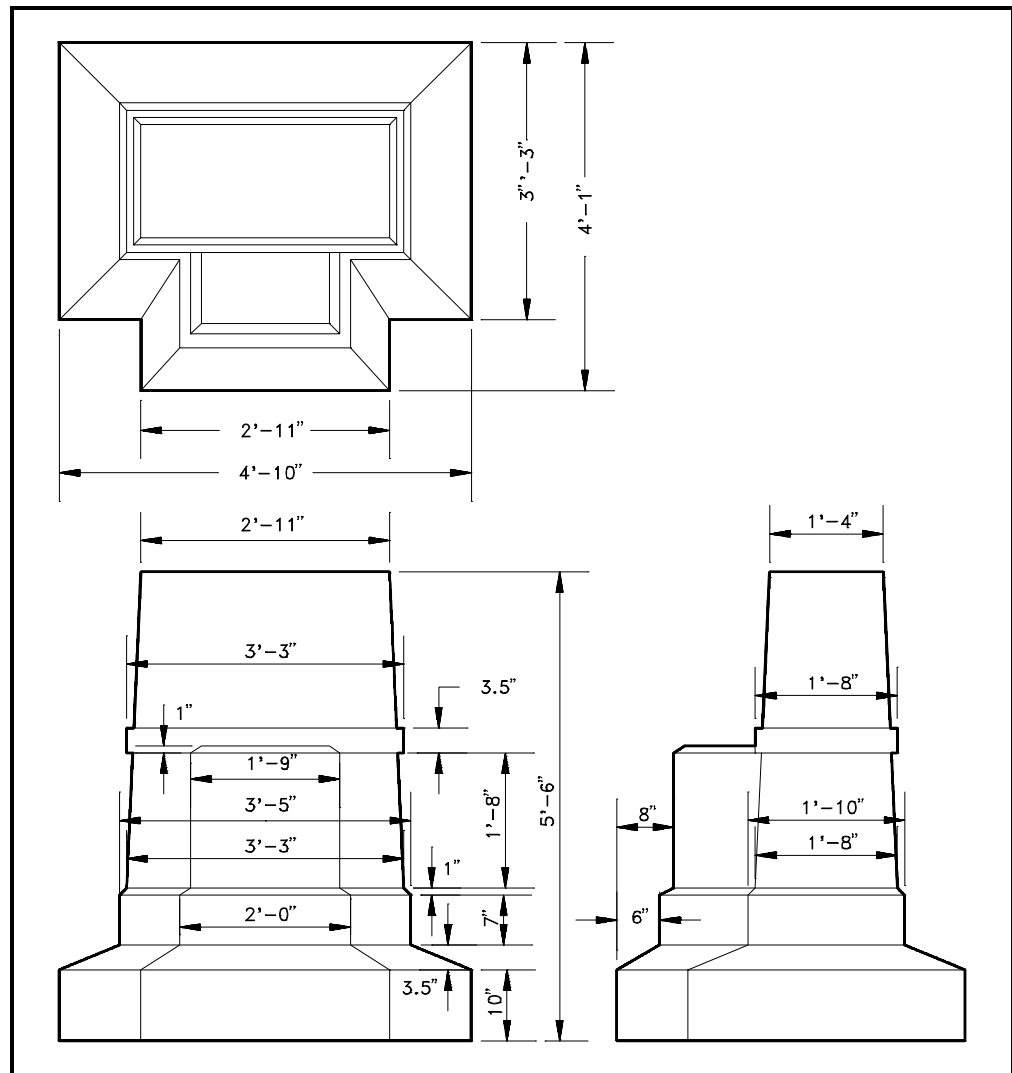

Figure 9 Example 1

1. What is the overall height of the structure?
2. What is the width (front-to-back) of the structure?
3. What is the difference between the width (front-to-back) and the width (side-to-side) of the base of the structure?

Example 2

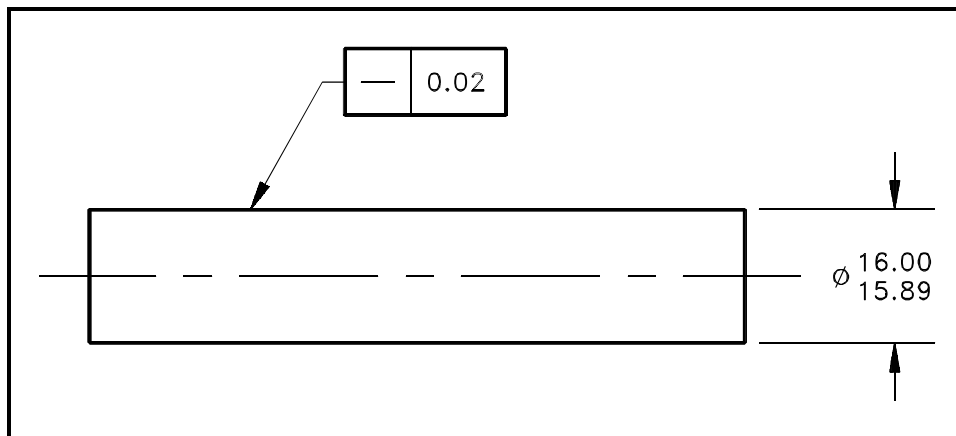

Figure 10 Example 2

1. What is the geometric characteristic being given a tolerance?
2. What is the maximum diameter of the shaft?
3. What is the minimum diameter of the shaft?

Example 3

Figure 11 Example 3

1. What is the geometric characteristic being given a tolerance?
2. What is the maximum length of the cylinder?
3. What is the minimum length of the cylinder?

Answers to example 1.

1. 5' 6"
2. 4' 1"
3. 9" (4' 10" side-to-side distance - 4' 1" front-to-back distance)

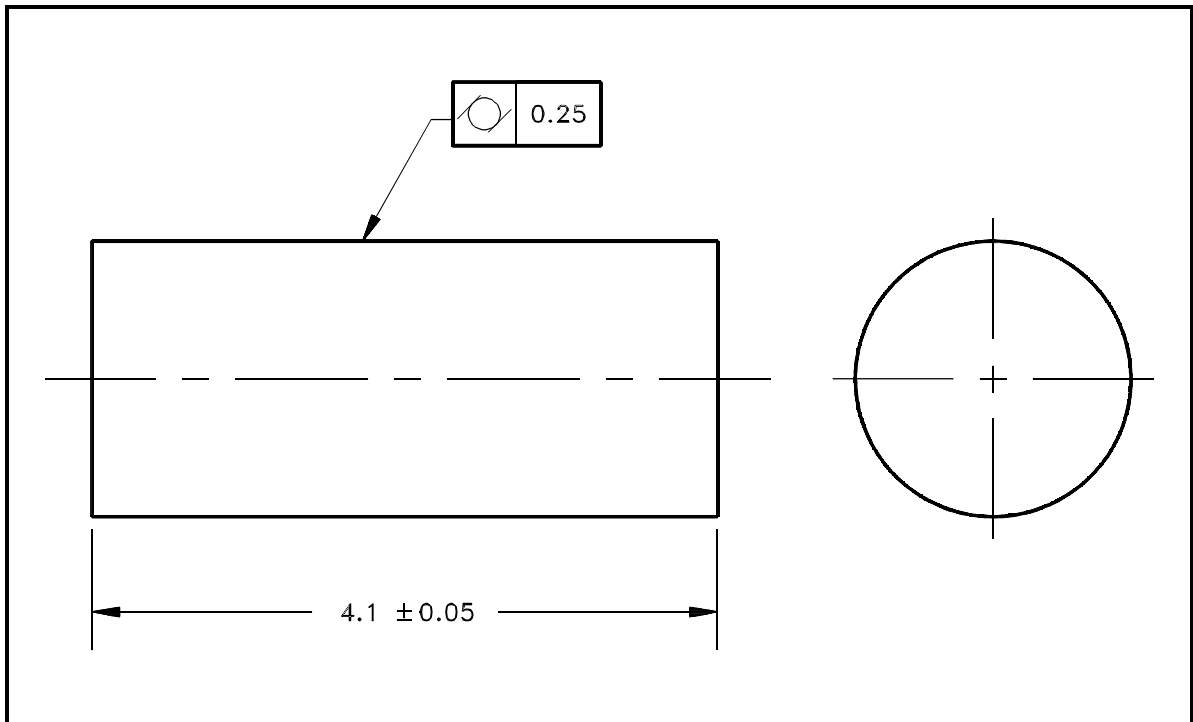
Answers to example 2.

1. Using Figure 6, the straight line in the geometric characteristic box indicates "straightness." This implies that the surface must be straight to within 0.02 inches.
2. 16.00 inches
3. 15.89 inches

Answers to example 3.

1. Using Figure 6, the circle with two parallel bars in the geometric characteristic box indicates "Cylindricity," or how close to being a perfect cylinder it must be (in this case 0.25 inches).
2. 4.15 inches. The nominal length of 4.1 plus the tolerance of 0.05.
3. 4.05 inches. The nominal length of 4.1 minus the tolerance of 0.05.

Summary

The important information in this chapter is summarized below.

**Engineering Fabrication, Construction,
and Architectural Drawing Exercise Summary**

- This chapter reviewed the material on dimensioning and tolerancing engineering fabrication, construction, and architectural drawings.

end of text.

CONCLUDING MATERIAL

Review activities:

DOE - ANL-W, BNL, EG&G Idaho,
EG&G Mound, EG&G Rocky Flats,
LLNL, LANL, MMES, ORAU, REEC_o,
WHC, WINCO, WEMCO, and WSRC.

Preparing activity:

DOE - NE-73
Project Number 6910-0022