



ROTARY DISTRIBUTOR DIESEL FUEL INJECTION PUMP

Stanadyne, Inc.
Diesel Systems Division
Windsor, Connecticut
April, 1988

National Historic Engineering Landmark



HISTORY

The year was 1947. The place was Hartford, Connecticut. Diesel power was about to make an historic move forward.

At that time, the world of high-speed diesel power in the U.S. was very limited. Less than 5 percent of all engines being built, even for non-automotive applications, were diesels.

Diesel power had proven to have real advantages. But for many applications, the price

was prohibitive. A small or medium-size high-speed diesel engine simply cost too much compared to its gasoline counterpart.

The high cost problem centered around the diesel fuel injection systems available at the time. A simpler, less expensive form of fuel injection was needed before diesels could compete effectively in the small or medium-size high-speed engine field.

The answer came from a man who had learned about diesel engines the hard way – by installing and maintaining diesel-electric generator sets in New York

City. His name was Vernon Roosa. And he brought his answer to Stanadyne's Hartford Division.

Roosa threw aside the traditional in-line injection pump with its pumping element for each engine cylinder. Instead, he used a single pumping unit to feed *all* the cylinders. Thus, the new pump had the same number of parts regardless of the number of cylinders.

Roosa then combined

this simple pumping system with the concept on inlet metering. This made the pump almost self-governing and meant that the actual governor could be a simple, low cost mechanism, further reducing the cost and complexity of the pump.

The result was a revolutionary new design – the first single cylinder, opposed plunger, inlet metering rotary distributor-type diesel fuel injection pump.

It was the smallest, simplest fuel injection pump the world had ever seen, at a much lower price than anything available before.

It opened up a new world for builders and users of diesel engines – a world that has been expanding ever since.

Simplicity Made It Practical – Success did not come overnight for the Roosa Master pump. The industry was full of skeptics who said it could never be produced commercially. Five years of testing and development work were required before a single sale was made. Then, in March 1952 came the first production order. Hercules Motors Corporation wanted pumps for Oliver Cletrac tractors.

Continental Motors followed Hercules as a customer in 1953. Buda Engine Company, which later became part of Allis Chalmers, came next, and by 1956 Waukesha engines were utilizing the rotary distributor pump.

Throughout this period, Roosa Master engineers were busy working on making the pump even simpler, more versatile and less expensive.

Work began on the Roosa Master fuel injection pump in May, 1947. From 1947 to 1952, activities were concentrated on laboratory developments and experimental installations. During 1952, production of the Model "A" pump was begun. This model remained in production through 1955.

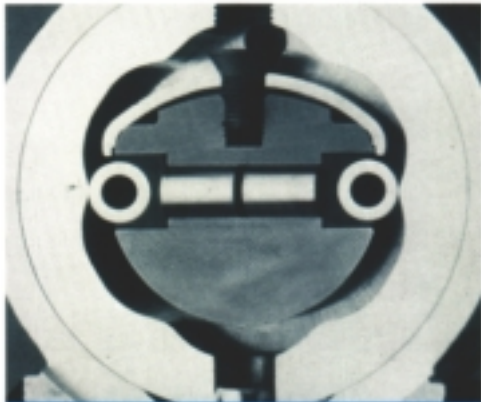

Rotary Distribution Principle



The rotary distribution pump played a key role in the rapid growth of diesel usage in farm tractors.

The period between 1955 and 1958 was a development stage during which Model "B" and Model "D" pumps were introduced. Model "B", with sand cast housing was the forerunner of Model "D" of the die cast construction, and Model "D" was replaced by the Model "DB" which began production in 1958.

In general, the object of the Model "DB" was standardization. It incorporated all the basic features of its forerunners, the Model "A", Model "B", and Model "D", into one standard housing with built-in pluses. Accessories such as automatic

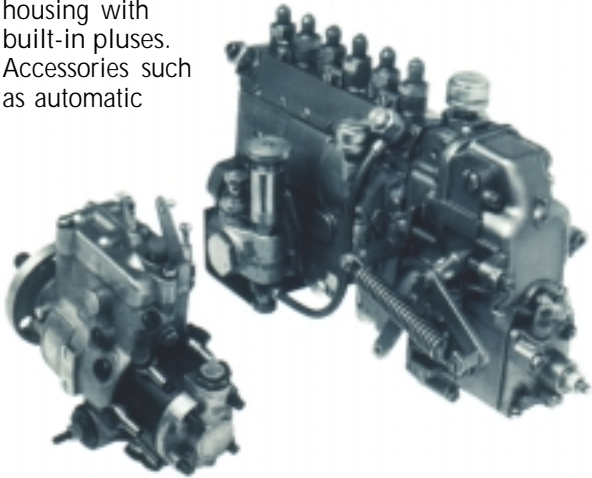

Size comparison of distribution type pump (left) to traditional in-line pump.

advance and electric shut-off could be built right into the DB housing. A single delivery valve was located in the center of the rotor, providing improved part load regularity.

Due to the inherent design of the DB pump, cost-effective timing advance systems extended the diesel's speed, and hence, power range to further encroach on gasoline engine use. In addition, the pump generally offered improved governor performance, which was particularly attractive to diesel engine builders.

Most importantly, the Model DB pump could be mounted either horizontally or vertically. Because of the pump's lower driving torque, it could be driven off smaller gears than other types of fuel injection pumps. This meant that the pump could be mounted vertically in the location normally used for the ignition distributor on a gasoline engine block.

This versatility was destined to save engine manufacturers thousands of dollars by allowing them to use the same basic block for both gasoline and diesel engines.

It paved the way for farm equipment manufacturers, who were already making their

own gasoline engines, to get into the production of diesel engines with a minimum of tooling costs. This move was to have a dramatic impact on the growth of high-speed diesels in the country.

Today, over 90% of the farm and industrial tractors produced in this country are diesel powered. But back in the mid 1950s, the reverse was true.

The switch to diesel power on the farm gained momentum in the late 1950s when farm equipment manufacturers began offering diesel tractors priced competitively with their gasoline powered equivalents. Farm equipment manufacturers were able to do this because they had started producing their own high-speed diesel engines. They were able to manufacture these engines for little more than their gasoline counterparts, thanks in large measure to the savings achieved by using rotary distributor fuel injection pumps.

Soon, Allis Chalmers, Ford, International Harvester, John Deere, J.I. Case, and Minneapolis Moline became pump users. By 1961, practically every diesel farm tractor built in this country was equipped with a Roosa Master pump.

The first generation of diesel engines built by these manufacturers were basically modified gasoline engine blocks to minimize the tooling costs associated with entering a new field. New generations of diesel engines were soon to follow.

Farmers were finally able to enjoy all the advantages of diesel power for a very small premium. And take advantage they did! The high-speed diesel engine was on its way to becoming an important factor in American life.

Diesel engine builders were not the only companies interested in the new design. The introduction of the pump also had a major impact on manufacturers of traditional in-line fuel injection equipment throughout the world. The prospect of having a license for manufacture of the rotary distributor pump was obviously very desirable if these manufacturers were to compete in the smaller, high-speed engine field.

On May 1, 1953, an agreement was signed granting CAV Ltd., of London, England the rights to manufacture and market pumps of the Roosa Master design for the United Kingdom, with further expansion to other parts of the world in subsequent agreements.

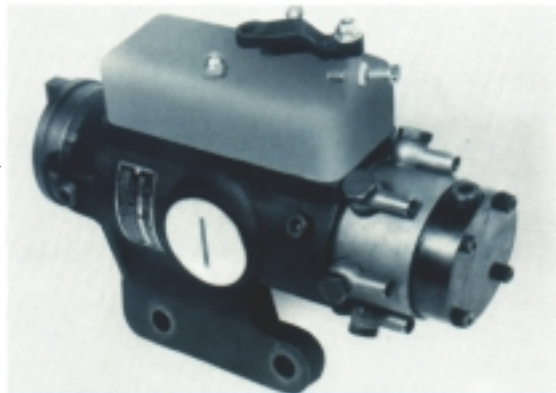

Early RoosaMaster pump configuration

TECHNICAL BACKGROUND

General Description – An external view of a typical pump is shown in Fig. 1 and an internal section in Fig. 2.

The main rotating components are the drive shaft (1), distributor rotor (2), transfer pump blades (5), and governor components (11).

The drive shaft engages the distributor rotor in the hydraulic head. The drive end of the rotor incorporates two pumping plungers.

The plungers are actuated toward each other simultaneously by an internal cam ring through rollers and shoes which are carried in slots at the drive end of the rotor. The number of cam lobes normally equals the number of engine cylinders.

The transfer pump at the rear of the rotor is the positive displacement vane-type and is enclosed in the end cap. The end cap also houses the fuel inlet strainer and transfer pump pressure regulator. Transfer pump pressure is automatically compensated for viscosity effects due to both temperature changes and various fuel grades.

The distributor rotor incorporates two charging ports and a single axial bore with one discharge port to serve all head outlets to the injection tubings. The hydraulic head contains the bore in which the rotor revolves, the metering valve bore, the charging ports and the head outlet fittings. The high pressure injection tubings leading to the nozzles are fastened to these fittings.

Distributor pumps contain their own mechanical governor capable of close speed regulation. Both all-speed and min-max types are available. The centrifugal force of the weights in their retainer is transmitted through a sleeve to the governor arm and through a linkage to the metering valve. The metering valve can be closed to shut off fuel through the linkage by an independently operated shut-off lever.



Fig. 1 — Pump

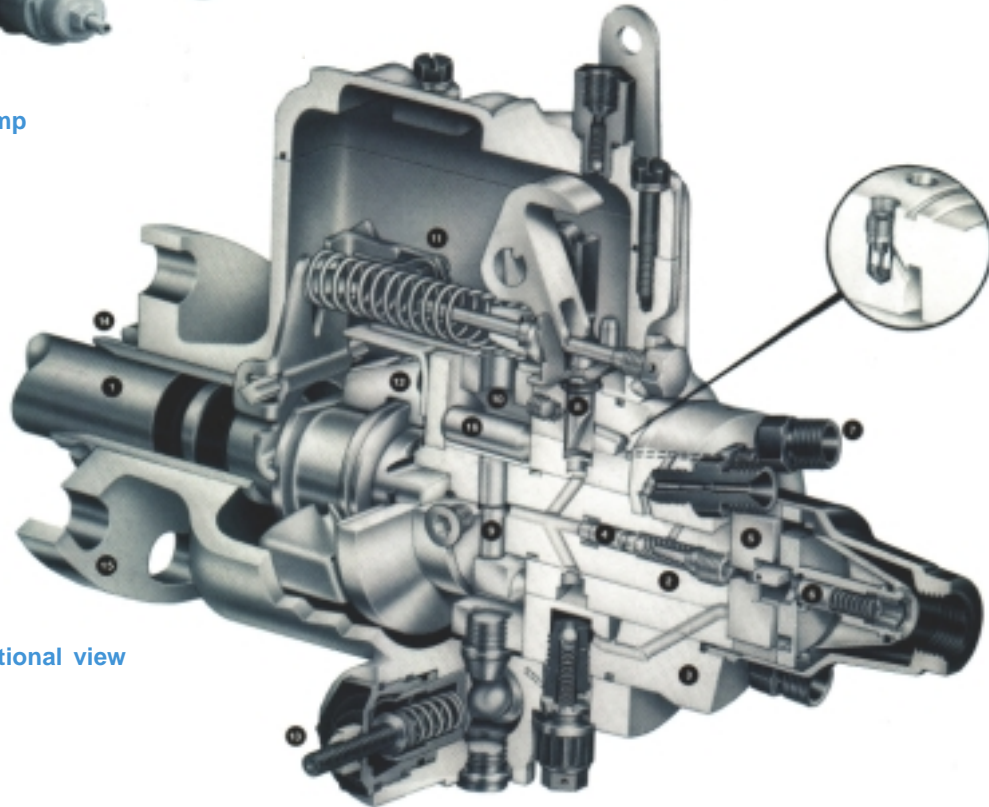

Fig. 2 — Sectional view

Components:

1. Drive Shaft
2. Distributor Rotor
3. Hydraulic Head
4. Delivery Valve
5. Transfer Pump
6. Pressure Regulator
7. Discharge Fitting
8. Metering Valve
9. Pumping Plungers
10. Internal Cam Ring
11. Governor
12. Governor Weights
13. Advance
14. Drive Shaft Bushing
15. Housing
16. Rollers

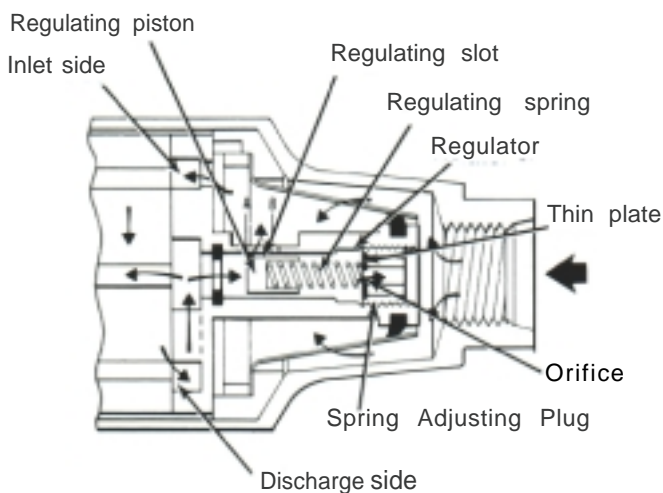

Fig. 3 — Transfer pump regulator

The automatic speed advance is a hydraulic mechanism which advances or retards the beginning of fuel delivery from the pump. This can respond to speed alone, or to a combination of speed and load changes. A more detailed description of each pump area will be covered in the following pages.

Transfer pump pressure regulation – Refer to Fig. 3 for the following description. Filtered, low pressure fuel from an overhead tank or a lift pump passes through the transfer pump inlet screen. This vane-type pump consists of a stationary liner and four spring loaded blades, which are carried in the rotor slots. Excess fuel is recirculated to the transfer pump inlet by means of the pressure regulator piston, spring, and ported sleeve. Fuel pressure from the transfer pump forces the piston in the regulator sleeve against the spring. The pressure curve is controlled by the pump displacement, spring rate and preload, and regulating slot configuration. Therefore, pressure increases with speed.

The transfer pump operates consistently over a wide viscosity range determined by different grades of diesel fuels and also when affected by varying temperatures. A thin plate incorporating a sharp-edged orifice is located in the spring adjusting plug. Flow through an orifice of this type is virtually unaffected by viscosity changes. An additional biasing pressure is exerted against the spring side of the piston and is determined by the linear flow around the regulating piston and the flow through the orifice. With cold or viscous fuels a reduced flow occurs through the piston and sleeve

clearance, and the additional biasing pressure is slight. With hot or low viscosity fuels the clearance flow increases and the pressure within the spring chamber increases. The regulating spring and higher biasing pressure forces combine to control the slot area. This control maintains a nearly constant transfer pump pressure over a broad range of fuel viscosities and thus maintains stable automatic advance operation over various fuel types and temperatures.

Hydraulic head and rotor – Fig. 4 shows an exploded view of the rotor and the pumping plungers. The cam rollers contact the inner surface of the cam ring form and push the plungers toward each other for injection. The shoes act as tappets between the rollers and plungers.

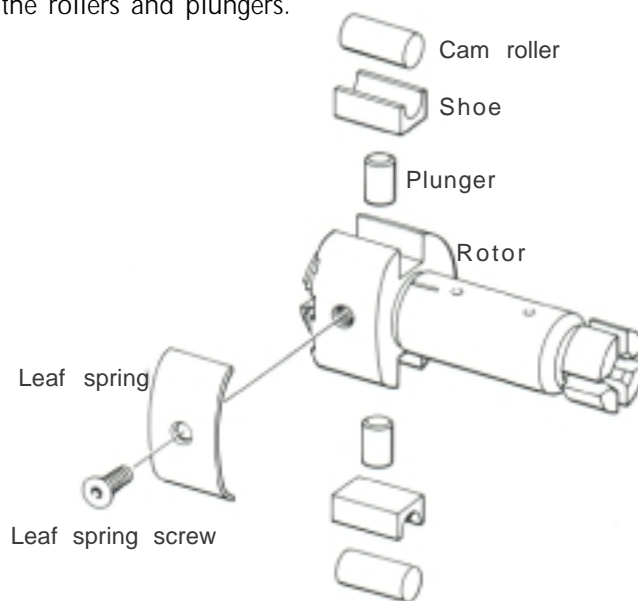

Fig. 4 — Rotor and plunger

Refer to Fig. 5. As the rotor revolves, its two inlet passages register with the charging annulus ports in the hydraulic head. Transfer pump fuel controlled by the metering valve opening, flows into the pumping chamber forcing the plungers apart. The plungers move outward for a distance proportional to the amount of fuel required for the next injection stroke. If only a small amount is admitted, as at idling, the plungers move out a short distance. If half-load is required, approximately half the pumping chamber is filled. This process is known as inlet metering.

Full-load delivery is controlled by the maximum plunger travel. This plunger travel is limited by the leaf spring as it is contacted by the edge of the shoes.

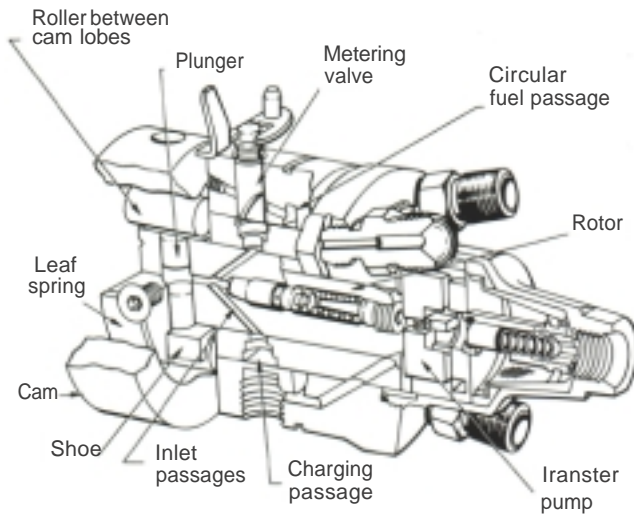

Fig. 5 — Plunger charging

Refer to Fig. 6. The leaf spring contacts two points near the outer ends of the rotor. As the adjusting screw is turned inward, the center of the leaf spring moves in and its ends extend outward. This increases the maximum plunger travel. Turning the adjusting screw out has the reverse effect. The adjustment set point is retained by the screw head-to-leaf spring

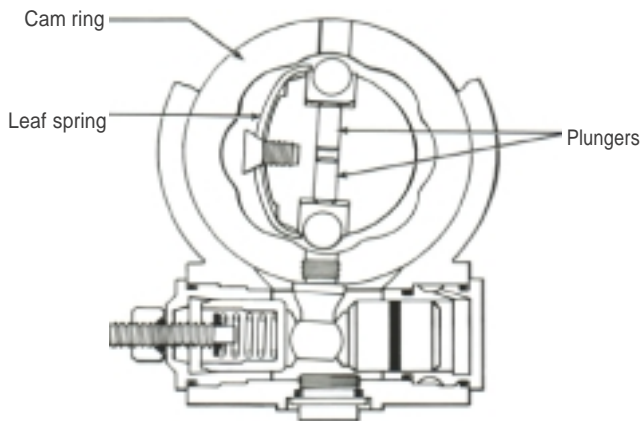

Fig. 6 — Cam, plungers and leaf spring

friction and the coating material on the screw threads.

As the rotor continues to revolve (Fig. 7), the inlet ports move out of registry and the rotor discharge port indexes with one of the head outlets. The rollers then contact opposing cam lobes which force the shoes inward against the plungers. At this point high pressure pumping begins. Further rotation of the rotor moves the

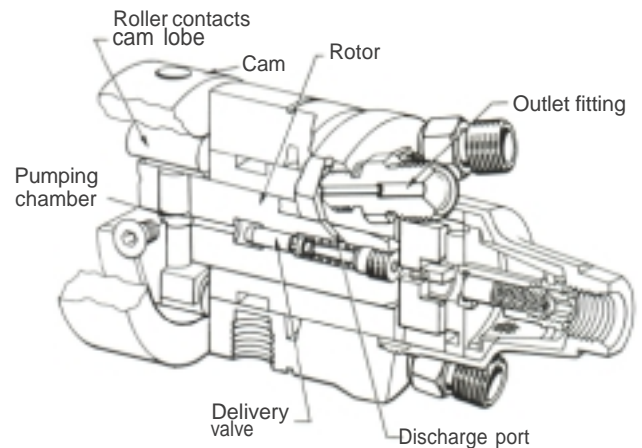

Fig. 7 — Plunger discharging

rollers along the cam ramps forcing the plungers together. During the discharge stroke the fuel between the plungers is displaced into the axial passage of the rotor through the delivery valve to the discharge port. The pressurized fuel then passes through the outlet fitting, enters the injection tubing and opens the nozzle. Delivery continues until the rollers travel over the cam noses and begin to move outwardly. The pressure in the axial passage is then reduced, allowing the nozzle to close.

VERNON D. ROOSA

Vernon D. Roosa

Born on a farm in New York state, Vernon Roosa came naturally to his inventive turn of mind. His father, who raised Holstein cattle, devised a hydraulic dam to raise the water level, constructed a windmill and had one of the first milking machines.

Fascinated by mechanics as a youngster, Roosa had to leave school at age 15 because of the family's financial reverses. His first job as a gas attendant led to his becoming the station manager within a year. He left to attend an aviation engineering school. During the Depression, as a mechanic with a large bus company, he first became interested in diesel engines and finally landed a job installing and maintaining a diesel power plant.

He subsequently went to work for a Long Island firm making diesel electric generator sets for New York apartments. In the fall of 1939, to fill the need for a variable speed and output generator, he concentrated on making a fuel injection pump that would meet the stringent requirements of this application and a year later had one in operation. About this time, the armed services were seeking a new method for close speed regulation of generator sets. Roosa produced a second design, simpler and extremely small in size compared to other makes, with a self-contained plunger completely sealed against dirt, water and oil leakage.

This is the model that caught the eye of Stanadyne's Hartford Division, in 1947. Roosa came to Hartford that year and embarked on a five year program to perfect his miraculous pump, and later a fuel injection nozzle and filter design which became widely used. He also designed an automatic drill machine, required for the nozzle assembly.

Vernon worked closely and was respected by all major engine manufacturers worldwide. In 1986 he received the SAE Edward N. Cole engineering award.

After 22 years at Stanadyne nurturing his brainchild through numerous improvements and developing accessories, Roosa retired as vice-president of research and development to devote his time to independent inventing, although he remained a consultant to the company.

His inventions have ranged far beyond diesel engine pumps. He holds 350 patents, both United States and foreign, which fill three thick volumes. Among them are a stapler, a butane lighter for outdoor fireplaces, a novel toilet flush system, a nail polish remover bottle with a brush, a gas tank filler and numerous electrical switching devices.



Vernon D. Roosa

The inventor has a keen interest in higher education. He donated a chair in applied science to Trinity College, where he once taught as an adjunct professor, and in 1984, pledged funds for a chair in manufacturing engineering at the University of Hartford's College of Engineering. In addition, to help train disabled workers, he invented a "hands free" head lantern for the Hartford Easter Seal Rehabilitation Center. The Center makes and sells the product to the government, forest fire fighters, and on the

commercial market. He also developed and donated the equipment for manufacturing the head lamp.

At 77, he is still active in the design of new products from a fully equipped laboratory in West Hartford, Connecticut.

**NATIONAL HISTORIC MECHANICAL
ENGINEERING LANDMARK
DISTRIBUTOR-TYPE DIESEL FUEL INJECTION PUMP
Hartford, Connecticut
1952**

Vernon D. Roosa invented the rotary distributor-type fuel injection pump in 1941. It provided a compact, low-cost fuel injection system for diesel engines up to 200 HP. The first production order for 500 Roosa Master Model A pumps was received in 1952, and approximately 23 million distributor pumps have been manufactured by Stanadyne and its licensees worldwide.

Vernon D. Roosa - Inventor
Ernest J. Willson - Development Engineer
Leonard N. Baxter - assisted in development
American Society of Mechanical Engineers
1988

ACKNOWLEDGEMENTS

The Hartford Section of the American Society of Mechanical Engineers gratefully acknowledges the efforts of all who cooperated in the dedication of the Distributor-Type Diesel Fuel Injection Pump as a National Historic Mechanical Engineering Landmark.

The American Society of Mechanical Engineers

Richard Rosenberg, President
Dr. Wellen G. Davison, Vice President, Region I
Donald W. Kitchin, Jr., History and Heritage,
Region I

ASME Hartford Section

Ray Schneider, Chairman

**The ASME National History
and Heritage Committee**

Dr. Euan F.C. Somerscales, Chairman
Robert M. Vogel, Smithsonian Institution
Dr. Robert B. Gaither
Dr. Richard S. Hartenberg
Dr. J. Paul Hartman
Joseph P. Van Overveen
Dr. R. Carson Dalzell, Chairman Emeritus
Carron Garvin-Donohue, Staff Liaison

Stanadyne, Inc.

Many dedicated Stanadyne employees played a key role in the development of the rotary distributor pump and its subsequent place in diesel engine history. Stanadyne thanks them all and would especially acknowledge the following people.

George J. Michel, Jr.
Gerald R. Bouwkamp
James A. Taylor (deceased)
Michael J. Perrin (deceased)
Augustus D. Rose
C. Eugene Brady
Paul H. Wabrek
James J. Ford
Thomas D. Hess
Vernon D. Roosa
Ernest J. Willson (deceased)
Leonard N. Baxter
Frank Link