

# MAN B&W G95ME-C9.5

IMO Tier II

Project Guide



Introduction



Contents

Engineering the Future – since 1758.

**MAN Diesel & Turbo**





# MAN B&W G95ME-C9.5-TII

## Project Guide

### Electronically Controlled Two-stroke Engines

This Project Guide is intended to provide the information necessary for the layout of a marine propulsion plant.

The information is to be considered as **preliminary**. It is intended for the project stage only and subject to modification in the interest of technical progress. The Project Guide provides the general technical data available at the date of issue.

It should be noted that all figures, values, measurements or information about performance stated in this project guide are **for guidance only** and should not be used for detailed design purposes or as a substitute for specific drawings and instructions prepared for such purposes.

#### Data updates

Data not finally calculated at the time of issue is marked 'Available on request'. Such data may be made available at a later date, however, for a specific project the data can be requested. Pages and table entries marked 'Not applicable' represent an option, function or selection which is not valid.

The latest, most current version of the individual Project Guide sections are available on the Internet at: [www.marine.man.eu](http://www.marine.man.eu) → 'Two-Stroke'.

#### Extent of Delivery

The final and binding design and outlines are to be supplied by our licensee, the engine maker, see Chapter 20 of this Project Guide.

In order to facilitate negotiations between the yard, the engine maker and the customer, a set of 'Extent of Delivery' forms is available in which the basic and the optional executions are specified.

#### Electronic versions

This Project Guide book and the 'Extent of Delivery' forms are available on the Internet at: [www.marine.man.eu](http://www.marine.man.eu) → 'Two-Stroke', where they can be downloaded.

Edition 0.5

April 2014



*All data provided in this document is non-binding. This data serves informational purposes only and is especially not guaranteed in any way.*

*Depending on the subsequent specific individual projects, the relevant data may be subject to changes and will be assessed and determined individually for each project. This will depend on the particular characteristics of each individual project, especially specific site and operational conditions.*

*If this document is delivered in another language than English and doubts arise concerning the translation, the English text shall prevail.*

**MAN Diesel & Turbo**  
Tegholmmsgade 41  
DK-2450 Copenhagen SV  
Denmark  
Telephone +45 33 85 11 00  
Telefax +45 33 85 10 30  
mandiesel-cph@mandiesel.com  
www.mandieselturbo.com

Copyright 2014 © MAN Diesel & Turbo, branch of MAN Diesel & Turbo SE, Germany, registered with the Danish Commerce and Companies Agency under CVR Nr.: 31611792, (herein referred to as "MAN Diesel & Turbo").

This document is the product and property of MAN Diesel & Turbo and is protected by applicable copyright laws. Subject to modification in the interest of technical progress. Reproduction permitted provided source is given.  
7020-0154-00ppr Apr 2014



## MAN B&W

---

### Introduction

Dear reader, this manual provides you with a number of convenient navigation features:

↔ Scroll through the manual page-by-page



Use this button to navigate to the chapter menu



Use this button to navigate back to this page (Introduction page)

#### See also:

- **MAN Diesel & Turbo website**
- **Marine Engine Programme 2014**
- **CEAS application**  
Calculates basic data essential for the design and dimensioning of a ship's engine room based on engine specification.
- **Turbocharger Selection application**  
Calculates available turbocharger(s) configuration based on engine specification.
- **DieselFacts**  
MAN Diesel & Turbo customer magazine with the news from the world's leading provider of large-bore diesel engines and turbomachinery for marine and stationary applications.
- **Installation drawings**  
Download installation drawings for low speed engines in DXF and PDF formats.
- **Technical papers**  
MAN Diesel & Turbo has a long tradition of producing technical papers on engine design and applications for licensees, shipyards and engine operators.



---

Engine Design .....	1
Engine Layout and Load Diagrams, SFOC .....	2
Turbocharger Selection & Exhaust Gas By-pass .....	3
Electricity Production .....	4
Installation Aspects .....	5
List of Capacities: Pumps, Coolers & Exhaust Gas .....	6
Fuel .....	7
Lubricating Oil .....	8
Cylinder Lubrication .....	9
Piston Rod Stuffing Box Drain Oil .....	10
Central Cooling Water System .....	11
Seawater Cooling System .....	12
Starting and Control Air .....	13
Scavenge Air .....	14
Exhaust Gas .....	15
Engine Control System .....	16
Vibration Aspects .....	17
Monitoring Systems and Instrumentation .....	18
Dispatch Pattern, Testing, Spares and Tools .....	19
Project Support and Documentation .....	20
Appendix .....	A

---



<b>Chapter</b>	<b>Section</b>	
<b>1 Engine Design</b>		
The fuel optimised ME Tier II engine	1.01	1988537-1.4
Tier II fuel optimisation	1.01	1990112-5.0
Engine type designation	1.02	1983824-3.9
Power, speed, SFOC	1.03	1989185-2.0
Engine power range and fuel oil consumption	1.04	1984634-3.5
Performance curves	1.05	1985331-6.2
ME Engine description	1.06	1988366-8.1
<b>2 Engine Layout and Load Diagrams, SFOC</b>		
Engine layout and load diagrams	2.01	1983833-8.5
Propeller diameter and pitch, influence on optimum propeller speed	2.02	1983878-2.6
Layout diagram sizes	2.03	1989228-5.0
Engine layout and load diagrams	2.04	1986993-5.3
Diagram for actual project	2.05	1989247-6.0
Specific fuel oil consumption, ME versus MC engines	2.06	1985310-1.0
SFOC for high efficiency turbochargers	2.07	1987017-7.4
SFOC reference conditions and guarantee	2.08	1988341-6.1
Examples of graphic calculation of SFOC	2.08	1988279-4.2
SFOC calculations (75%-88%)	2.09	1989273-8.0
SFOC calculations, example	2.10	1989321-8.0
Fuel consumption at an arbitrary load	2.11	1983843-4.5
<b>3 Turbocharger Selection &amp; Exhaust Gas Bypass</b>		
Turbocharger selection	3.01	1989513-6.0
Exhaust gas bypass	3.02	1985629-0.3
Emission control	3.03	1988447-2.2
<b>4 Electricity Production</b>		
Electricity production	4.01	1984155-0.5
Designation of PTO	4.01	1984286-7.6
PTO/RCF	4.01	1984300-0.3
Space requirements for side mounted PTO/RCF	4.02	1990050-1.0
Engine preparations for PTO	4.03	1984315-6.3
PTO/BW GCR	4.04	1984758-9.0
Waste Heat Recovery Systems (WHRS)	4.05	1985797-7.5
WHRS generator output	4.05	1989235-6.0
WHR element and safety valve	4.05	1988288-9.1
GenSet data	4.06-8	1984792-3.0
L27/38-TII GenSet data	4.09	1988284-1.0
L28/32H-TII GenSet data	4.10	1988285-3.0
L32/40-TII GenSet data	4.11	1988286-5.0



<b>Chapter</b>	<b>Section</b>	
<b>5 Installation Aspects</b>		
Space requirements and overhaul heights	5.01	1984375-4.7
Crane beam for overhaul of turbochargers	5.03	1990009-6.0
Crane beam for turbochargers	5.03	1984848-8.3
Engine room crane	5.04	1989168-5.0
Overhaul with Double-Jib crane	5.04	1984534-8.4
Double-Jib crane	5.04	1984541-9.2
Engine outline, galleries and pipe connections	5.05	1984715-8.3
Engine and gallery outline	5.06	1989173-2.0
Counterflanges, Connection D	5.10	1986670-0.6
Counterflanges, Connection E	5.10	1987027-3.4
Engine seating and holding down bolts	5.11	1984176-5.11
Engine seating profile	5.12	1989169-7.1
Engine top bracing	5.13	1984672-5.8
Hydraulic top bracing arrangement	5.15	1989170-7.0
Components for Engine Control System	5.16	1988538-3.2
Shaftline earthing device	5.17	1984929-2.4
MAN Alpha Controllable Pitch (CP) propeller	5.18	1986157-3.2
<b>6 List of Capacities: Pumps, Coolers &amp; Exhaust Gas</b>		
Calculation of capacities	6.01	1988291-2.0
List of capacities	6.03	1989354-2.0
Auxiliary system capacities for derated engines	6.04	1989259-6.0
Pump capacities, pressures and flow velocities	6.04	1986198-0.2
Example 1, Pumps and Cooler Capacity	6.04	1989393-6.0
Freshwater Generator	6.04	1987145-8.1
Example 2, Fresh Water Production	6.04	1989394-8.0
Calculation of exhaust gas amount and temperature	6.04	1984318-1.3
Diagram for change of exhaust gas amount	6.04	1989269-2.0
Exhaust gas correction formula	6.04	1987140-9.0
Example 3, Expected Exhaust Gas	6.04	1989396-1.0
<b>7 Fuel</b>		
Pressurised fuel oil system	7.01	1984228-2.7
Fuel oil system	7.01	1987660-9.3
Fuel oils	7.02	1983880-4.7
Fuel oil pipes and drain pipes	7.03	1989113-4.0
Fuel oil pipe insulation	7.04	1984051-8.3
Fuel oil pipe heat tracing	7.04	1986768-4.2
Components for fuel oil system	7.05	1983951-2.8
Components for fuel oil system, venting box	7.05	1984735-0.3
Water in fuel emulsification	7.06	1983882-8.5





<b>Chapter</b>	<b>Section</b>	
<b>8 Lubricating Oil</b>		
Lubricating and cooling oil system	8.01	1984230-4.5
Hydraulic Power Supply unit	8.02	1984231-6.3
Hydraulic Power Supply unit and lubricating oil pipes	8.02	1988348-9.1
Lubricating oil pipes for turbochargers	8.03	1984232-8.5
Lubricating oil consumption, centrifuges and list of lubricating oils	8.04	1983886-5.10
Flushing of lubricating oil components and piping system	8.05	1988026-6.0
Lubricating oil outlet	8.05	1987034-4.1
Lubricating oil tank	8.06	1989172-0.0
Crankcase venting and bedplate drain pipes	8.07	1984259-3.5
Engine and tank venting to the outside air	8.07	1989182-7.0
Hydraulic oil back-flushing	8.08	1984829-7.3
Separate system for hydraulic control unit	8.09	1984852-3.5
<b>9 Cylinder Lubrication</b>		
Cylinder lubricating oil system	9.01	1988559-8.2
List of cylinder oils	9.01	1988566-9.1
MAN B&W Alpha cylinder lubrication system	9.02	1983889-0.10
Alpha Adaptive Cylinder Oil Control (Alpha ACC)	9.02	1987614-4.1
Cylinder oil pipe heating	9.02	1987612-0.1
Cylinder lubricating oil pipes	9.02	1985520-9.5
Small heating box with filter, suggestion for	9.02	1987937-9.1
<b>10 Piston Rod Stuffing Box Drain Oil</b>		
Stuffing box drain oil system	10.01	1988345-3.0
<b>11 Central Cooling Water System</b>		
Central cooling	11.01	1984696-5.5
Central cooling water system	11.02	1984057-9.5
Components for central cooling water system	11.03	1983987-2.6
<b>12 Seawater Cooling</b>		
Seawater systems	12.01	1983892-4.4
Seawater cooling system	12.02	1983893-6.5
Cooling water pipes	12.03	1988305-8.1
Components for seawater cooling system	12.04	1983981-1.3
Jacket cooling water pipes	12.06	1990220-3.0
Components for jacket cooling water system	12.07	1984056-7.3
Deaerating tank	12.07	1984061-4.3
Temperature at start of engine	12.08	1983986-0.3
<b>13 Starting and Control Air</b>		
Starting and control air systems	13.01	1983995-5.3
Components for starting air system	13.02	1986057-8.1
Starting and control air pipes	13.03	1984000-4.7





<b>Chapter</b>	<b>Section</b>	
<b>14 Scavenge Air</b>		
Scavenge air system	14.01	1984002-8.5
Auxiliary blowers	14.02	1988547-8.0
Control of the auxiliary blowers	14.02	1988556-2.0
Scavenge air pipes	14.03	1984013-6.5
Electric motor for auxiliary blower	14.04	1990203-6.0
Scavenge air cooler cleaning system	14.05	1987684-9.1
Air cooler cleaning unit	14.05	1989229-7.0
Scavenge air box drain system	14.06	1989161-2.0
Fire extinguishing system for scavenge air space	14.07	1990148-5.0
<b>15 Exhaust Gas</b>		
Exhaust gas system	15.01	1984047-2.7
Exhaust gas pipes	15.02	1984070-9.4
Cleaning systems, water	15.02	1984071-0.8
Soft blast cleaning systems	15.02	1984072-2.4
Exhaust gas system for main engine	15.03	1984074-6.3
Components of the exhaust gas system	15.04	1984075-8.7
Calculation of exhaust gas back-pressure	15.05	1984094-9.3
Forces and moments at turbocharger	15.06	1990051-3.0
Diameter of exhaust gas pipe	15.07	1984098-6.2
<b>16 Engine Control System</b>		
Engine Control System ME	16.01	1984847-6.9
Engine Control System layout	16.01	1987923-5.2
Mechanical-hydraulic system with HPS	16.01	1987924-7.2
Engine Control System interface to surrounding systems	16.01	1988531-0.2
Pneumatic manoeuvring diagram	16.01	1987926-0.1
<b>17 Vibration Aspects</b>		
Vibration aspects	17.01	1984140-5.3
2nd order moments on 5 and 6-cylinder engines	17.02	1988361-9.0
Electrically driven moment compensator	17.03	1984222-1.6
Guide force moments	17.05	1984223-3.5
Guide force moments, data	17.05	1984517-1.1
Vibration limits valid for single order harmonics	17.05	1988264-9.0
Axial vibrations	17.06	1984224-5.4
Critical running	17.06	1984226-9.3



<b>Chapter</b>	<b>Section</b>	
<b>18 Monitoring Systems and Instrumentation</b>		
Monitoring systems and instrumentation	18.01	1988529-9.2
PMI Auto-tuning system	18.02	1988530-9.2
CoCoS-EDS systems	18.03	1984582-6.8
Alarm - slow down and shut down system	18.04	1987040-3.4
Class and MAN Diesel & Turbo requirements	18.04	1984583-8.10
Local instruments	18.05	1984586-3.9
Other alarm functions	18.06	1984587-5.13
Bearing monitoring systems	18.06	1986726-5.5
LDCL cooling water monitoring system	18.06	1990197-5.0
Control devices	18.06	1986728-9.4
Identification of instruments	18.07	1984585-1.6
<b>19 Dispatch Pattern, Testing, Spares and Tools</b>		
Dispatch pattern, testing, spares and tools	19.01	1987620-3.2
Specification for painting of main engine	19.02	1984516-9.6
Dispatch pattern	19.03	1987632-3.2
Shop test	19.05	1984612-7.8
List of spare parts, unrestricted service	19.06	1986416-2.10
Additional spares	19.07	1984636-7.9
Wearing parts	19.08	1984637-9.6
List of standard tools for maintenance	19.10	1990106-6.0
<b>20 Project Support and Documentation</b>		
Project support and documentation	20.01	1984588-7.5
Installation data application	20.02	1984590-9.3
Extent of Delivery	20.03	1984591-0.6
Installation documentation	20.04	1984592-2.5
<b>A Appendix</b>		
Symbols for piping	A	1983866-2.3



**MAN B&W**

---

---

# Engine Design

1

---

---

**MAN Diesel**



## The Fuel Optimised ME Tier II Engine

The ever valid requirement of ship operators is to obtain the lowest total operational costs, and especially the lowest possible specific fuel oil consumption at any load, and under the prevailing operating conditions.

However, low-speed two-stroke main engines of the MC-C type, with a chain driven camshaft, have limited flexibility with regard to fuel injection and exhaust valve activation, which are the two most important factors in adjusting the engine to match the prevailing operating conditions.

A system with electronically controlled hydraulic activation provides the required flexibility, and such systems form the core of the ME Engine Control System, described later in detail in Chapter 16.

### Concept of the ME engine

The ME engine concept consists of a hydraulic-mechanical system for activation of the fuel injection and the exhaust valves. The actuators are electronically controlled by a number of control units forming the complete Engine Control System.

MAN Diesel & Turbo has specifically developed both the hardware and the software in-house, in order to obtain an integrated solution for the Engine Control System.

The fuel pressure booster consists of a simple plunger powered by a hydraulic piston activated by oil pressure. The oil pressure is controlled by an electronically controlled proportional valve.

The exhaust valve is opened hydraulically by means of a two-stage exhaust valve actuator activated by the control oil from an electronically controlled proportional valve. The exhaust valves are closed by the 'air spring'.

In the hydraulic system, the normal lube oil is used as the medium. It is filtered and pressurised by a Hydraulic Power Supply unit mounted on the engine or placed in the engine room.

The starting valves are opened pneumatically by electronically controlled 'On/Off' valves, which make it possible to dispense with the mechanically activated starting air distributor.

By electronic control of the above valves according to the measured instantaneous crankshaft position, the Engine Control System fully controls the combustion process.

System flexibility is obtained by means of different 'Engine running modes', which are selected either automatically, depending on the operating conditions, or manually by the operator to meet specific goals. The basic running mode is 'Fuel economy mode' to comply with IMO NO<sub>x</sub> emission limitation.

### Engine design and IMO regulation compliance

The ME-C engine is the shorter, more compact version of the ME engine. It is well suited wherever a small engine room is requested, for instance in container vessels.

For MAN B&W ME/ME-C-TII designated engines, the design and performance parameters comply with the International Maritime Organisation (IMO) Tier II emission regulations.

For engines built to comply with IMO Tier I emission regulations, please refer to the Marine Engine IMO Tier I Project Guide.

**Tier II fuel optimisation**

NO<sub>x</sub> regulations place a limit on the SFOC on two-stroke engines. In general, NO<sub>x</sub> emissions will increase if SFOC is decreased and vice versa. In the standard configuration, MAN B&W engines are optimised close to the IMO NO<sub>x</sub> limit and, therefore, NO<sub>x</sub> emissions may not be further increased.

The IMO NO<sub>x</sub> limit is given as a weighted average of the NO<sub>x</sub> emission at 25, 50, 75 and 100% load. This relationship can be utilised to tilt the SFOC profile over the load range. This means that SFOC can be reduced at part load or low load at the expense of a higher SFOC in the high-load range without exceeding the IMO NO<sub>x</sub> limit.

Optimisation of SFOC in the part-load (50-85%) or low-load (25-70%) range requires selection of a tuning method:

- ECT: Engine Control Tuning
- VT: Variable Turbine Area
- EGB: Exhaust Gas Bypass
- HPT: High Pressure Tuning (only for ME-C)

Each tuning method makes it possible to optimise the fuel consumption when normally operating at low loads, while maintaining the possibility of operating at high load when needed.

The tuning methods are available for all SMCR in the specific engine layout diagram but they cannot be combined. The specific SFOC reduction potential of each tuning method together with full rated ( $L_1/L_3$ ) and maximum derated ( $L_2/L_4$ ) is shown in Section 1.03.

For engine types 40 and smaller, as well as for larger types with conventional turbochargers, only high-load optimisation is applicable.

In general, data in this project guide is based on high-load optimisation unless explicitly noted. For part- and low-load optimisation, calculations can be made in the CEAS application described in Section 20.02.



### Engine Type Designation

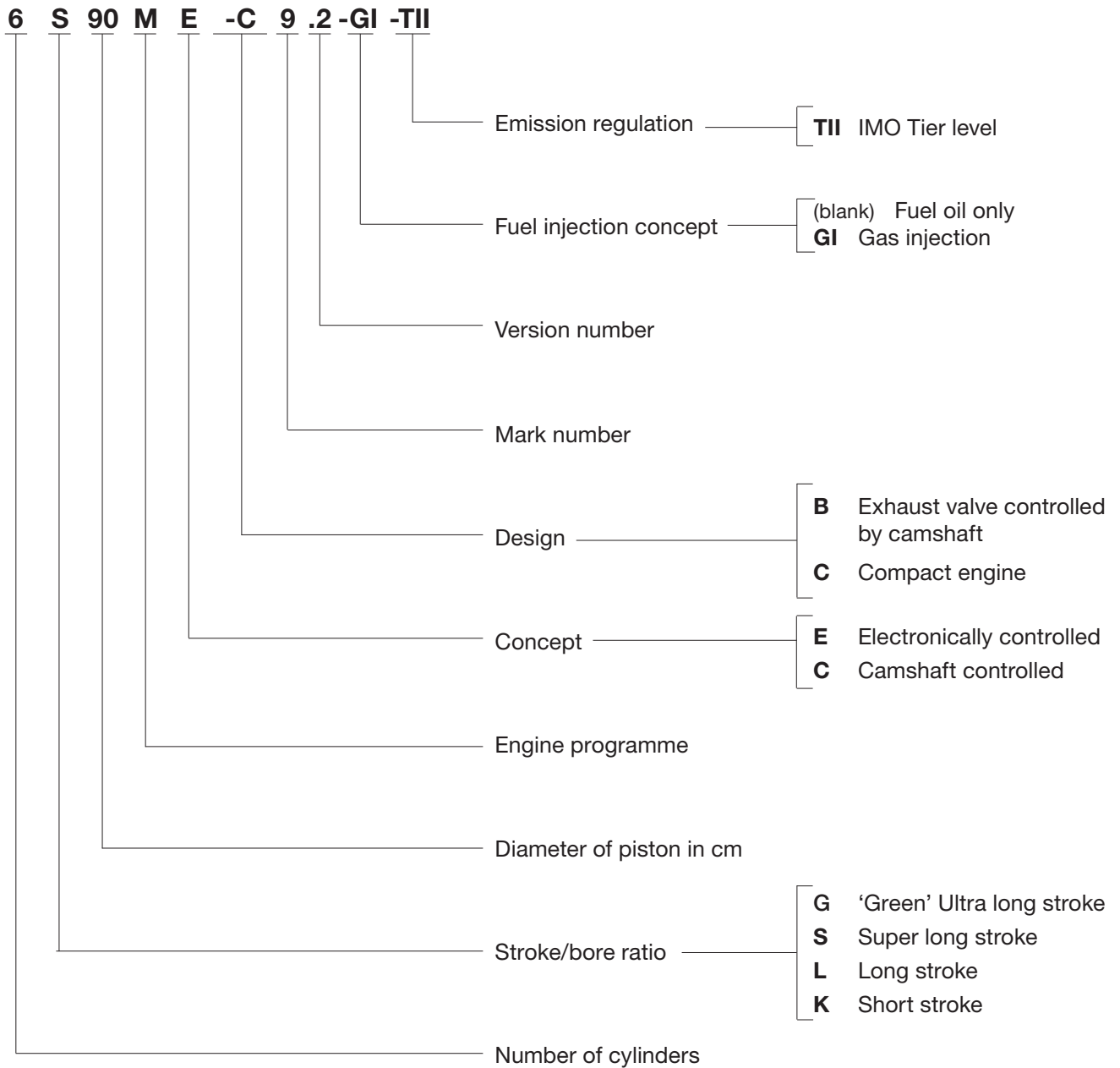



Power, Speed and Fuel Oil

MAN B&W G95ME-C9.5-TII

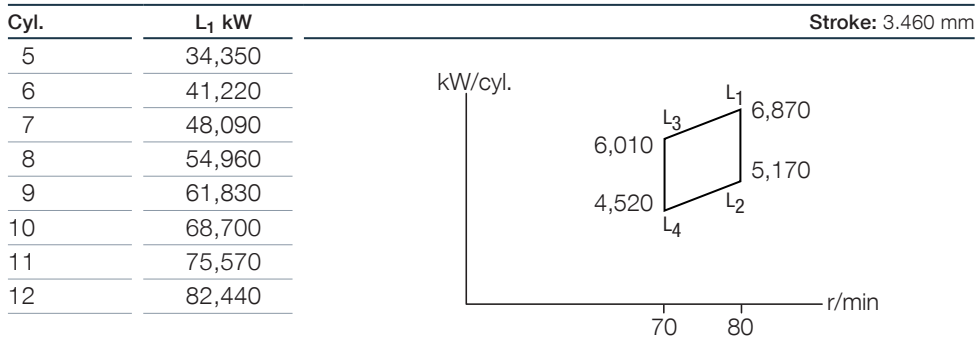

SFOC for engines with layout on L<sub>1</sub> - L<sub>3</sub> line [g/kWh] L<sub>1</sub>/L<sub>3</sub> MEP: 21.0 bar

SFOC optimised load range	Tuning	50%	75%	100%
High load (85%-100%)	-	164.5	162.0	166.0
	ECT	163.5	161.0	169.0
Part load (50%-85%)	VT	161.5	160.5	166.5
	EGB/HPT	161.5	160.5	167.5
	ECT	162.0	161.5	167.5
Low load (25%-70%)	VT	159.5	161.5	166.5
	EGB/HPT	159.5	161.5	167.5

SFOC for engines with layout on L<sub>2</sub> - L<sub>4</sub> line [g/kWh] L<sub>2</sub>/L<sub>4</sub> MEP: 15.8 bar

SFOC optimised load range	Tuning	50%	75%	100%
High load (85%-100%)	-	160.5	156.0	159.0
	ECT	159.5	155.0	162.0
Part load (50%-85%)	VT	157.5	154.5	159.5
	EGB/HPT	157.5	154.5	160.5
	ECT	158.0	155.5	160.5
Low load (25%-70%)	VT	155.5	155.5	159.5
	EGB/HPT	155.5	155.5	160.5

Fig 1.03.01: Power, speed and fuel





## Engine Power Range and Fuel Oil Consumption

### Engine Power

The following tables contain data regarding the power, speed and specific fuel oil consumption of the engine.

Engine power is specified in kW for each cylinder number and layout points L<sub>1</sub>, L<sub>2</sub>, L<sub>3</sub> and L<sub>4</sub>.

Discrepancies between kW and metric horsepower (1 BHP = 75 kpm/s = 0.7355 kW) are a consequence of the rounding off of the BHP values.

L<sub>1</sub> designates nominal maximum continuous rating (nominal MCR), at 100% engine power and 100% engine speed.

L<sub>2</sub>, L<sub>3</sub> and L<sub>4</sub> designate layout points at the other three corners of the layout area, chosen for easy reference.

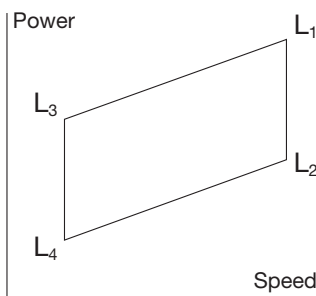

178 51 48-9.0

Fig. 1.04.01: Layout diagram for engine power and speed

Overload corresponds to 110% of the power at MCR, and may be permitted for a limited period of one hour every 12 hours.

The engine power figures given in the tables remain valid up to tropical conditions at sea level as stated in IACS M28 (1978), i.e.:

- Blower inlet temperature ..... 45 °C
- Blower inlet pressure ..... 1,000 mbar
- Seawater temperature..... 32 °C
- Relative humidity .....60%

### Specific Fuel Oil Consumption (SFOC)

The figures given in this folder represent the values obtained when the engine and turbocharger are matched with a view to obtaining the lowest possible SFOC values while also fulfilling the IMO NOX Tier II emission limitations.

Stricter emission limits can be met on request, using proven technologies.

The SFOC figures are given in g/kWh with a tolerance of 5% (at 100% SMCR) and are based on the use of fuel with a lower calorific value of 42,700 kJ/kg (~10,200 kcal/kg) at ISO conditions:

- Ambient air pressure ..... 1,000 mbar
- Ambient air temperature ..... 25 °C
- Cooling water temperature ..... 25 °C

Although the engine will develop the power specified up to tropical ambient conditions, specific fuel oil consumption varies with ambient conditions and fuel oil lower calorific value. For calculation of these changes, see Chapter 2.

### Lubricating oil data

The cylinder oil consumption figures stated in the tables are valid under normal conditions.

During running-in periods and under special conditions, feed rates of up to 1.5 times the stated values should be used.



## Performance Curves

Updated engine and capacities data is available from the CEAS program on [www.marine.man.eu](http://www.marine.man.eu) → 'Two-Stroke' → 'CEAS Engine Calculations'.



## ME Engine Description

Please note that engines built by our licensees are in accordance with MAN Diesel & Turbo drawings and standards but, in certain cases, some local standards may be applied; however, all spare parts are interchangeable with MAN Diesel & Turbo designed parts.

Some components may differ from MAN Diesel & Turbo's design because of local production facilities or the application of local standard components.

In the following, reference is made to the item numbers specified in the 'Extent of Delivery' (EoD) forms, both for the 'Basic' delivery extent and for some 'Options'.

### Bedplate and Main Bearing

The bedplate is made with the thrust bearing in the aft end of the engine. The bedplate consists of high, welded, longitudinal girders and welded cross girders with cast steel bearing supports.

For fitting to the engine seating in the ship, long, elastic holding-down bolts, and hydraulic tightening tools are used.

The bedplate is made without taper for engines mounted on epoxy chocks.

The oil pan, which is made of steel plate and is welded to the bedplate, collects the return oil from the forced lubricating and cooling oil system. The oil outlets from the oil pan are vertical as standard and provided with gratings.

The main bearings consist of thin walled steel shells lined with white metal. The main bearing bottom shell can be rotated out and in by means of special tools in combination with hydraulic tools for lifting the crankshaft. The shells are kept in position by a bearing cap.

### Frame Box

The frame box is of welded design. On the exhaust side, it is provided with relief valves for each cylinder while, on the manoeuvring side, it is provided with a large hinged door for each cylinder. The crosshead guides are welded on to the frame box.

The frame box is bolted to the bedplate. The bedplate, frame box and cylinder frame are tightened together by stay bolts.

### Cylinder Frame and Stuffing Box

The cylinder frame is cast and provided with access covers for cleaning the scavenge air space, if required, and for inspection of scavenge ports and piston rings from the manoeuvring side. Together with the cylinder liner it forms the scavenge air space.

The cylinder frame is fitted with pipes for the piston cooling oil inlet. The scavenge air receiver, turbocharger, air cooler box and gallery brackets are located on the cylinder frame. At the bottom of the cylinder frame there is a piston rod stuffing box, provided with sealing rings for scavenge air, and with oil scraper rings which prevent crankcase oil from coming up into the scavenge air space.

Drains from the scavenge air space and the piston rod stuffing box are located at the bottom of the cylinder frame.

### Cylinder Liner

The cylinder liner is made of alloyed cast iron and is suspended in the cylinder frame with a low-situated flange. The top of the cylinder liner is fitted with a cooling jacket. The cylinder liner has scavenge ports and drilled holes for cylinder lubrication.

Cylinder liners prepared for installation of temperature sensors is basic execution on engines type 90 and K80ME-C9 while an option on all other engines.



### **Cylinder Cover**

The cylinder cover is of forged steel, made in one piece, and has bores for cooling water. It has a central bore for the exhaust valve, and bores for the fuel valves, a starting valve and an indicator valve.

The cylinder cover is attached to the cylinder frame with studs and nuts tightened with hydraulic jacks.

### **Crankshaft**

The crankshaft is of the semi-built type, made from forged or cast steel throws. For engines with 9 cylinders or more, the crankshaft is supplied in two parts.

At the aft end, the crankshaft is provided with the collar for the thrust bearing, a flange for fitting the gear wheel for the step-up gear to the hydraulic power supply unit if fitted on the engine, and the flange for the turning wheel and for the coupling bolts to an intermediate shaft.

At the front end, the crankshaft is fitted with the collar for the axial vibration damper and a flange for the fitting of a tuning wheel. The flange can also be used for a Power Take Off, if so desired.

Coupling bolts and nuts for joining the crankshaft together with the intermediate shaft are not normally supplied.

### **Thrust Bearing**

The propeller thrust is transferred through the thrust collar, the segments, and the bedplate, to the end chocks and engine seating, and thus to the ship's hull.

The thrust bearing is located in the aft end of the engine. The thrust bearing is of the B&W-Michell type, and consists primarily of a thrust collar on the crankshaft, a bearing support, and segments of steel lined with white metal.

Engines with 9 cylinders or more will be specified with the 360° degree type thrust bearing, while the 240° degree type is used in all other engines. MAN Diesel & Turbo's flexible thrust cam design is used for the thrust collar on a range of engine types.

The thrust shaft is an integrated part of the crankshaft and it is lubricated by the engine's lubricating oil system.

### **Step-up Gear**

In case of mechanically, engine driven Hydraulic Power Supply, the main hydraulic oil pumps are driven from the crankshaft via a step-up gear. The step-up gear is lubricated from the main engine system.

### **Turning Gear and Turning Wheel**

The turning wheel is fitted to the thrust shaft, and it is driven by a pinion on the terminal shaft of the turning gear, which is mounted on the bedplate. The turning gear is driven by an electric motor with built-in brake.

A blocking device prevents the main engine from starting when the turning gear is engaged. Engagement and disengagement of the turning gear is effected manually by an axial movement of the pinion.

The control device for the turning gear, consisting of starter and manual control box, can be ordered as an option.

### **Axial Vibration Damper**

The engine is fitted with an axial vibration damper, mounted on the fore end of the crankshaft. The damper consists of a piston and a split-type housing located forward of the foremost main bearing.

The piston is made as an integrated collar on the main crank journal, and the housing is fixed to the main bearing support.



For functional check of the vibration damper a mechanical guide is fitted, while an electronic vibration monitor can be supplied as an option.

### **Tuning Wheel / Torsional Vibration Damper**

A tuning wheel or torsional vibration damper may have to be ordered separately, depending on the final torsional vibration calculations.

### **Connecting Rod**

The connecting rod is made of forged or cast steel and provided with bearing caps for the crosshead and crankpin bearings.

The crosshead and crankpin bearing caps are secured to the connecting rod with studs and nuts tightened by means of hydraulic jacks.

The crosshead bearing consists of a set of thin-walled steel shells, lined with bearing metal. The crosshead bearing cap is in one piece, with an angular cut-out for the piston rod.

The crankpin bearing is provided with thin-walled steel shells, lined with bearing metal. Lube oil is supplied through ducts in the crosshead and connecting rod.

### **Piston**

The piston consists of a piston crown and piston skirt. The piston crown is made of heat-resistant steel. A piston cleaning ring located in the very top of the cylinder liner scrapes off excessive ash and carbon formations on the piston top-land.

The piston has four ring grooves which are hard-chrome plated on both the upper and lower surfaces of the grooves. The uppermost piston ring is of the CPR type (Controlled Pressure Relief), whereas the other three piston rings all have an oblique cut. The uppermost piston ring is higher than the others. All four rings are alu-coated on the outer surface for running-in.

The piston skirt is made of cast iron with a bronze band or Mo coating.

### **Piston Rod**

The piston rod is of forged steel and is surface-hardened on the running surface for the stuffing box. The piston rod is connected to the crosshead with four bolts. The piston rod has a central bore which, in conjunction with a cooling oil pipe, forms the inlet and outlet for cooling oil.

### **Crosshead**

The crosshead is of forged steel and is provided with cast steel guide shoes with white metal on the running surface. The guide shoe is of the low friction type and crosshead bearings of the wide pad design.

The telescopic pipe for oil inlet and the pipe for oil outlet are mounted on the guide shoes.

### **Scavenge Air System**

The air intake to the turbocharger takes place directly from the engine room through the turbocharger intake silencer. From the turbocharger, the air is led via the charging air pipe, air cooler and scavenge air receiver to the scavenge ports of the cylinder liners, see Chapter 14. The scavenge air receiver is of the D-shape design.

### **Scavenge Air Cooler**

For each turbocharger is fitted a scavenge air cooler of the mono-block type designed for sea-water cooling, alternatively, a central cooling system with freshwater can be chosen. The working pressure is up to 4.5 bar.

The scavenge air cooler is so designed that the difference between the scavenge air temperature and the water inlet temperature at specified MCR can be kept at about 12 °C.



### Auxiliary Blower

The engine is provided with electrically-driven scavenge air blowers integrated in the scavenge air cooler. The suction side of the blowers is connected to the scavenge air space after the air cooler.

Between the air cooler and the scavenge air receiver, non-return valves are fitted which automatically close when the auxiliary blowers supply the air.

The auxiliary blowers will start operating consecutively before the engine is started in order to ensure sufficient scavenge air pressure to obtain a safe start.

Further information is given in Chapter 14.

### Exhaust Gas System

From the exhaust valves, exhaust gas is led to the exhaust gas receiver where the fluctuating pressure from the individual cylinders is equalised, and the total volume of gas is led to the turbocharger(s). After the turbocharger(s), the gas is led to the external exhaust pipe system.

Compensators are fitted between the exhaust valves and the receiver, and between the receiver and the turbocharger(s).

The exhaust gas receiver and exhaust pipes are provided with insulation, covered by galvanised steel plating.

A protective grating is installed between the exhaust gas receiver and the turbocharger.

### Exhaust Turbocharger

The engines can be fitted with either MAN, ABB or MHI turbochargers. As an option, MAN TCA turbochargers can be delivered with variable nozzle technology that reduces the fuel consumption at part load by controlling the scavenge air pressure.

The turbocharger selection is described in Chapter 3, and the exhaust gas system in Chapter 15.

### Reversing

Reversing of the engine is performed electronically and controlled by the Engine Control System, by changing the timing of the fuel injection, the exhaust valve activation and the starting valves.

### The Hydraulic Power Supply

The Hydraulic Power Supply (HPS) filters and pressurises the lube oil for use in the hydraulic system. The HPS consists of either mechanically driven (by the engine) main pumps with electrically driven start-up pumps or electrically driven combined main and start-up pumps. The hydraulic pressure is 300 bar.

The mechanically driven HPS is engine driven and mounted aft for engines with chain drive aft (8 cylinders or less), and at the middle for engines with chain drive located in the middle (9 cylinders or more). An electrically driven HPS is usually mounted aft on the engine.

A combined HPS, mechanically driven with electrically driven start-up/back-up pumps with back-up capacity, is available as an option.

### Hydraulic Cylinder Unit

The hydraulic cylinder unit (HCU), one per cylinder, consists of a base plate on which a distributor block is mounted. The distributor block is fitted with one or more accumulators to ensure that the necessary hydraulic oil peak flow is available during the fuel injection sequence.

The distributor block serves as a mechanical support for the hydraulically activated fuel pressure booster and the hydraulically activated exhaust valve actuator. Single-wall piping has been introduced with the 300 bar hydraulic systems.



### **Fuel Oil Pressure Booster and Fuel Oil High Pressure Pipes**

The engine is provided with one hydraulically activated fuel oil pressure booster for each cylinder.

Fuel injection is activated by a multi-way valve (FIVA), which is electronically controlled by the Cylinder Control Unit (CCU) of the Engine Control System.

The fuel oil high-pressure pipes are of the double-wall type with built-in conical support. The pipes are insulated but not heated. On engines type 95-90 and G80ME-C9, a 'fuel oil leakage' system for each cylinder detects fuel oil leakages and immediately stops the injection on the actual cylinder.

Further information is given in Section 7.01.

### **Fuel Valves and Starting Air Valve**

The cylinder cover is equipped with two or three fuel valves, starting air valve, and indicator cock.

The opening of the fuel valves is controlled by the high pressure fuel oil created by the fuel oil pressure booster, and the valves are closed by a spring.

An automatic vent slide allows circulation of fuel oil through the valve and high pressure pipes when the engine is stopped. The vent slide also prevents the compression chamber from being filled up with fuel oil in the event that the valve spindle sticks. Oil from the vent slide and other drains is led away in a closed system.

Supply of starting air is provided by one solenoid valve per cylinder, controlled by the CCUs of the Engine Control System.

The starting valve is opened by control air, timed by the Engine Control System, and is closed by a spring.

Slow turning before starting is a program incorporated in the basic Engine Control System.

The starting air system is described in detail in Section 13.01.

### **Exhaust Valve**

The exhaust valve consists of the valve housing and the valve spindle. The valve housing is of the un-cooled Millenium type and made of cast iron. The housing is provided with a water cooled bottom piece of steel with a flame hardened seat of the W-seat design.

The exhaust valve spindle is a DuraSpindle, the housing provided with a spindle guide.

The exhaust valve is tightened to the cylinder cover with studs and nuts. The exhaust valve is opened hydraulically by the electronic valve activation system and is closed by an air spring.

The exhaust valve is of the low-force design and the operation of the exhaust valve controlled by the FIVA valve, which also activates the fuel injection.

In operation, the valve spindle slowly rotates, driven by the exhaust gas acting on a vane wheel fixed to the spindle.

Sealing of the exhaust valve spindle guide is provided by means of Controlled Oil Level (COL), an oil bath in the bottom of the air cylinder, above the sealing ring. This oil bath lubricates the exhaust valve spindle guide and sealing ring as well.

### **Indicator Cock**

The engine is fitted with an indicator cock to which the PMI pressure transducer is connected.

### **MAN B&W Alpha Cylinder Lubrication**

The electronically controlled MAN B&W Alpha cylinder lubrication system is applied to the ME engines, and controlled by the ME Engine Control System.





The main advantages of the MAN B&W Alpha cylinder lubrication system, compared with the conventional mechanical lubricator, are:

- Improved injection timing
- Increased dosage flexibility
- Constant injection pressure
- Improved oil distribution in the cylinder liner
- Possibility for prelubrication before starting.

More details about the cylinder lubrication system can be found in Chapter 9.

### Gallery Arrangement

The engine is provided with gallery brackets, stanchions, railings and platforms (exclusive of ladders). The brackets are placed at such a height as to provide the best possible overhauling and inspection conditions.

Some main pipes of the engine are suspended from the gallery brackets, and the topmost gallery platform on the manoeuvring side is provided with overhauling holes for the pistons.

The engine is prepared for top bracings on the exhaust side, or on the manoeuvring side.

### Piping Arrangements

The engine is delivered with piping arrangements for:

- Fuel oil
- Heating of fuel oil
- Lubricating oil, piston cooling oil, hydraulic oil
- Cylinder lubricating oil
- Cooling water to scavenge air cooler
- Jacket and turbocharger cooling water
- Cleaning of turbocharger
- Fire extinguishing in scavenge air space
- Starting air
- Control air
- Oil mist detector (required only for make Schaller Automation)
- Various drain pipes.

All piping arrangements are made of steel piping, except the control air and steam heating of fuel pipes, which are made of copper.

The pipes are provided with sockets for local instruments, alarm and safety equipment and, furthermore, with a number of sockets for supplementary signal equipment. Chapter 18 deals with the instrumentation.



**MAN B&W**

---

# Engine Layout and Load Diagrams, SFOC

2

---

**MAN Diesel**

## Engine Layout and Load Diagrams

### Introduction

The effective power 'P' of a diesel engine is proportional to the mean effective pressure  $p_e$  and engine speed 'n', i.e. when using 'c' as a constant:

$$P = c \times p_e \times n$$

so, for constant mep, the power is proportional to the speed:

$$P = c \times n^1 \text{ (for constant mep)}$$

When running with a Fixed Pitch Propeller (FPP), the power may be expressed according to the propeller law as:

$$P = c \times n^3 \text{ (propeller law)}$$

Thus, for the above examples, the power P may be expressed as a power function of the speed 'n' to the power of 'i', i.e.:

$$P = c \times n^i$$

Fig. 2.01.01 shows the relationship for the linear functions,  $y = ax + b$ , using linear scales.

The power functions  $P = c \times n^i$  will be linear functions when using logarithmic scales:

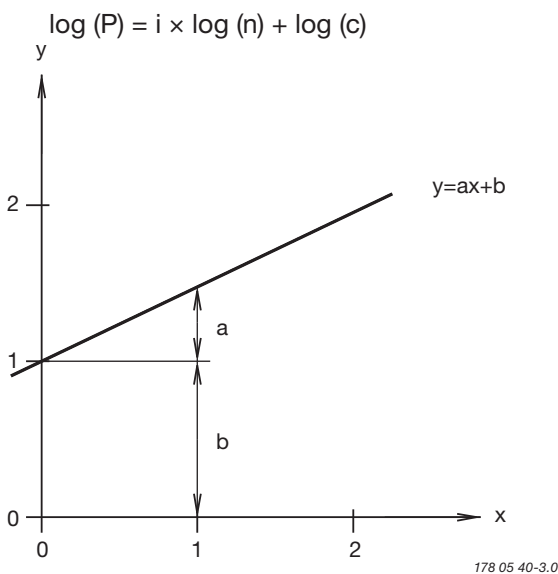

Fig. 2.01.01: Straight lines in linear scales

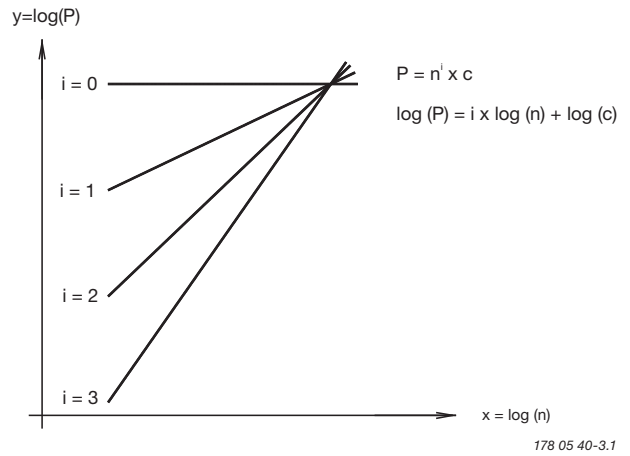

Fig. 2.01.02: Power function curves in logarithmic scales

Thus, propeller curves will be parallel to lines having the inclination  $i = 3$ , and lines with constant mep will be parallel to lines with the inclination  $i = 1$ .

Therefore, in the Layout Diagrams and Load Diagrams for diesel engines, logarithmic scales are used, giving simple diagrams with straight lines.

## Propulsion and Engine Running Points

### Propeller curve

The relation between power and propeller speed for a fixed pitch propeller is as mentioned above described by means of the propeller law, i.e. the third power curve:

$$P = c \times n^3, \text{ in which:}$$

- P = engine power for propulsion
- n = propeller speed
- c = constant

### Propeller design point

Normally, estimates of the necessary propeller power and speed are based on theoretical calculations for loaded ship, and often experimental tank tests, both assuming optimum operating conditions, i.e. a clean hull and good weather. The combination of speed and power obtained may be called the ship's propeller design point (PD),



placed on the light running propeller curve 6. See below figure. On the other hand, some shipyards, and/or propeller manufacturers sometimes use a propeller design point (PD) that incorporates all or part of the so-called sea margin described below.

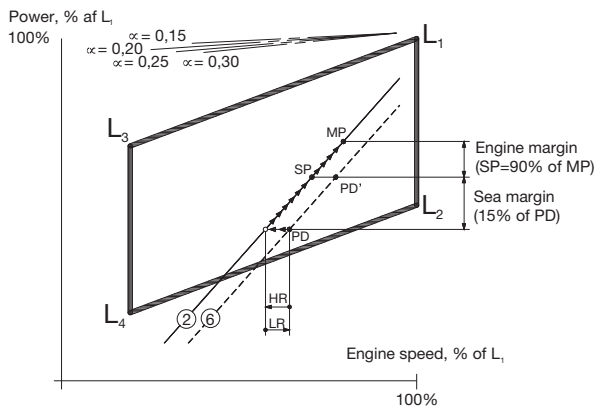

- Line 2 Propulsion curve, fouled hull and heavy weather (heavy running), recommended for engine layout
- Line 6 Propulsion curve, clean hull and calm weather (light running), for propeller layout
- MP Specified MCR for propulsion
- SP Continuous service rating for propulsion
- PD Propeller design point
- HR Heavy running
- LR Light running

178 05 41-5.3

Fig. 2.01.03: Ship propulsion running points and engine layout

**Fouled hull**

When the ship has sailed for some time, the hull and propeller become fouled and the hull’s resistance will increase. Consequently, the ship’s speed will be reduced unless the engine delivers more power to the propeller, i.e. the propeller will be further loaded and will be heavy running (HR).

As modern vessels with a relatively high service speed are prepared with very smooth propeller and hull surfaces, the gradual fouling after sea trial will increase the hull’s resistance and make the propeller heavier running.

**Sea margin and heavy weather**

If, at the same time the weather is bad, with head winds, the ship’s resistance may increase compared to operating in calm weather conditions. When determining the necessary engine power, it is normal practice to add an extra power margin,

the so-called sea margin, which is traditionally about 15% of the propeller design (PD) power.

**Engine layout (heavy propeller)**

When determining the necessary engine layout speed that considers the influence of a heavy running propeller for operating at high extra ship resistance, it is (compared to line 6) recommended to choose a heavier propeller line 2. The propeller curve for clean hull and calm weather line 6 may then be said to represent a ‘light running’ (LR) propeller.

Compared to the heavy engine layout line 2, we recommend using a light running of **3.0-7.0%** for design of the propeller.

**Engine margin**

Besides the sea margin, a so-called ‘engine margin’ of some 10% or 15% is frequently added. The corresponding point is called the ‘specified MCR for propulsion’ (MP), and refers to the fact that the power for point SP is 10% or 15% lower than for point MP.

Point MP is identical to the engine’s specified MCR point (M) unless a main engine driven shaft generator is installed. In such a case, the extra power demand of the shaft generator must also be considered.

**Constant ship speed lines**

The constant ship speed lines  $\alpha$ , are shown at the very top of the figure. They indicate the power required at various propeller speeds in order to keep the same ship speed. It is assumed that, for each ship speed, the optimum propeller diameter is used, taking into consideration the total propulsion efficiency. See definition of  $\alpha$  in Section 2.02.

**Note:**

*Light/heavy running, fouling and sea margin are overlapping terms. Light/heavy running of the propeller refers to hull and propeller deterioration and heavy weather, whereas sea margin i.e. extra power to the propeller, refers to the influence of the wind and the sea. However, the degree of light running must be decided upon experience from the actual trade and hull design of the vessel.*



### Propeller diameter and pitch, influence on the optimum propeller speed

In general, the larger the propeller diameter  $D$ , the lower is the optimum propeller speed and the kW required for a certain design draught and ship speed, see curve D in the figure below.

The maximum possible propeller diameter depends on the given design draught of the ship, and the clearance needed between the propeller and the aft body hull and the keel.

The example shown in the figure is an 80,000 dwt crude oil tanker with a design draught of 12.2 m and a design speed of 14.5 knots.

When the optimum propeller diameter  $D$  is increased from 6.6 m to 7.2 m, the power demand is reduced from about 9,290 kW to 8,820 kW, and the optimum propeller speed is reduced from 120 r/min to 100 r/min, corresponding to the constant ship speed coefficient  $\alpha = 0.28$  (see definition of  $\alpha$  in Section 2.02, page 2).

Once an optimum propeller diameter of maximum 7.2 m has been chosen, the corresponding optimum pitch in this point is given for the design speed of 14.5 knots, i.e.  $P/D = 0.70$ .

However, if the optimum propeller speed of 100 r/min does not suit the preferred / selected main engine speed, a change of pitch away from optimum will only cause a relatively small extra power demand, keeping the same maximum propeller diameter:

- going from 100 to 110 r/min ( $P/D = 0.62$ ) requires 8,900 kW i.e. an extra power demand of 80 kW.
- going from 100 to 91 r/min ( $P/D = 0.81$ ) requires 8,900 kW i.e. an extra power demand of 80 kW.

In both cases the extra power demand is only of 0.9%, and the corresponding 'equal speed curves' are  $\alpha = +0.1$  and  $\alpha = -0.1$ , respectively, so there is a certain interval of propeller speeds in which the 'power penalty' is very limited.

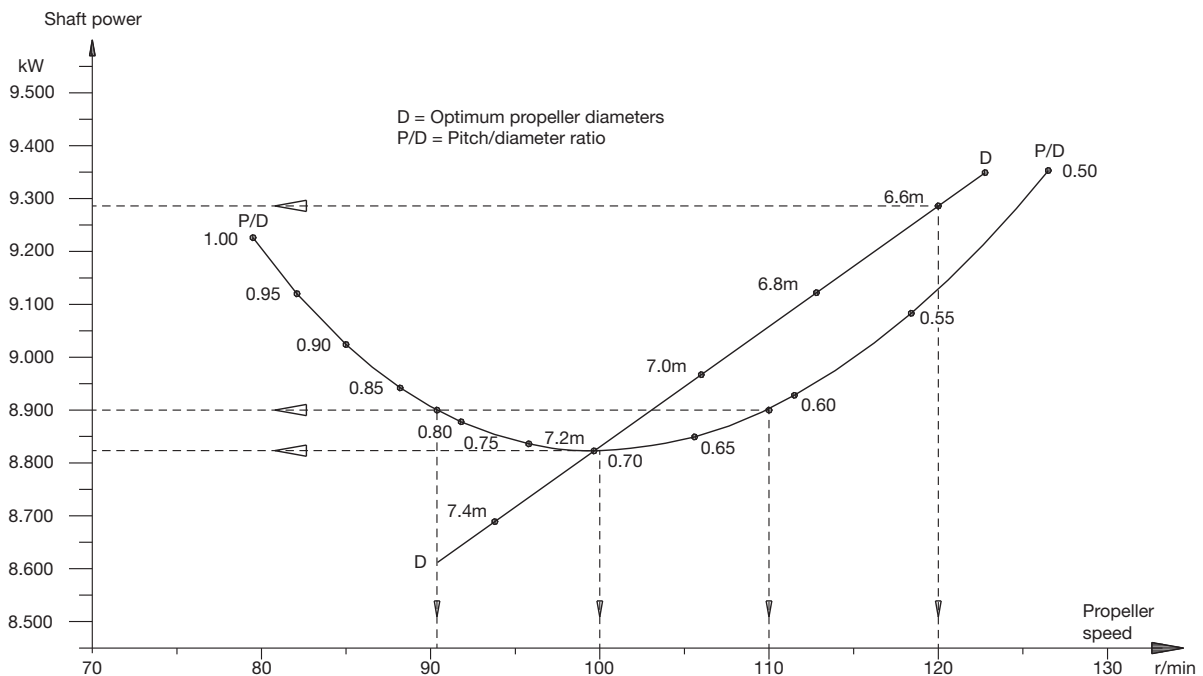

178 47 03-2.0

Fig. 2.02.01: Influence of diameter and pitch on propeller design



Constant ship speed lines

The constant ship speed lines α, are shown at the very top of Fig. 2.02.02. These lines indicate the power required at various propeller speeds to keep the same ship speed provided that the optimum propeller diameter with an optimum pitch diameter ratio is used at any given speed, taking into consideration the total propulsion efficiency.

Normally, the following relation between necessary power and propeller speed can be assumed:

$$P_2 = P_1 \times (n_2/n_1)^\alpha$$

where:

P = Propulsion power

n = Propeller speed, and

α = the constant ship speed coefficient.

For any combination of power and speed, each point on lines parallel to the ship speed lines gives the same ship speed.

When such a constant ship speed line is drawn into the layout diagram through a specified propulsion MCR point 'MP<sub>1</sub>', selected in the layout

area and parallel to one of the α-lines, another specified propulsion MCR point 'MP<sub>2</sub>' upon this line can be chosen to give the ship the same speed for the new combination of engine power and speed.

Fig. 2.02.02 shows an example of the required power speed point MP<sub>1</sub>, through which a constant ship speed curve α = 0.25 is drawn, obtaining point MP<sub>2</sub> with a lower engine power and a lower engine speed but achieving the same ship speed.

Provided the optimum pitch/diameter ratio is used for a given propeller diameter the following data applies when changing the propeller diameter:

for general cargo, bulk carriers and tankers  
α = 0.25 -0.30

and for reefers and container vessels  
α = 0.15 -0.25

When changing the propeller speed by changing the pitch diameter ratio, the α constant will be different, see above.

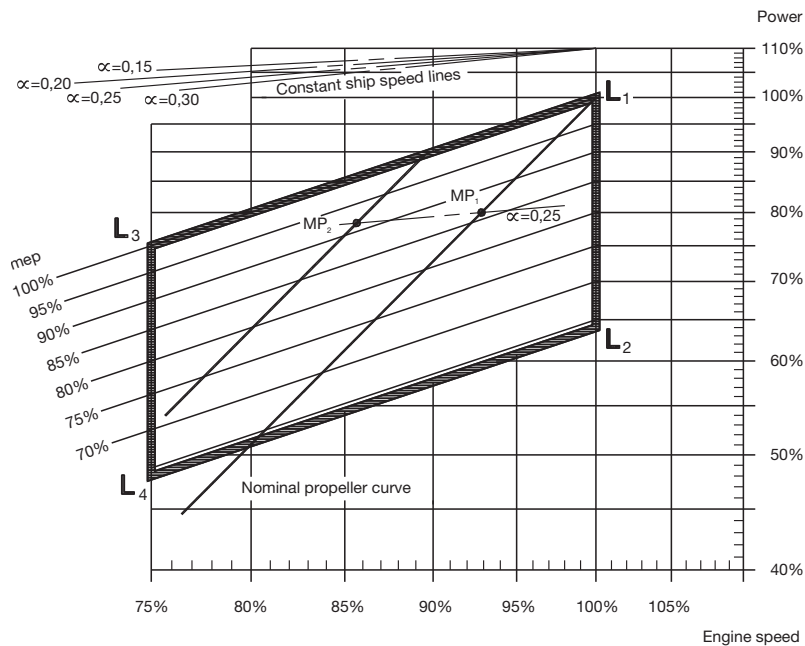

178 05 66-7.0

Fig. 2.02.02: Layout diagram and constant ship speed lines



Layout Diagram Sizes

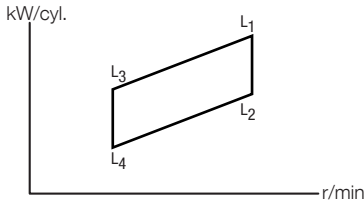

100 - 75% power and  
100 - 74% speed range  
valid for the types:  
G60ME-C9.5

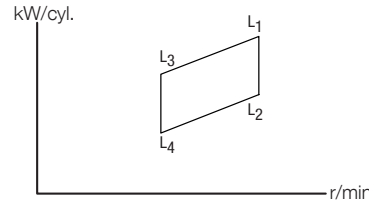

100 - 75% power and  
100 - 81% speed range  
valid for the types:  
G80ME-C9.5/GI

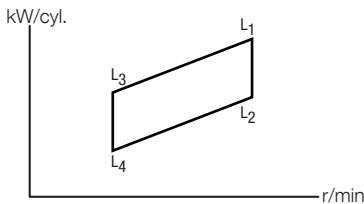

100 - 75% power and  
100 - 75% speed range  
valid for the types:  
G70ME-C9.5/GI

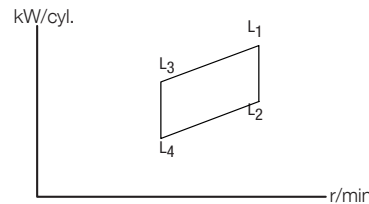

100 - 80% power and  
100 - 81% speed range  
valid for the types:  
S90ME-C9.5/GI  
S65ME-C8.5/GI  
S46ME-B8.5

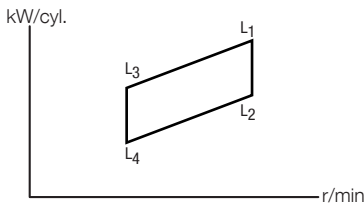

100 - 80% power and  
100 - 76% speed range  
valid for the types:  
S50ME-B9.5  
S40ME-B9.5  
S35ME-B9.5  
S30ME-B9.5

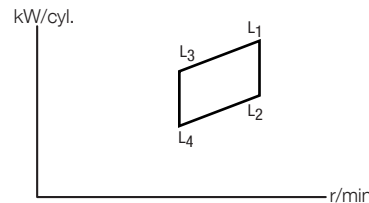

100 - 80% power and  
100 - 84% speed range  
valid for the types:  
L70ME-C8.5/GI

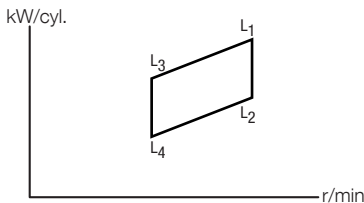

100 - 75% power and  
100 - 78% speed range  
valid for the types:  
G45ME-C9.5/GI

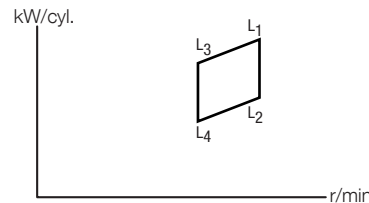

100 - 75% power and  
100 - 88% speed range  
valid for the types:  
G95ME-C9.5/GI

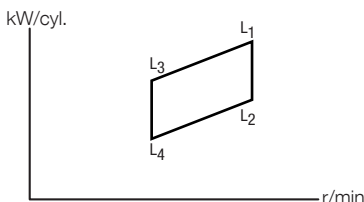

100 - 75% power and  
100 - 79% speed range  
valid for the types:  
G50ME-C9.5/GI  
G40ME-C9.5/GI

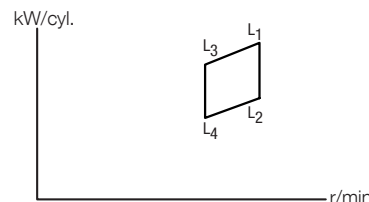

100 - 80% power and  
100 - 86% speed range  
valid for the types:  
S90ME-C10.5/GI

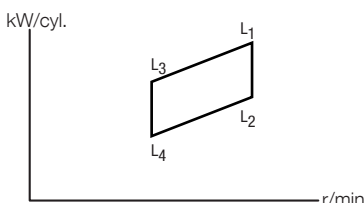

100 - 80% power and  
100 - 79% speed range  
valid for the types:  
G50ME-B9.5

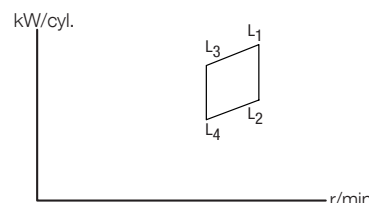

100 - 80% power and  
100 - 92% speed range  
valid for the types:  
S80ME-C9.5/GI

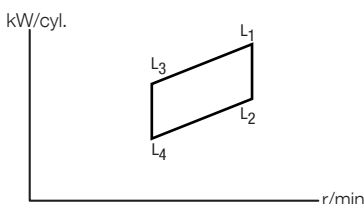

100 - 80% power and  
100 - 80% speed range  
valid for the types:  
S70ME-C8.5/GI  
S60ME-C8.5/GI  
S50ME-C8.5/GI

See also Section 2.05 for actual project.

178 66 02-4.0

Fig. 2.03.01 Layout diagram sizes





## Engine Layout and Load Diagram

### Engine Layout Diagram

An engine's layout diagram is limited by two constant mean effective pressure (mep) lines  $L_1-L_3$  and  $L_2-L_4$ , and by two constant engine speed lines  $L_1-L_2$  and  $L_3-L_4$ . The  $L_1$  point refers to the engine's nominal maximum continuous rating, see Fig. 2.04.01.

Within the layout area there is full freedom to select the engine's specified SMCR point M which suits the demand for propeller power and speed for the ship.

On the horizontal axis the engine speed and on the vertical axis the engine power are shown on percentage scales. The scales are logarithmic which means that, in this diagram, power function curves like propeller curves (3rd power), constant mean effective pressure curves (1st power) and constant ship speed curves (0.15 to 0.30 power) are straight lines.

### Specified maximum continuous rating (M)

Based on the propulsion and engine running points, as previously found, the layout diagram of a relevant main engine may be drawn-in. The SMCR point (M) must be inside the limitation lines of the layout diagram; if it is not, the propeller speed will have to be changed or another main engine type must be chosen. The selected SMCR has an influence on the turbocharger and its matching and the compression ratio.

For ME and ME-C/-GI engines, the timing of the fuel injection and the exhaust valve activation are electronically optimised over a wide operating range of the engine.

For ME-B engines, only the fuel injection (and not the exhaust valve activation) is electronically controlled over a wide operating range of the engine.

For a standard high-load optimised engine, the lowest specific fuel oil consumption for the ME and ME-C engines is obtained at 70% and for MC/MC-C/ME-B engines at 80% of the SMCR point (M).

For ME-C-GI engines operating on LNG, a further SFOC reduction can be obtained.

### Continuous service rating (S)

The continuous service rating is the power needed in service – including the specified sea margin and heavy/light running factor of the propeller – at which the engine is to operate, and point S is identical to the service propulsion point (SP) unless a main engine driven shaft generator is installed.

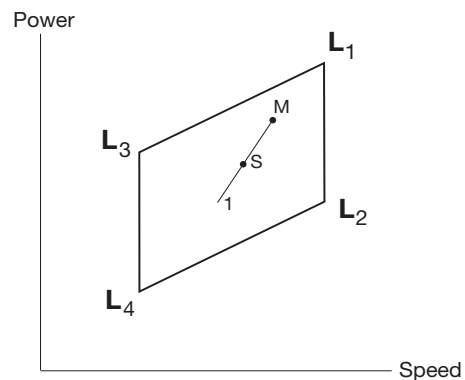

178 60 85-8.1

Fig. 2.04.01: Engine layout diagram



## Engine Load Diagram

### Definitions

The engine's load diagram, see Fig. 2.04.02, defines the power and speed limits for continuous as well as overload operation of an installed engine having a specified MCR point M that confirms the ship's specification.

The service points of the installed engine incorporate the engine power required for ship propulsion and shaft generator, if installed.

### Operating curves and limits for continuous operation

The continuous service range is limited by four lines: 4, 5, 7 and 3 (9), see Fig. 2.04.02. The propeller curves, line 1, 2 and 6 in the load diagram are also described below.

#### Line 1:

Propeller curve through specified MCR (M), engine layout curve.

#### Line 2:

Propeller curve, fouled hull and heavy weather – heavy running.

#### Line 3 and line 9:

Line 3 represents the maximum acceptable speed for continuous operation, i.e. 105% of M.

During trial conditions the maximum speed may be extended to 107% of M, see line 9.

The above limits may in general be extended to 105% and during trial conditions to 107% of the nominal  $L_1$  speed of the engine, provided the torsional vibration conditions permit.

The overspeed set-point is 109% of the speed in M, however, it may be moved to 109% of the *nominal speed* in  $L_1$ , provided that torsional vibration conditions permit.

Engine shaft power, % of A

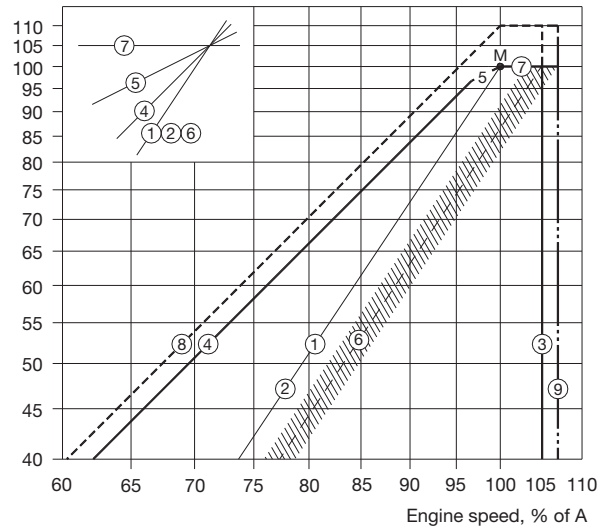

Regarding 'i' in the power function  $P = c \times n^i$ , see page 2.01.

M Specified MCR point

Line 1 Propeller curve through point M (i = 3) (engine layout curve)

Line 2 Propeller curve, fouled hull and heavy weather – heavy running (i = 3)

Line 3 Speed limit

Line 4 Torque/speed limit (i = 2)

Line 5 Mean effective pressure limit (i = 1)

Line 6 Propeller curve, clean hull and calm weather – light running (i = 3), for propeller layout

Line 7 Power limit for continuous running (i = 0)

Line 8 Overload limit

Line 9 Speed limit at sea trial

178 05 42-7.6

Fig. 2.04.02: Standard engine load diagram

Running at low load above 100% of the nominal  $L_1$  speed of the engine is, however, to be avoided for extended periods. Only plants with controllable pitch propellers can reach this light running area.

#### Line 4:

Represents the limit at which an ample air supply is available for combustion and imposes a limitation on the maximum combination of torque and speed.

*Line 5:*

Represents the maximum mean effective pressure level (mep), which can be accepted for continuous operation.

*Line 6:*

Propeller curve, clean hull and calm weather – light running, used for propeller layout/design.

*Line 7:*

Represents the maximum power for continuous operation.

**Limits for overload operation**

The overload service range is limited as follows:

*Line 8:*

Represents the overload operation limitations.

The area between lines 4, 5, 7 and the heavy dashed line 8 is available for overload running for limited periods only (1 hour per 12 hours).

*Line 9:*

Speed limit at sea trial.

**Limits for low load running**

As the fuel injection for ME engines is automatically controlled over the entire power range, the engine is able to operate down to around 15-20% of the nominal  $L_1$  speed, whereas for MC/MC-C engines it is around 20-25% (electronic governor).

**Recommendation**

Continuous operation without limitations is allowed only within the area limited by lines 4, 5, 7 and 3 of the load diagram, except on low load operation for CP propeller plants mentioned in the previous section.

The area between lines 4 and 1 is available for operation in shallow waters, heavy weather and during acceleration, i.e. for non-steady operation without any strict time limitation.

After some time in operation, the ship's hull and propeller will be fouled, resulting in heavier running of the propeller, i.e. the propeller curve will move to the left from line 6 towards line 2, and extra power is required for propulsion in order to keep the ship's speed.

In calm weather conditions, the extent of heavy running of the propeller will indicate the need for cleaning the hull and possibly polishing the propeller.

Once the specified MCR has been chosen, the capacities of the auxiliary equipment will be adapted to the specified MCR, and the turbo-charger specification and the compression ratio will be selected.

If the specified MCR is to be increased later on, this may involve a change of the pump and cooler capacities, change of the fuel valve nozzles, adjusting of the cylinder liner cooling, as well as rematching of the turbocharger or even a change to a larger size of turbocharger. In some cases it can also require larger dimensions of the piping systems.

It is therefore of utmost importance to consider, already at the project stage, if the specification should be prepared for a later power increase. This is to be indicated in the Extent of Delivery.



## Extended load diagram for ships operating in extreme heavy running conditions

When a ship with fixed pitch propeller is operating in normal sea service, it will in general be operating in the hatched area around the design propeller curve 6, as shown on the standard load diagram in Fig. 2.04.02.

Sometimes, when operating in heavy weather, the fixed pitch propeller performance will be more heavy running, i.e. for equal power absorption of the propeller, the propeller speed will be lower and the propeller curve will move to the left.

As the low speed main engines are directly coupled to the propeller, the engine has to follow the propeller performance, i.e. also in heavy running propeller situations. For this type of operation, there is normally enough margin in the load area between line 6 and the normal torque/speed limitation line 4, see Fig. 2.04.02. To the left of line 4 in torque-rich operation, the engine will lack air from the turbocharger to the combustion process, i.e. the heat load limits may be exceeded and bearing loads might also become too high.

For some special ships and operating conditions, it would be an advantage - when occasionally needed - to be able to operate the propeller/main engine as much as possible to the left of line 6, but inside the torque/speed limit, line 4.

Such cases could be for:

- ships sailing in areas with very heavy weather
- ships operating in ice
- ships with two fixed pitch propellers/two main engines, where one propeller/one engine is de-clutched for one or the other reason.

The increase of the operating speed range between line 6 and line 4 of the standard load diagram, see Fig. 2.04.02, may be carried out as shown for the following engine Example with an extended load diagram for speed derated engine with increased light running.

### Extended load diagram for speed derated engines with increased light running

The maximum speed limit (line 3) of the engines is 105% of the SMCR (Specified Maximum Continuous Rating) speed, as shown in Fig. 2.04.02.

However, for speed and, thereby, power derated engines it is possible to extend the maximum speed limit to 105% of the engine's nominal MCR speed, line 3', but only provided that the torsional vibration conditions permit this. Thus, the shafting, with regard to torsional vibrations, has to be approved by the classification society in question, based on the extended maximum speed limit.

When choosing an increased light running to be used for the design of the propeller, the load diagram area may be extended from line 3 to line 3', as shown in Fig. 2.04.03, and the propeller/main engine operating curve 6 may have a correspondingly increased heavy running margin before exceeding the torque/speed limit, line 4.

A corresponding slight reduction of the propeller efficiency may be the result, due to the higher propeller design speed used.

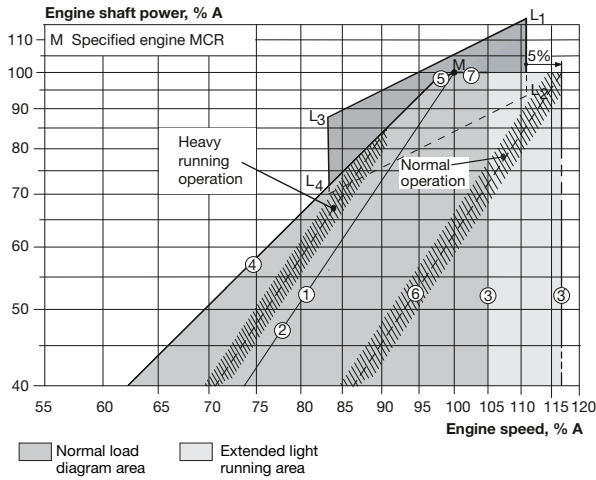

- Line 1: Propeller curve through SMCR point (M)  
- layout curve for engine
- Line 2: Heavy propeller curve  
- fouled hull and heavy seas
- Line 3: Speed limit
- Line 3': Extended speed limit, provided torsional vibration conditions permit
- Line 4: Torque/speed limit
- Line 5: Mean effective pressure limit
- Line 6: Increased light running propeller curve  
- clean hull and calm weather  
- layout curve for propeller
- Line 7: Power limit for continuous running

178 60 79-9.1

Fig. 2.04.03: Extended load diagram for speed derated engine with increased light running

### Examples of the use of the Load Diagram

In the following are some examples illustrating the flexibility of the layout and load diagrams.

- Example 1 shows how to place the load diagram for an engine without shaft generator coupled to a fixed pitch propeller.
- Example 2 shows the same layout for an engine with fixed pitch propeller (example 1), but with a shaft generator.
- Example 3 is a special case of example 2, where the specified MCR is placed near the top of the layout diagram. In this case the shaft generator is cut off, and the GenSets used when the engine runs at specified MCR. This makes it possible to choose a smaller engine with a lower power output, and with changed specified MCR.
- Example 4 shows diagrams for an engine coupled to a controllable pitch propeller, with or without a shaft generator, constant speed or combinator curve operation.

For a specific project, the layout diagram for actual project shown later in this chapter may be used for construction of the actual load diagram.



**Example 1: Normal running conditions.  
Engine coupled to fixed pitch propeller (FPP) and without shaft generator**

**Layout diagram**

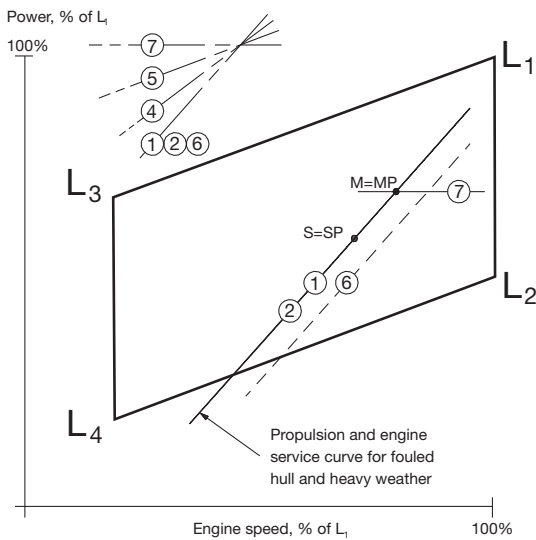

**Load diagram**

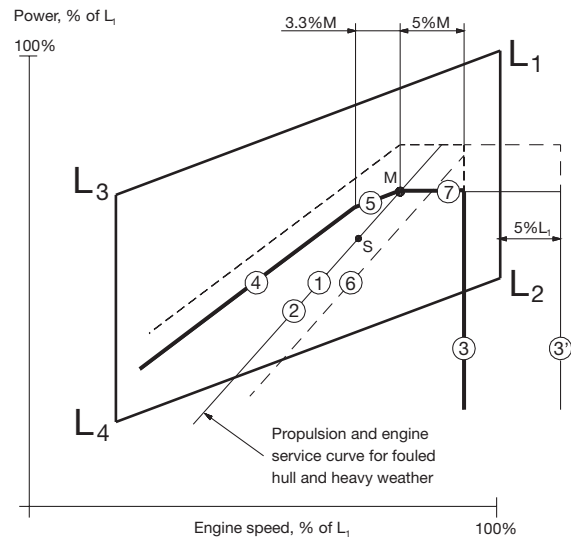

- M Specified MCR of engine
- S Continuous service rating of engine
- MP Specified MCR for propulsion
- SP Continuous service rating of propulsion

The specified MCR (M) and its propeller curve 1 will normally be selected on the engine service curve 2.

Once point M has been selected in the layout diagram, the load diagram can be drawn, as shown in the figure, and hence the actual load limitation lines of the diesel engine may be found by using the inclinations from the construction lines and the %-figures stated.

178 05 44-0.9

Fig. 2.04.04: Normal running conditions. Engine coupled to a fixed pitch propeller (FPP) and without a shaft generator



**Example 2: Normal running conditions.  
Engine coupled to fixed pitch propeller (FPP) and with shaft generator**

**Layout diagram**

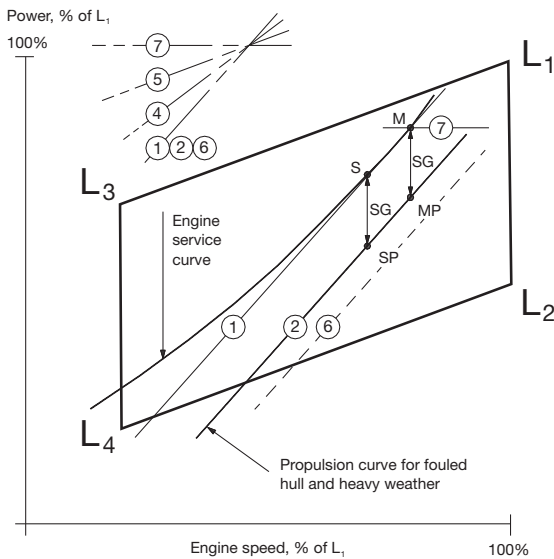

**Load diagram**

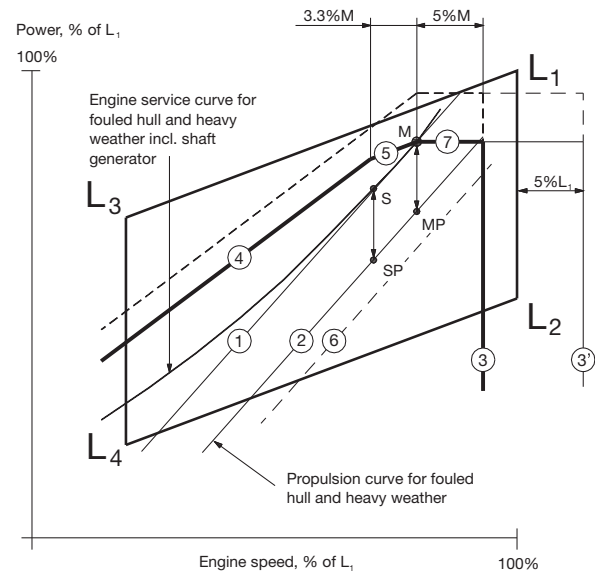

- M Specified MCR of engine
- S Continuous service rating of engine
- MP Specified MCR for propulsion
- SP Continuous service rating of propulsion
- SG Shaft generator power

In example 2 a shaft generator (SG) is installed, and therefore the service power of the engine also has to incorporate the extra shaft power required for the shaft generator's electrical power production.

In the figure, the engine service curve shown for heavy running incorporates this extra power.

The specified MCR M will then be chosen and the load diagram can be drawn as shown in the figure.

178 05 48-8.9

Fig. 2.04.06: Normal running conditions. Engine coupled to a fixed pitch propeller (FPP) and with a shaft generator



**Example 3: Special running conditions.  
Engine coupled to fixed pitch propeller (FPP) and with shaft generator**

**Layout diagram**

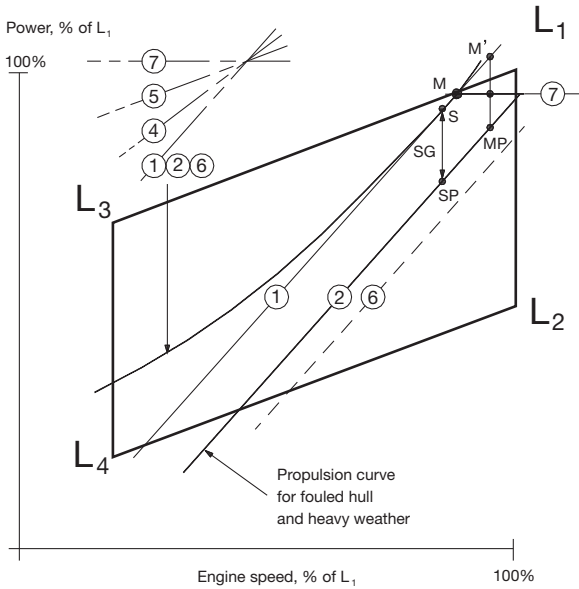

**Load diagram**

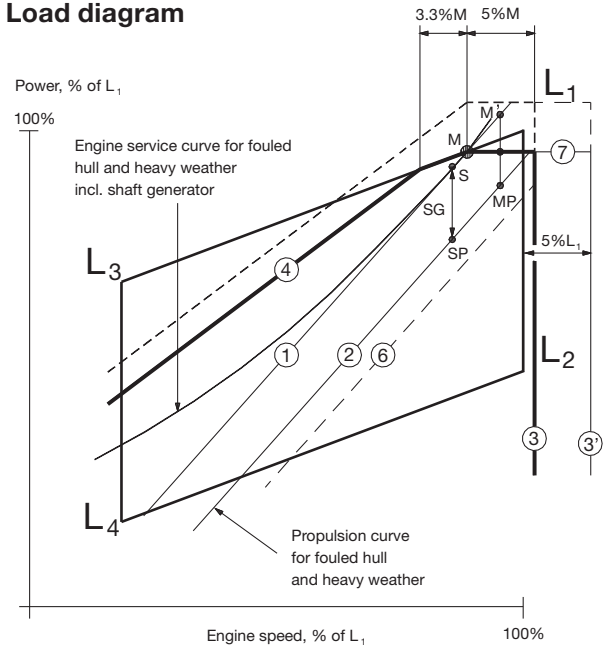

- M Specified MCR of engine
- S Continuous service rating of engine
- MP Specified MCR for propulsion
- SP Continuous service rating of propulsion
- SG Shaft generator

**Point M of the load diagram is found:**  
 Line 1 Propeller curve through point S  
 Point M Intersection between line 1 and line  $L_1 - L_3$

Also for this special case in example 3, a shaft generator is installed but, compared to example 2, this case has a specified MCR for propulsion, MP, placed at the top of the layout diagram.

This involves that the intended specified MCR of the engine  $M'$  will be placed outside the top of the layout diagram.

One solution could be to choose a larger diesel engine with an extra cylinder, but another and cheaper solution is to reduce the electrical power production of the shaft generator when running in the upper propulsion power range.

In choosing the latter solution, the required specified MCR power can be reduced from point  $M'$  to point M as shown. Therefore, when running in the upper propulsion power range, a diesel generator has to take over all or part of the electrical power production.

However, such a situation will seldom occur, as ships are rather infrequently running in the upper propulsion power range.

Point M, having the highest possible power, is then found at the intersection of line  $L_1 - L_3$  with line 1 and the corresponding load diagram is drawn.

178 06 35-1.9

Fig. 2.04.07: Special running conditions. Engine coupled to a fixed pitch propeller (FPP) and with a shaft generator



Example 4: Engine coupled to controllable pitch propeller (CPP) with or without shaft generator

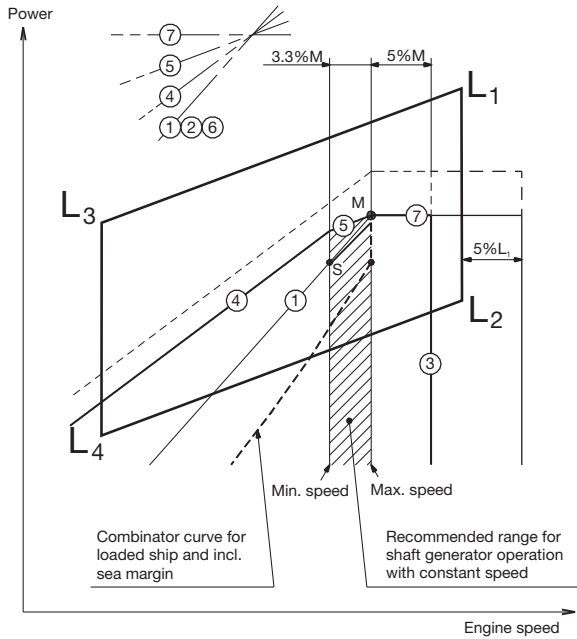

M Specified MCR of engine  
 S Continuous service rating of engine

178 39 31-4.5

Fig. 2.04.08: Engine with Controllable Pitch Propeller (CPP), with or without a shaft generator

Layout diagram - without shaft generator

If a controllable pitch propeller (CPP) is applied, the combinator curve (of the propeller) will normally be selected for loaded ship including sea margin.

The combinator curve may for a given propeller speed have a given propeller pitch, and this may be heavy running in heavy weather like for a fixed pitch propeller.

Therefore it is recommended to use a light running combinator curve (the dotted curve which includes the sea power margin) as shown in the figure to obtain an increased operation margin of the diesel engine in heavy weather to the limit indicated by curves 4 and 5.

Layout diagram - with shaft generator

The hatched area shows the recommended speed range between 100% and 96.7% of the specified MCR speed for an engine with shaft generator running at constant speed.

The service point S can be located at any point within the hatched area.

The procedure shown in examples 2 and 3 for engines with FPP can also be applied here for engines with CPP running with a combinator curve.

Load diagram

Therefore, when the engine's specified MCR point (M) has been chosen including engine margin, sea margin and the power for a shaft generator, if installed, point M may be used in the load diagram, which can then be drawn.

The position of the combinator curve ensures the maximum load range within the permitted speed range for engine operation, and it still leaves a reasonable margin to the limit indicated by curves 4 and 5.



### Diagram for actual project

This figure contains a layout diagram that can be used for constructing the load diagram for an actual project, using the %-figures stated and the inclinations of the lines.

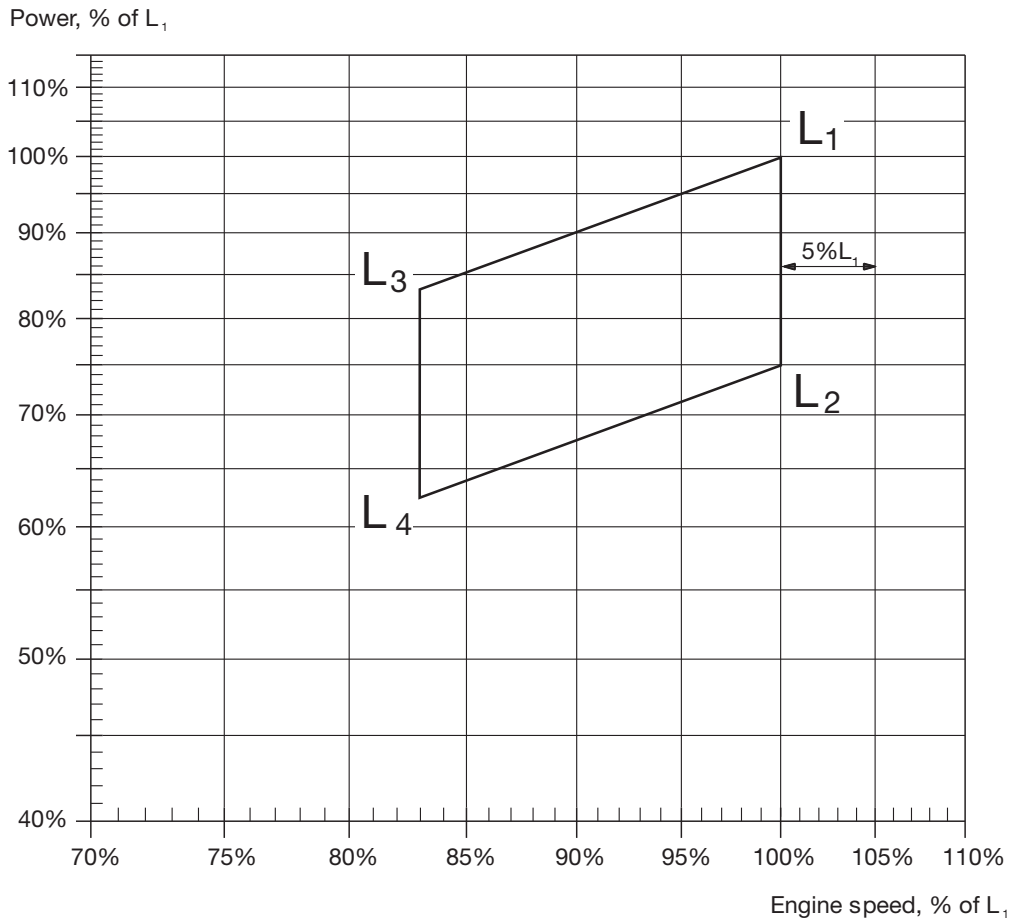
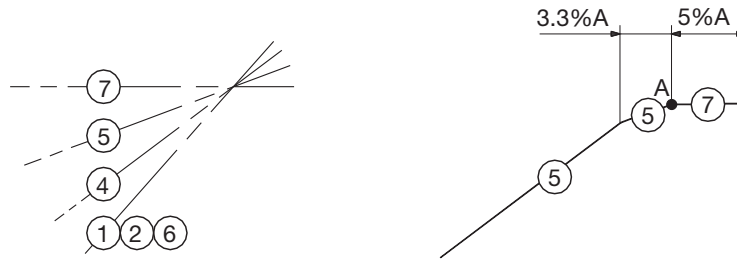

178 66 12-0.0

Fig. 2.05.01: Construction of layout diagram



## **Specific Fuel Oil Consumption, ME versus MC engines**

**This section is not applicable**



### SFOC for High Efficiency Turbochargers

All ME/ME-C engines types 50 bore and above are as standard fitted with high efficiency turbochargers, option: 4 59 104.

The high efficiency turbocharger is applied to the engine in the basic design with the view to obtaining the lowest possible Specific Fuel Oil Consumption (SFOC) values, see example in Fig. 2.07.01.

For standard high load optimised ME/ME-C engines the lowest SFOC at part-load running may be obtained at 80% of the specified MCR.

For more information visit: [www.marine.man.eu](http://www.marine.man.eu) → 'Two-Stroke' → 'Turbocharger Selection'.

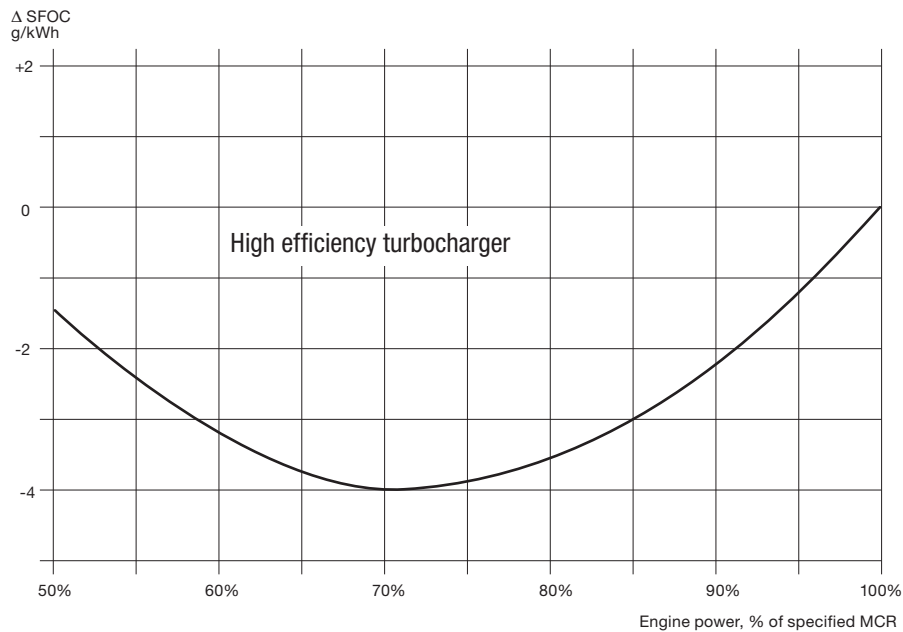

178 60 95-4.3

Fig. 2.07.01: Example of part load SFOC curves for high efficiency turbochargers



### SFOC reference conditions and guarantee

#### SFOC at reference conditions

The SFOC is given in **g/kWh** based on the reference ambient conditions stated in ISO 3046-1:2002(E) and ISO 15550:2002(E):

- 1,000 mbar ambient air pressure
- 25 °C ambient air temperature
- 25 °C scavenge air coolant temperature

and is related to a fuel oil with a lower calorific value of 42,700 kJ/kg (~10,200 kcal/kg).

Any discrepancies between g/kWh and g/BHP<sub>h</sub> are due to the rounding of numbers for the latter.

For lower calorific values and for ambient conditions that are different from the ISO reference conditions, the SFOC will be adjusted according to the conversion factors in the table below.

Parameter	Condition change	With $P_{max}$ adjusted	Without $P_{max}$ adjusted
		SFOC change	SFOC change
Scav. air coolant temperature	per 10 °C rise	+ 0.60%	+ 0.41%
Blower inlet temperature	per 10 °C rise	+ 0.20%	+ 0.71%
Blower inlet pressure	per 10 mbar rise	- 0.02%	- 0.05%
Fuel oil lower calorific value	rise 1% (42,700 kJ/kg)	-1.00%	- 1.00%

With for instance 1 °C increase of the scavenge air coolant temperature, a corresponding 1 °C increase of the scavenge air temperature will occur and involves an SFOC increase of 0.06% if  $p_{max}$  is adjusted to the same value.

#### SFOC guarantee

The Energy Efficiency Design Index (EEDI) has increased the focus on part- load SFOC. We therefore offer the option of selecting the SFOC guarantee at a load point in the range between 50% and 100%, EoD: 4 02 002.

All engine design criteria, e.g. heat load, bearing load and mechanical stresses on the construction are defined at 100% load independent of the guarantee point selected. This means that turbo-charger matching, engine adjustment and engine load calibration must also be performed at 100% independent of guarantee point. At 100% load, the SFOC tolerance is 5%.

When choosing an SFOC guarantee below 100%, the tolerances, which were previously compensated for by the matching, adjustment and calibration at 100%, will affect engine running at the lower SFOC guarantee load point. This includes tolerances on measurement equipment, engine process control and turbocharger performance.

Consequently, SFOC guarantee tolerances are:

- 100% – 85%: 5% tolerance
- 84% – 65%: 6% tolerance
- 64% – 50%: 7% tolerance

*Please note that the SFOC guarantee can only be given in one (1) load point.*

#### Recommended cooling water temperature during normal operation

In general, it is recommended to operate the main engine with the lowest possible cooling water temperature to the air coolers, as this will reduce the fuel consumption of the engine, i.e. the engine performance will be improved.

However, shipyards often specify a constant (maximum) central cooling water temperature of 36 °C, not only for tropical ambient temperature conditions, but also for lower ambient temperature conditions. The purpose is probably to reduce the electric power consumption of the cooling water pumps and/or to reduce water condensation in the air coolers.

Thus, when operating with 36 °C cooling water instead of for example 10 °C (to the air coolers), the specific fuel oil consumption will increase by approx. 2 g/kWh.



## Examples of Graphic Calculation of SFOC

The examples shown in Figs. 2.09 and 2.10 are valid for a standard high-load optimised engine.

The following Diagrams a, b and c, valid for fixed pitch propeller (b) and constant speed (c), respectively, show the reduction of SFOC in g/kWh, relative to the SFOC for the nominal MCR  $L_1$  rating.

The solid lines are valid at 100%, 70% and 50% of SMCR point M.

Point M is drawn into the above-mentioned Diagrams b or c. A straight line along the constant mep curves (parallel to  $L_1-L_3$ ) is drawn through point M. The intersections of this line and the curves indicate the reduction in specific fuel oil consumption at 100, 70 and 50% of the SMCR point M, related to the SFOC stated for the nominal MCR  $L_1$  rating.

An example of the calculated SFOC curves are shown in Diagram a, and is valid for an engine with fixed pitch propeller, see Fig. 2.10.01.

For examples based on part-load and low-load optimised engines, please refer to our publication:

*SFOC Optimisation Methods  
For MAN B&W Two-stroke IMO Tier II Engines*

which is available at [www.marine.man.eu](http://www.marine.man.eu) → 'Two-Stroke' → 'Technical Papers'.

SFOC calculations can be made in the CEAS application, see Section 20.02.



SFOC Calculations for 6G95ME-C9.5-TII

Data at nominal MCR (L <sub>r</sub> )			SFOC at nominal MCR (L <sub>r</sub> )
			high efficiency TC
Engine	kW	r/min	g/kWh
5G95ME-C9.5-TII	34,350	80	166.0
6G95ME-C9.5-TII	41,220		
7G95ME-C9.5-TII	48,090		
8G95ME-C9.5-TII	54,960		
9G95ME-C9.5-TII	61,830		
10G95ME-C9.5-TII	68,700		
11G95ME-C9.5-TII	75,570		
12G95ME-C9.5-TII	82,440		

Data SMCR point (M):	
	cyl. No.
Power: 100% of (M)	kW
Speed: 100% of (M)	r/min
SFOC found:	g/kWh

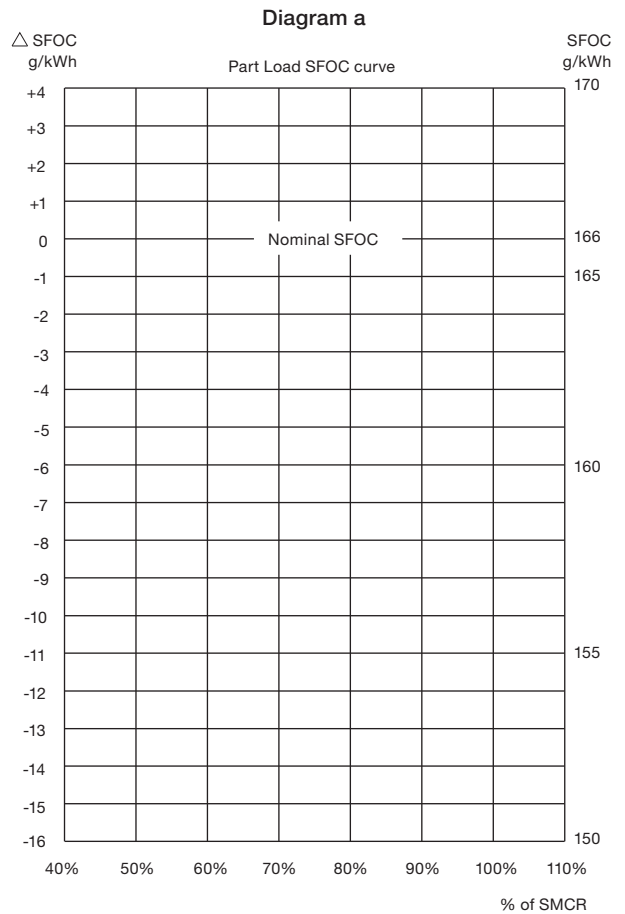





### SFOC for 6G95ME-C9.5-TII with fixed pitch propeller

Diagram b1

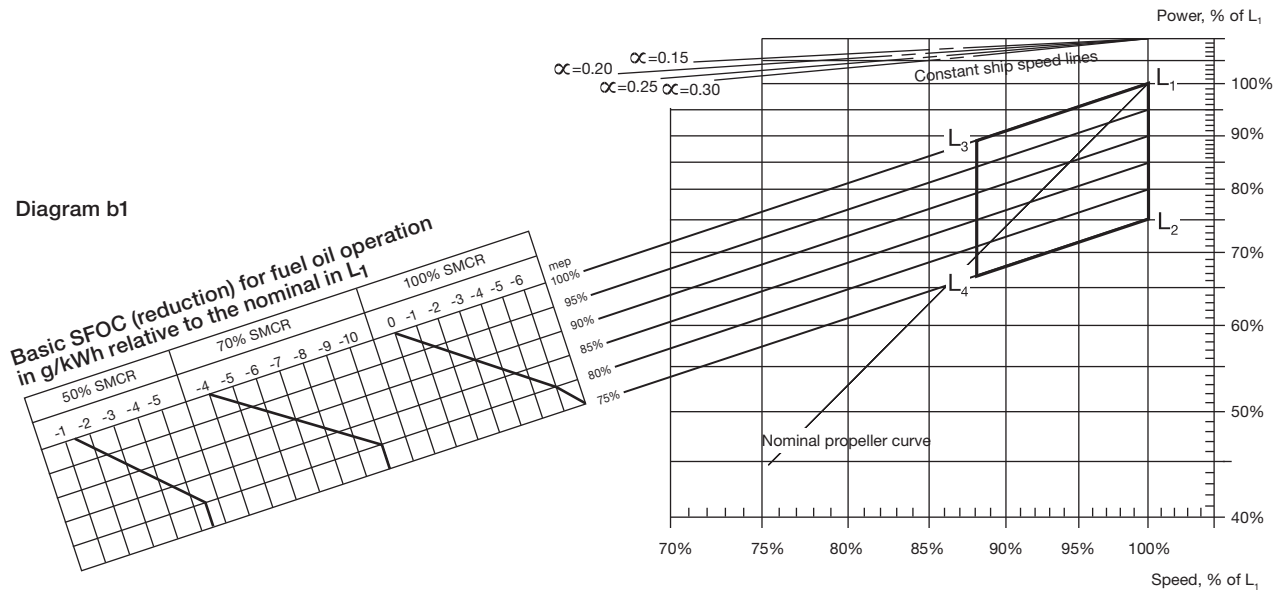

Fig. 2.09.02

178 66 77-8.0

### SFOC for 6G95ME-C9.5-TII with constant speed

Diagram c1

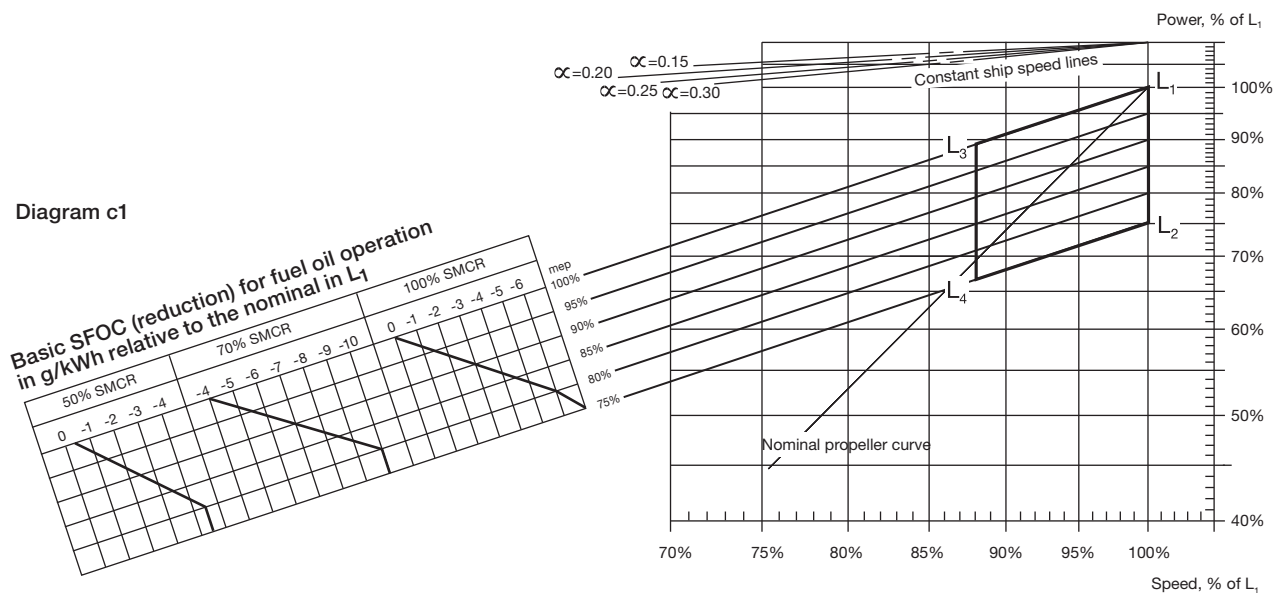

Fig. 2.09.03

178 66 79-1.0

**SFOC calculations, example**

<b>Valid for standard high-load optimised engine</b>	
<b>Data at nominal MCR (L<sub>1</sub>): 6G95ME-C9.5-TII</b>	
Power 100%	41,220 kW
Speed 100%	80 r/min
Nominal SFOC:	
• high efficiency turbocharger	166.0 g/kWh

<b>Example of specified MCR = M</b>	
Power	37,098 kW (90.0% L <sub>1</sub> )
Speed	76.0 r/min (95.0% L <sub>1</sub> )
Turbocharger type	high efficiency
SFOC found in M	164.4 g/kWh

The SMCR point M used in the above example for the SFOC calculations:

M = 90.0% L<sub>1</sub> power and 95.0% L<sub>1</sub> speed



Diagram b1

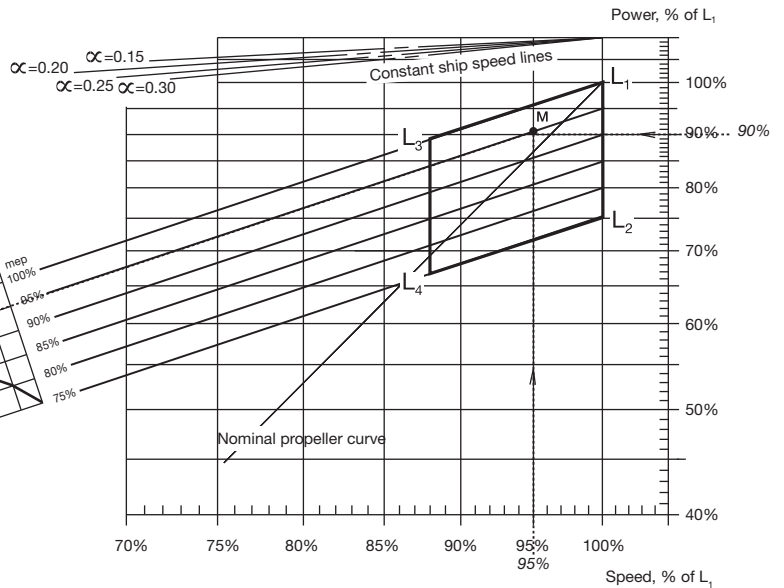
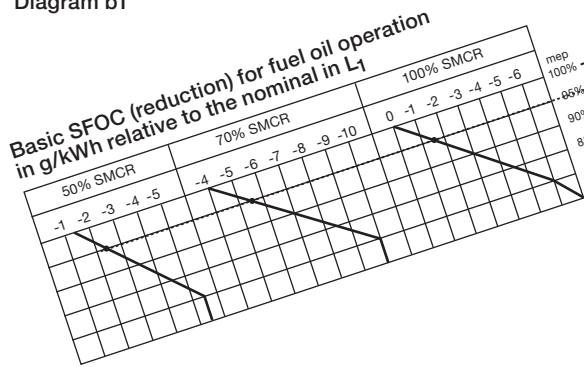

178 66 86-2.0

The reductions, see diagram b, in g/kWh compared to SFOC in L<sub>1</sub>:

Part load points		SFOC g/kWh	SFOC g/kWh
1	100% M	-1.6	164.4
2	70% M	-5.6	160.4
3	50% M	-2.6	163.4

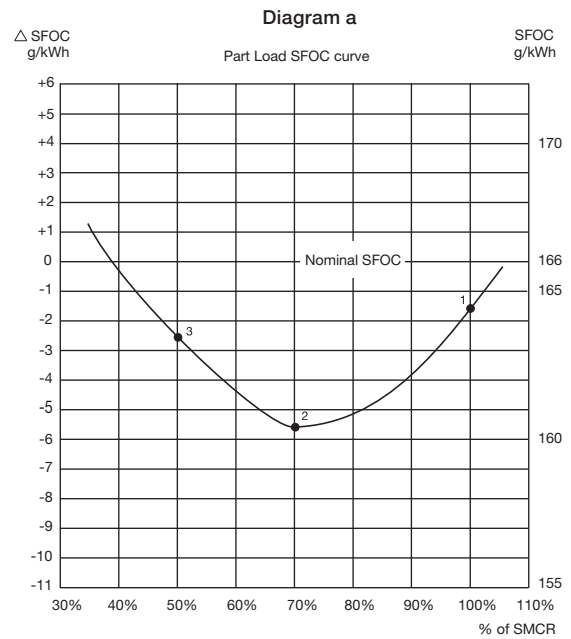

178 64 74-1. 0

Fig. 2.10.01: Example of SFOC for derated 6G95ME-C9.5-TII with fixed pitch propeller and high efficiency turbocharger



### Fuel Consumption at an Arbitrary Load

Once the specified MCR (M) of the engine has been chosen, the specific fuel oil consumption at an arbitrary point  $S_1$ ,  $S_2$  or  $S_3$  can be estimated based on the SFOC at point '1' and '2'.

These SFOC values can be calculated by using the graphs for the relevant engine type for the propeller curve I and for the constant speed curve II, giving the SFOC at points 1 and 2, respectively.

Next the SFOC for point  $S_1$  can be calculated as an interpolation between the SFOC in points '1' and '2', and for point  $S_3$  as an extrapolation.

The SFOC curve through points  $S_2$ , on the left of point 1, is symmetrical about point 1, i.e. at speeds lower than that of point 1, the SFOC will also increase.

The above-mentioned method provides only an approximate value. A more precise indication of the expected SFOC at any load can be calculated by using our computer program. This is a service which is available to our customers on request.

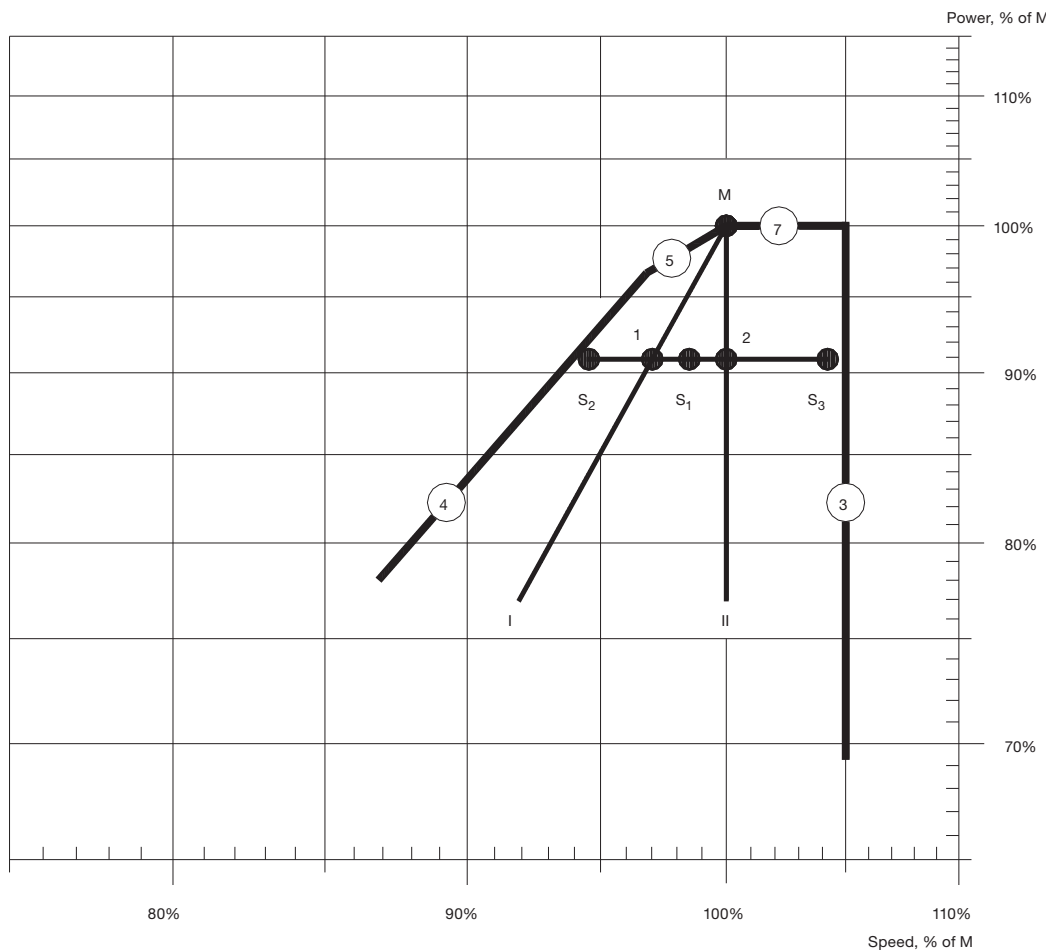

198 95 96-2.2

Fig. 2.11.01: SFOC at an arbitrary load



**MAN B&W**

---

---

# Turbocharger Selection & Exhaust Gas By-pass

**3**

---

---

**MAN Diesel**



## Turbocharger Selection

Updated turbocharger data based on the latest information from the turbocharger makers are available from the Turbocharger Selection program on [www.marine.man.eu](http://www.marine.man.eu) → 'Two-Stroke' → 'Turbocharger Selection'.

The data specified in the printed edition are valid at the time of publishing.

The MC/ME engines are designed for the application of either MAN, ABB or Mitsubishi (MHI) turbochargers.

The turbocharger choice is made with a view to obtaining the lowest possible Specific Fuel Oil Consumption (SFOC) values at the nominal MCR by applying high efficiency turbochargers.

The engines are, as standard, equipped with as few turbochargers as possible, see Table 3.01.01.

One more turbocharger can be applied, than the number stated in the tables, if this is desirable due to space requirements, or for other reasons. Additional costs are to be expected.

However, we recommend the 'Turbocharger Selection' program on the Internet, which can be used to identify a list of applicable turbochargers for a specific engine layout.

For information about turbocharger arrangement and cleaning systems, see Section 15.01.

High efficiency turbochargers for the G95ME-C9.5 engines - L <sub>1</sub> output			
Cyl.	MAN (TCA)	ABB (A100)	MHI (MET)
5	2 x TCA77-21	2 x A275-L	2 x MET71MB
6	2 x TCA88-21	2 x A280-L	2 x MET83MB
7	2 x TCA88-21	2 x A185-L37	2 x MET83MB
8	2 x TCA88-26	2 x A285-L	2 x MET90MB
9	3 x TCA88-21	3 x A280-L	3 x MET83MB
10	3 x TCA88-21	3 x A280-L	3 x MET83MB
11	3 x TCA88-21	3 x A285-L	3 x MET90MB
12	3 x TCA88-26	3 x A285-L	3 x MET90MB

Table 3.01.01: High efficiency turbochargers



## Climate Conditions and Exhaust Gas Bypass

### Extreme ambient conditions

As mentioned in Chapter 1, the engine power figures are valid for tropical conditions at sea level: 45 °C air at 1,000 mbar and 32 °C seawater, whereas the reference fuel consumption is given at ISO conditions: 25 °C air at 1,000 mbar and 25 °C charge air coolant temperature.

Marine diesel engines are, however, exposed to greatly varying climatic temperatures winter and summer in arctic as well as tropical areas. These variations cause changes of the scavenge air pressure, the maximum combustion pressure, the exhaust gas amount and temperatures as well as the specific fuel oil consumption.

For further information about the possible countermeasures, please refer to our publication titled:

*Influence of Ambient Temperature Conditions*

The publication is available at [www.marine.man.eu](http://www.marine.man.eu) → 'Two-Stroke' → 'Technical Papers'.

### Arctic running condition

For air inlet temperatures below -10 °C the precautions to be taken depend very much on the operating profile of the vessel. The following alternative is one of the possible countermeasures. The selection of countermeasures, however, must be evaluated in each individual case.

### Exhaust gas receiver with variable bypass

Option: 4 60 118

Compensation for low ambient temperature can be obtained by using exhaust gas bypass system.

This arrangement ensures that only part of the exhaust gas goes via the turbine of the turbo-charger, thus supplying less energy to the compressor which, in turn, reduces the air supply to the engine.

Please note that if an exhaust gas bypass is applied, the turbocharger size and specification has to be determined by other means than stated in this Chapter.



## Emission Control

### IMO Tier II NO<sub>x</sub> emission limits

All ME, ME-B and ME-C/-GI engines are, as standard, fulfilling the IMO Tier II NO<sub>x</sub> emission requirements, a speed dependent NO<sub>x</sub> limit measured according to ISO 8178 Test Cycles E2/E3 for Heavy Duty Diesel Engines.

The E2/E3 test cycles are referred to in the Extent of Delivery as EoD: 4 06 200 Economy mode with the options: 4 06 201 Engine test cycle E3 or 4 06 202 Engine test cycle E2.

### NO<sub>x</sub> reduction methods for IMO Tier III

As adopted by IMO for future enforcement, the engine must fulfil the more restrictive IMO Tier III NO<sub>x</sub> requirements when sailing in a NO<sub>x</sub> Emission Control Area (NO<sub>x</sub> ECA).

The Tier III NO<sub>x</sub> requirements can be met by Exhaust Gas Recirculation (EGR), a method which directly affects the combustion process by lowering the generation of NO<sub>x</sub>.

Alternatively, the required NO<sub>x</sub> level could be met by installing Selective Catalytic Reaction (SCR), an after treatment system that reduces the emission of NO<sub>x</sub> already generated in the combustion process.

Details of MAN Diesel & Turbo's NO<sub>x</sub> reduction methods for IMO Tier III can be found in our publication:

#### *Emission Project Guide*

The publication is available at [www.marine.man.eu](http://www.marine.man.eu) → 'Two-Stroke' → 'Project Guides' → 'Other Guides'.





**MAN B&W**

---

---

# Electricity Production

4

---

---

**MAN Diesel**



## Electricity Production

### Introduction

Next to power for propulsion, electricity production is the largest fuel consumer on board. The electricity is produced by using one or more of the following types of machinery, either running alone or in parallel:

- Auxiliary diesel generating sets
- Main engine driven generators
- Exhaust gas- or steam driven turbo generator utilising exhaust gas waste heat (Thermo Efficiency System)
- Emergency diesel generating sets.

The machinery installed should be selected on the basis of an economic evaluation of first cost, operating costs, and the demand for man-hours for maintenance.

In the following, technical information is given regarding main engine driven generators (PTO), different configurations with exhaust gas and steam driven turbo generators, and the auxiliary diesel generating sets produced by MAN Diesel & Turbo.

### Power Take Off

With a generator coupled to a Power Take Off (PTO) from the main engine, electrical power can be produced based on the main engine's low SFOC/SGC. Several standardised PTO systems are available, see Fig. 4.01.01 and the designations in Fig. 4.01.02:

- PTO/RCF  
(*Power Take Off/Renk Constant Frequency*):  
Generator giving constant frequency, based on mechanical-hydraulic speed control.
- PTO/CFE  
(*Power Take Off/Constant Frequency Electrical*):  
Generator giving constant frequency, based on electrical frequency control.

- PTO/GCR  
(*Power Take Off/Gear Constant Ratio*):  
Generator coupled to a constant ratio step-up gear, used only for engines running at constant speed.

The DMG/CFE (*Direct Mounted Generator/Constant Frequency Electrical*) and the SMG/CFE (*Shaft Mounted Generator/Constant Frequency Electrical*) are special designs within the PTO/CFE group in which the generator is coupled directly to the main engine crankshaft or the intermediate propeller shaft, respectively, without a gear. The electrical output of the generator is controlled by electrical frequency control.

Within each PTO system, several designs are available, depending on the positioning of the gear:

- BW I:  
Gear with a vertical generator mounted onto the fore end of the diesel engine, without any connections to the ship structure.
- BW II:  
A free-standing gear mounted on the tank top and connected to the fore end of the diesel engine, with a vertical or horizontal generator.
- BW III:  
A crankshaft gear mounted onto the fore end of the diesel engine, with a side-mounted generator without any connections to the ship structure.
- BW IV:  
A free-standing step-up gear connected to the intermediate propeller shaft, with a horizontal generator.

The most popular of the gear based alternatives are the BW III/RCF type for plants with a fixed pitch propeller (FPP). The BW III/RCF requires no separate seating in the ship and only little attention from the shipyard with respect to alignment.



Alternative types and layouts of shaft generators		Design	Seating	Total efficiency (%)
PTO/RCF	1a  1b	BW I/RCF	On engine (vertical generator)	88-91
	2a  2b	BW II/RCF	On tank top	88-91
	3a  3b	BW III/RCF	On engine	88-91
	4a  4b	BW IV/RCF	On tank top	88-91
PTO/CFE	5a  5b	DMG/CFE	On engine	84-88
	6a  6b	SMG/CFE	On tank top	89-91
PTO/GCR	7	BW I/GCR	On engine (vertical generator)	92
	8	BW II/GCR	On tank top	92
	9	BW III/GCR	On engine	92
	10	BW IV/GCR	On tank top	92

178 63 68-7.0

Fig. 4.01.01: Types of PTO



### Designation of PTO

For further information, please refer to our publication titled:

*Shaft Generators for MC and ME engines*

The publication is available at [www.marine.man.eu](http://www.marine.man.eu) → 'Two-Stroke' → 'Technical Papers'.

### Power take off:

BW III S90ME-C8/RCF 700-60

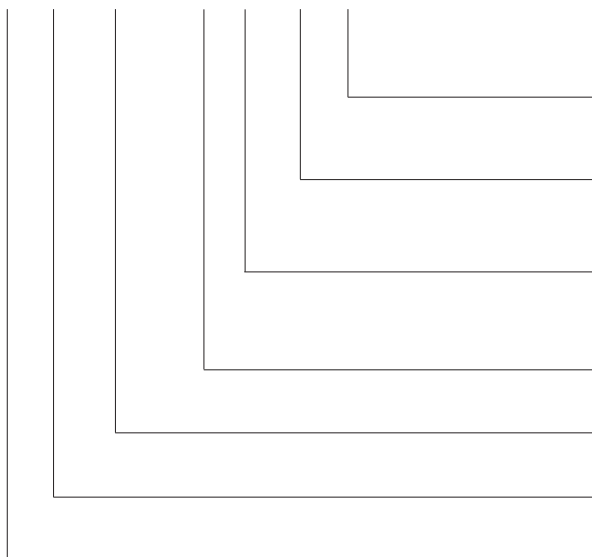

50: 50 Hz  
60: 60 Hz

kW on generator terminals

RCF: Renk constant frequency unit  
CFE: Electrically frequency controlled unit

Mark version

Engine type on which it is applied

Layout of PTO: See Fig. 4.01.01

Make: MAN Diesel & Turbo/Renk

178 39 55-6.0

Fig. 4.01.02: Example of designation of PTO



## PTO/RCF

Side mounted generator, BW III/RCF  
(Fig. 4.01.01, Alternative 3)

The PTO/RCF generator systems have been developed in close cooperation with the German gear manufacturer RENK. A complete package solution is offered, comprising a flexible coupling, a step-up gear, an epicyclic, variable-ratio gear with built-in clutch, hydraulic pump and motor, and a standard generator, see Fig. 4.01.04.

For marine engines with controllable pitch propellers running at constant engine speed, the hydraulic system can normally be omitted. For constant speed engines a PTO/GCR design is normally used.

Fig. 4.01.04 shows the principles of the PTO/RCF arrangement. As can be seen, a step-up gear box (called crankshaft gear) with three gear wheels is bolted directly to front- and part side engine crankcase structure. The bearings of the three gear wheels are mounted in the gear box so that the weight of the wheels is not carried by the crankshaft. Between the crankcase and the gear drive, space is available for tuning wheel, counterweights, axial vibration damper, etc.

The first gear wheel is connected to the crankshaft via a special flexible coupling, made in one piece with a tooth coupling driving the crankshaft gear, thus isolating the gear drive against torsional and axial vibrations.

By means of a simple arrangement, the shaft in the crankshaft gear carrying the first gear wheel and the female part of the toothed coupling can be moved forward, thus disconnecting the two parts of the toothed coupling.

The power from the crankshaft gear is transferred, via a multi-disc clutch, to an epicyclic variable-ratio gear and the generator. These are mounted on a common PTO bedplate, bolted to brackets integrated with the engine crankcase structure.

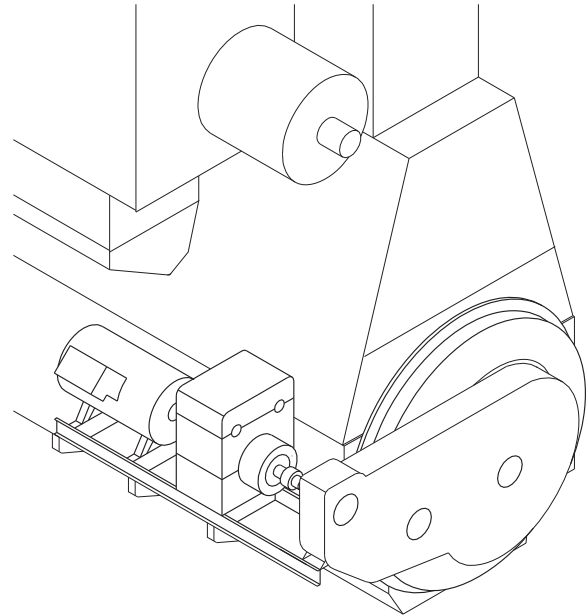

178 06 49-0.0

Fig. 4.01.03: Side mounted BW III/RCF

The BW III/RCF unit is an epicyclic gear with a hydrostatic superposition drive. The hydrostatic input drives the annulus of the epicyclic gear in either direction of rotation, hence continuously varying the gearing ratio to keep the generator speed constant throughout an engine speed variation of 30%. In the standard layout, this is between 100% and 70% of the engine speed at specified MCR, but it can be placed in a lower range if required.

The input power to the gear is divided into two paths – one mechanical and the other hydrostatic – and the epicyclic differential combines the power of the two paths and transmits the combined power to the output shaft, connected to the generator. The gear is equipped with a hydrostatic motor driven by a pump, and controlled by an electronic control unit. This keeps the generator speed constant during single running as well as when running in parallel with other generators.



The multi-disc clutch, integrated into the gear input shaft, permits the engaging and disengaging of the epicyclic gear, and thus the generator, from the main engine during operation.

An electronic control system with a RENK controller ensures that the control signals to the main electrical switchboard are identical to those for the normal auxiliary generator sets. This applies to ships with automatic synchronising and load sharing, as well as to ships with manual switchboard operation.

Internal control circuits and interlocking functions between the epicyclic gear and the electronic control box provide automatic control of the functions necessary for the reliable operation and protection of the BW III/RCF unit. If any monitored value exceeds the normal operation limits, a warning or an alarm is given depending upon the origin, severity and the extent of deviation from the permissible values. The cause of a warning or an alarm is shown on a digital display.

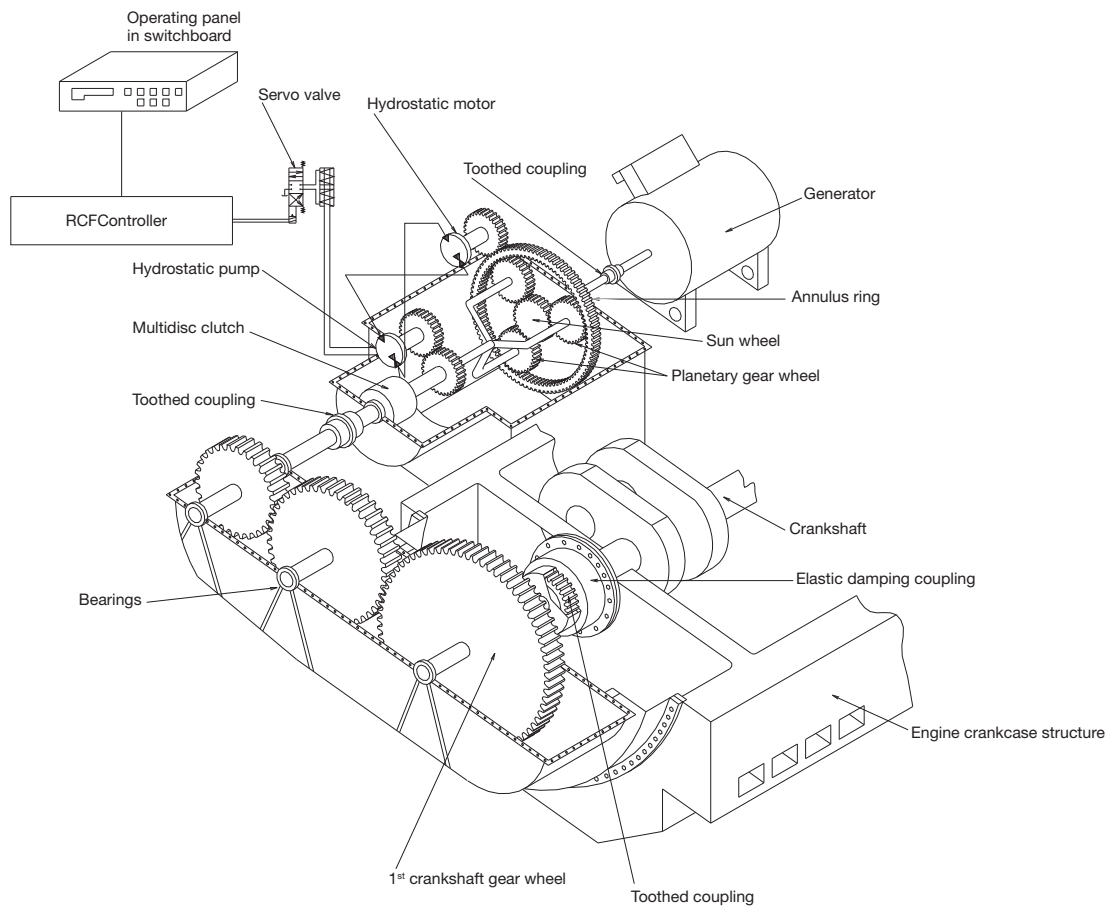

178 23 22-2.2

Fig. 4.01.04: Power take off with RENK constant frequency gear: BW III/RCF, option: 4 85 253

**Extent of delivery for BW III/RCF units**

The delivery comprises a complete unit ready to be built-on to the main engine. Fig. 4.02.01 shows the required space and the standard electrical output range on the generator terminals.

Standard sizes of the crankshaft gears and the RCF units are designed for: 700, 1200, 1800 and 2600 kW, while the generator sizes of make A. van Kaick are:

Type DSG	440 V 1800 kVA	60 Hz r/min kW	380 V 1500 kVA	50 Hz r/min kW
62 M2-4	707	566	627	501
62 L1-4	855	684	761	609
62 L2-4	1,056	845	940	752
74 M1-4	1,271	1,017	1,137	909
74 M2-4	1,432	1,146	1,280	1,024
74 L1-4	1,651	1,321	1,468	1,174
74 L2-4	1,924	1,539	1,709	1,368
86 K1-4	1,942	1,554	1,844	1,475
86 M1-4	2,345	1,876	2,148	1,718
86 L2-4	2,792	2,234	2,542	2,033
99 K1-4	3,222	2,578	2,989	2,391

178 34 89-3.1

In the event that a larger generator is required, please contact MAN Diesel & Turbo.

If a main engine speed other than the nominal is required as a basis for the PTO operation, it must be taken into consideration when determining the ratio of the crankshaft gear. However, it has no influence on the space required for the gears and the generator.

The PTO can be operated as a motor (PTI) as well as a generator by making some minor modifications.

Yard deliveries are:

1. Cooling water pipes to the built-on lubricating oil cooling system, including the valves.
2. Electrical power supply to the lubricating oil stand-by pump built on to the RCF unit.
3. Wiring between the generator and the operator control panel in the switchboard.
4. An external permanent lubricating oil filling-up connection can be established in connection with the RCF unit. The system is shown in Fig. 4.03.03 'Lubricating oil system for RCF gear'. The dosage tank and the pertaining piping are to be delivered by the yard. The size of the dosage tank is stated in the table for RCF gear in 'Necessary capacities for PTO/RCF' (Fig. 4.03.02).

The necessary preparations to be made on the engine are specified in Figs. 4.03.01a and 4.03.01b.

**Additional capacities required for BW III/RCF**

The capacities stated in the 'List of capacities' for the main engine in question are to be increased by the additional capacities for the crankshaft gear and the RCF gear stated in Fig. 4.03.02.

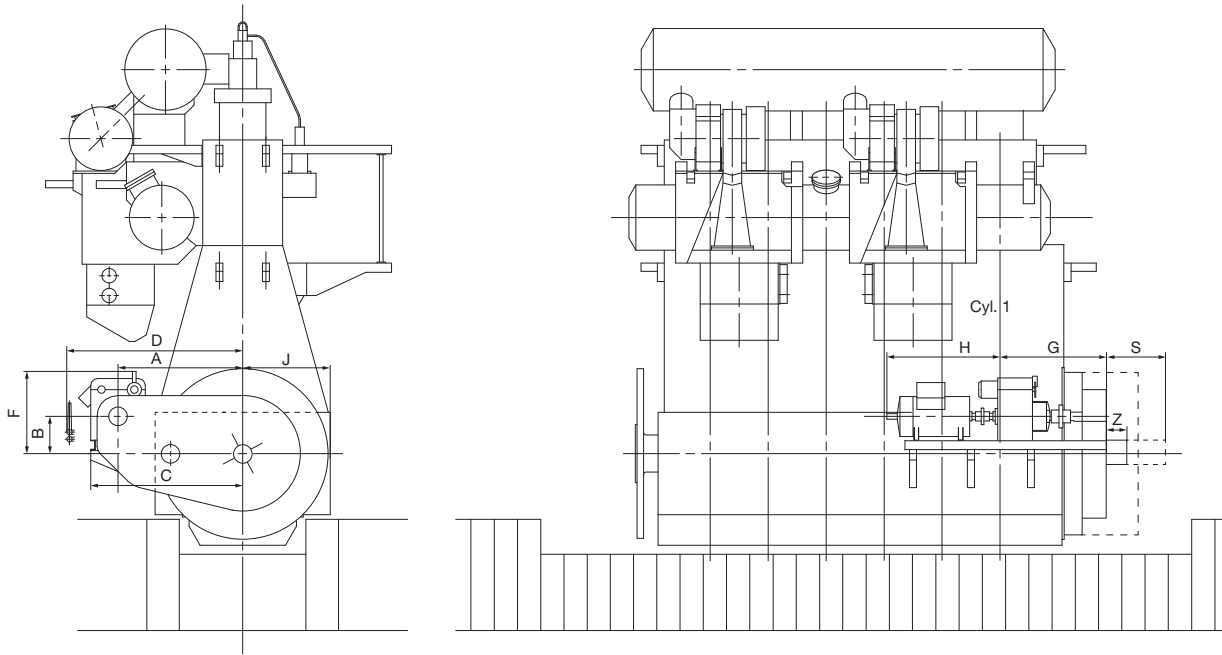

178 65 39-0.1

kW generator				
	700 kW	1,200 kW	1,800 kW	2,600 kW
A	3,490	3,490	3,630	3,630
B	750	750	750	750
C	4,150	4,150	4,410	4,410
D	4,540	4,540	4,820	4,820
F	1,890	1,890	2,130	2,240
G	2,980	2,980	3,380	3,380
H	1,700	2,200	2,540	3,860
J	2,690			
S	1,500	1,500	1,500	1,500
Z	500	500	500	500
<b>System mass (kg) with generator:</b>				
	31,750	36,500	49,600	66,550
<b>System mass (kg) without generator:</b>				
	29,750	33,850	45,300	61,350

The stated kW at the generator terminals is available between 70% and 100% of the engine speed at specified MCR

Space requirements have to be investigated case by case on plants with 2,600 kW generator.

Dimension H: This is only valid for A. van Kaick generator type DSG, enclosure IP23, frequency = 60 Hz, speed = 1,800 r/min

Fig. 4.02.01: Space requirement for side mounted generator PTO/RCF type BWIII G95-C/RCF





Engine preparations for PTO

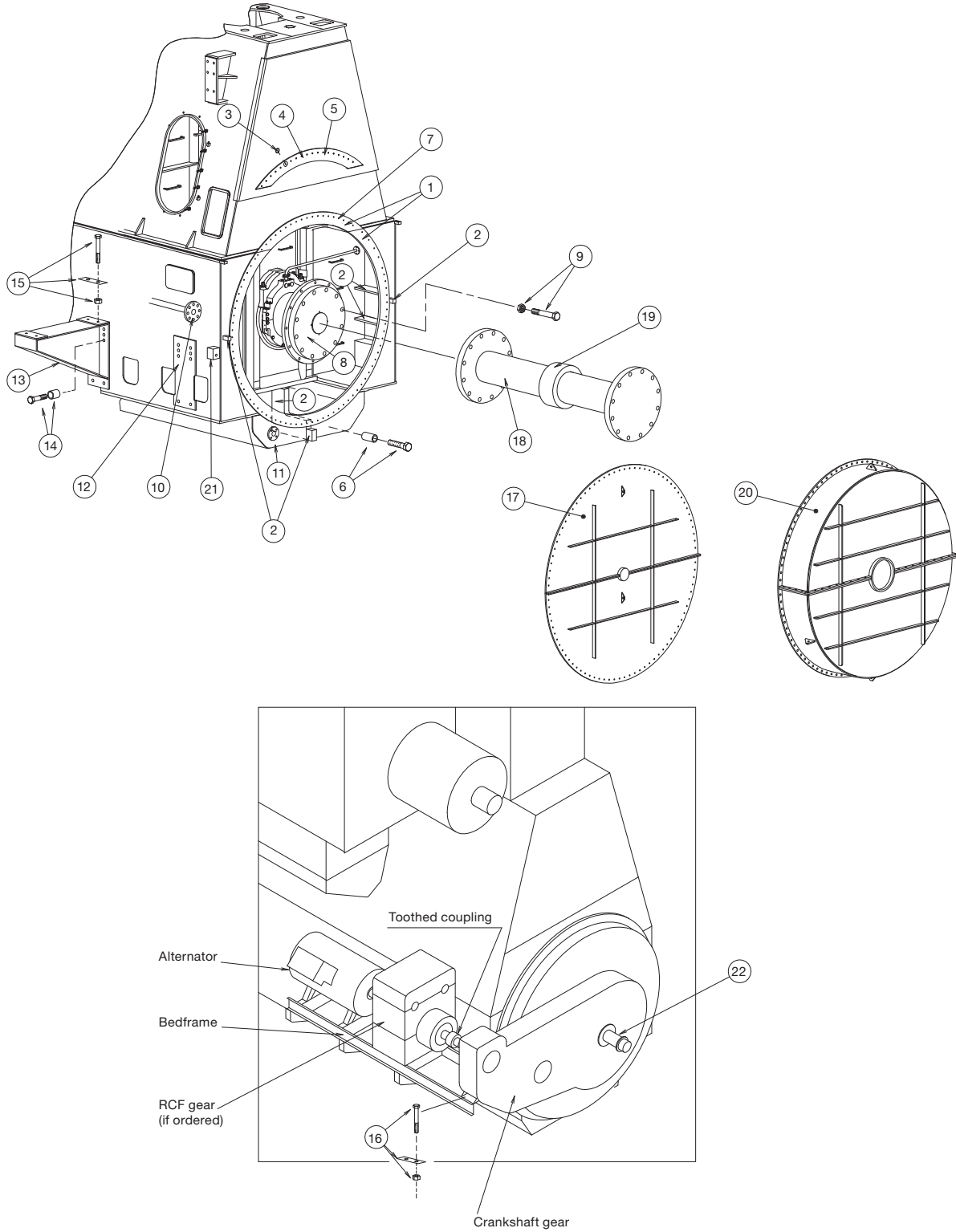

Fig. 4.03.01a: Engine preparations for PTO, BWIII/RCF system

178 57 15-7.1



Pos.

- 1 Special face on bedplate and frame box
- 2 Ribs and brackets for supporting the face and machined blocks for alignment of gear or stator housing
- 3 Machined washers placed on frame box part of face to ensure that it is flush with the face on the bedplate
- 4 Rubber gasket placed on frame box part of face
- 5 Shim placed on frame box part of face to ensure that it is flush with the face of the bedplate
- 6 Distance tubes and long bolts
- 7 Threaded hole size, number and size of spring pins and bolts to be made in agreement with PTO maker
- 8 Flange of crankshaft, normally the standard execution can be used
- 9 Studs and nuts for crankshaft flange
- 10 Free flange end at lubricating oil inlet pipe (incl. blank flange)
- 11 Oil outlet flange welded to bedplate (incl. blank flange)
- 12 Face for brackets
- 13 Brackets
- 14 Studs for mounting the brackets
- 15 Studs, nuts and shims for mounting of RCF-/generator unit on the brackets
- 16 Shims, studs and nuts for connection between crankshaft gear and RCF-/generator unit
- 17 Engine cover with connecting bolts to bedplate/frame box to be used for shop test without PTO
- 18 Intermediate shaft between crankshaft and PTO
- 19 Oil sealing for intermediate shaft
- 20 Engine cover with hole for intermediate shaft and connecting bolts to bedplate/frame box
- 21 Plug box for electronic measuring instrument for checking condition of axial vibration damper
- 22 Tacho encoder for ME control system or MAN B&W Alpha lubrication system on MC engine
- 23 Tacho trigger ring for ME control system or MAN B&W Alpha lubrication system on MC engine

Pos. no:	1	2	3	4	5	6	7	8	9	10	11	12	13	14	15	16	17	18	19	20	21	22	23
BWIII/RCF	A	A	A	A		B		A	B	A	A	A	A	A	B	B	A				A	A	
BWIII/CFE	A	A	A	A		B		A	B	A	A	A	A	A	B	B	A				A	A	
BWII/RCF								A	A									A	A	A	A		A
BWII/CFE								A	A									A	A	A	A		A
BWI/RCF	A	A	A	A		B		A	B								A				A		A
BWI/CFE	A	A	A	A		B		A	B	A	A						A				A		A
DMG/CFE	A	A			A	B	C	A	B								A				A		A

A: Preparations to be carried out by engine builder  
 B: Parts supplied by PTO maker  
 C: See text of pos. no.

178 89 34-2.0

Table 4.03.01b: Engine preparations for PTO



**Crankshaft gear** lubricated from the main engine lubricating oil system

The figures are to be added to the main engine capacity list:

Nominal output of generator	kW	700	1,200	1,800	2,600
Lubricating oil flow	m <sup>3</sup> /h	4.1	4.1	4.9	6.2
Heat dissipation	kW	12.1	20.8	31.1	45.0

**RCF gear** with separate lubricating oil system:

Nominal output of generator	kW	700	1,200	1,800	2,600
Cooling water quantity	m <sup>3</sup> /h	14.1	22.1	30.0	39.0
Heat dissipation	kW	55	92	134	180
El. power for oil pump	kW	11.0	15.0	18.0	21.0
Dosage tank capacity	m <sup>3</sup>	0.40	0.51	0.69	0.95
El. power for Renk controller	24V DC ± 10%, 8 amp				

From main engine:

Design lube oil pressure: 2.25 bar

Lube oil pressure at crankshaft gear: min. 1 bar

Lube oil working temperature: 50 °C

Lube oil type: SAE 30

Cooling water inlet temperature: 36 °C

Pressure drop across cooler: approximately 0.5 bar

Fill pipe for lube oil system store tank (~ø32)

Drain pipe to lube oil system drain tank (~ø40)

Electric cable between Renk terminal at gearbox and operator control panel in switchboard: Cable type FMGCG 19 x 2 x 0.5

178 33 85-0.0

Table 4.03.02: Necessary capacities for PTO/RCF, BW III/RCF system

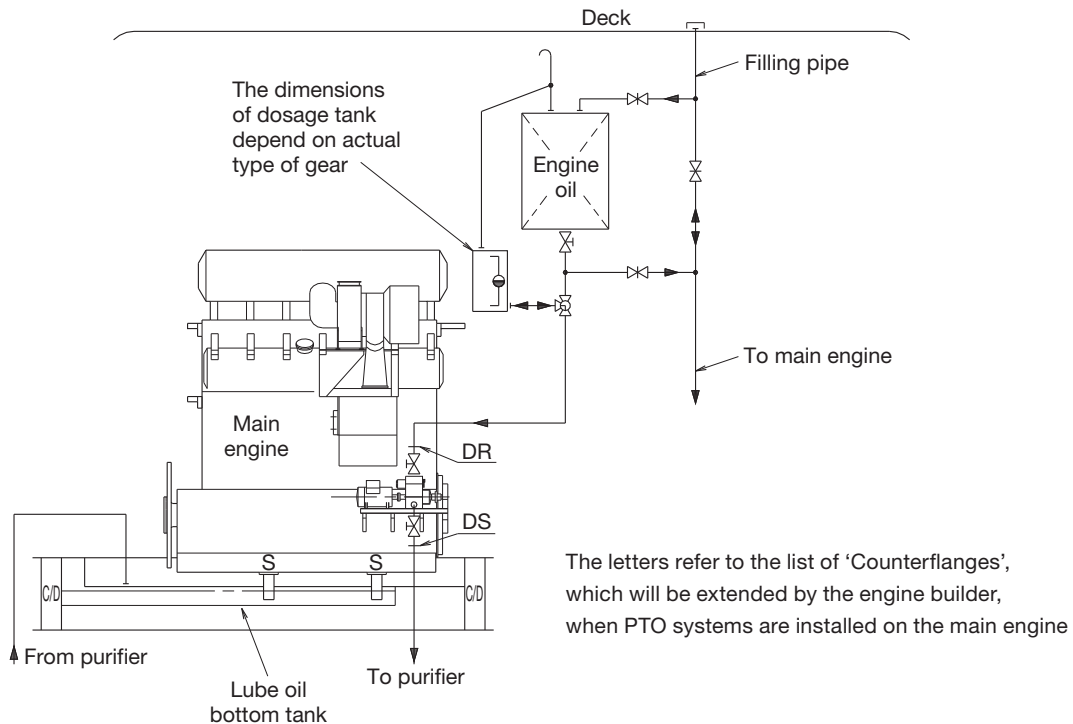

178 25 23-5.0

Fig. 4.03.03: Lubricating oil system for RCF gear



**DMG/CFE Generators**  
**Option: 4 85 259**

Fig. 4.01.01 alternative 5, shows the DMG/CFE (Direct Mounted Generator/Constant Frequency Electrical) which is a low speed generator with its rotor mounted directly on the crankshaft and its stator bolted on to the frame box as shown in Figs. 4.03.04 and 4.03.05.

The DMG/CFE is separated from the crankcase by a plate and a labyrinth stuffing box.

The DMG/CFE system has been developed in cooperation with the German generator manufacturers Siemens and AEG, but similar types of generator can be supplied by others, e.g. Fuji, Taiyo and Nishishiba in Japan.

For generators in the normal output range, the mass of the rotor can normally be carried by the foremost main bearing without exceeding the permissible bearing load (see Fig. 4.03.05), but this must be checked by the engine manufacturer in each case.

If the permissible load on the foremost main bearing is exceeded, e.g. because a tuning wheel is needed, this does not preclude the use of a DMG/CFE.

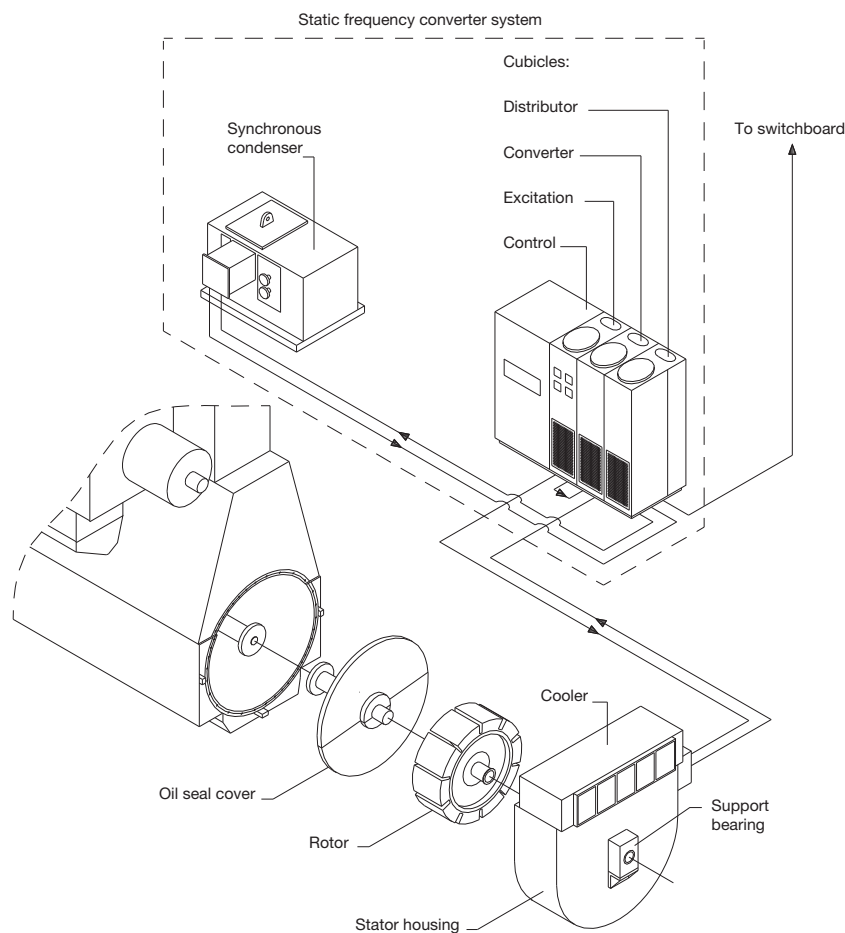

178 06 73-3.1

Fig. 4.03.04: Standard engine, with direct mounted generator (DMG/CFE)

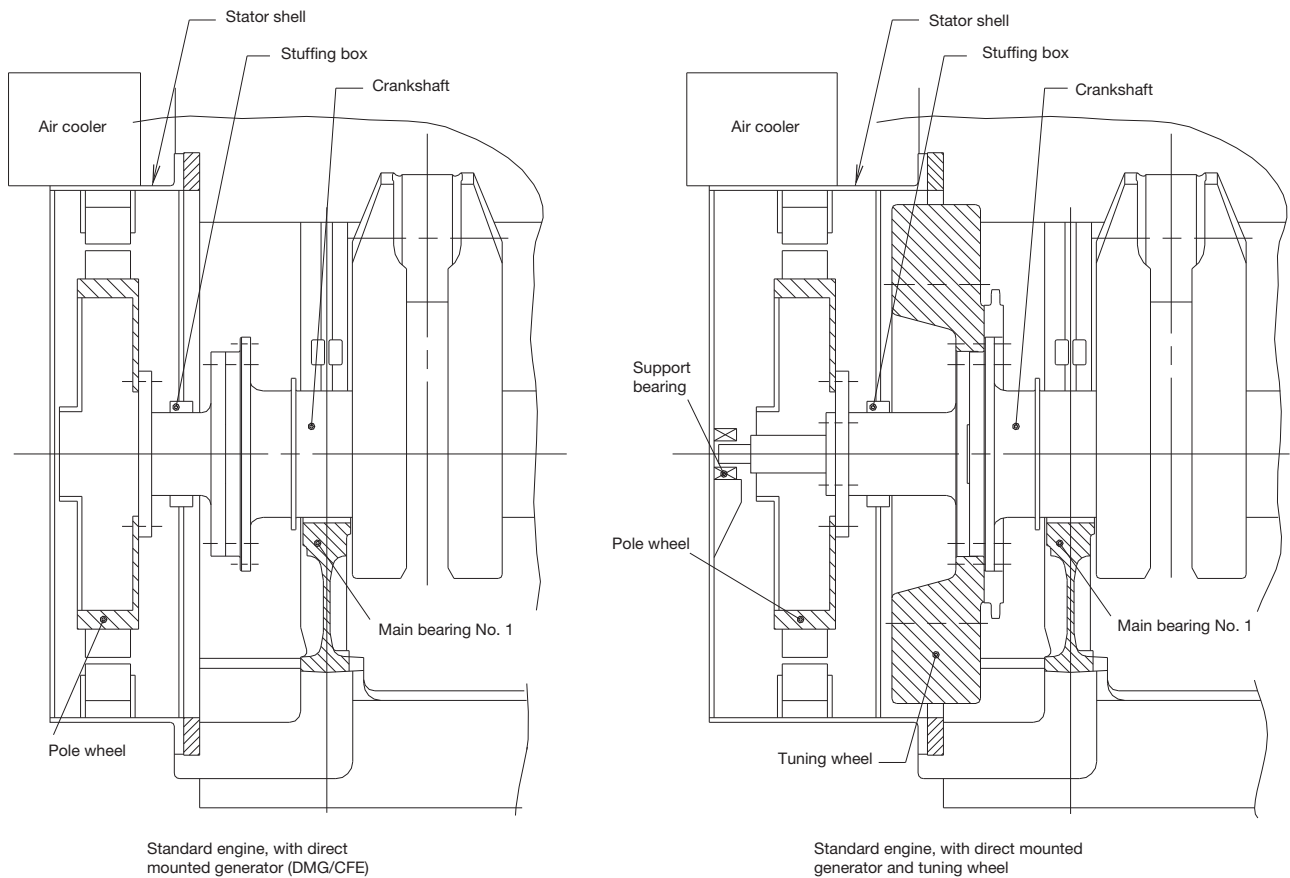

178 06 63-7.1

Fig. 4.03.05: Standard engine, with direct mounted generator and tuning wheel

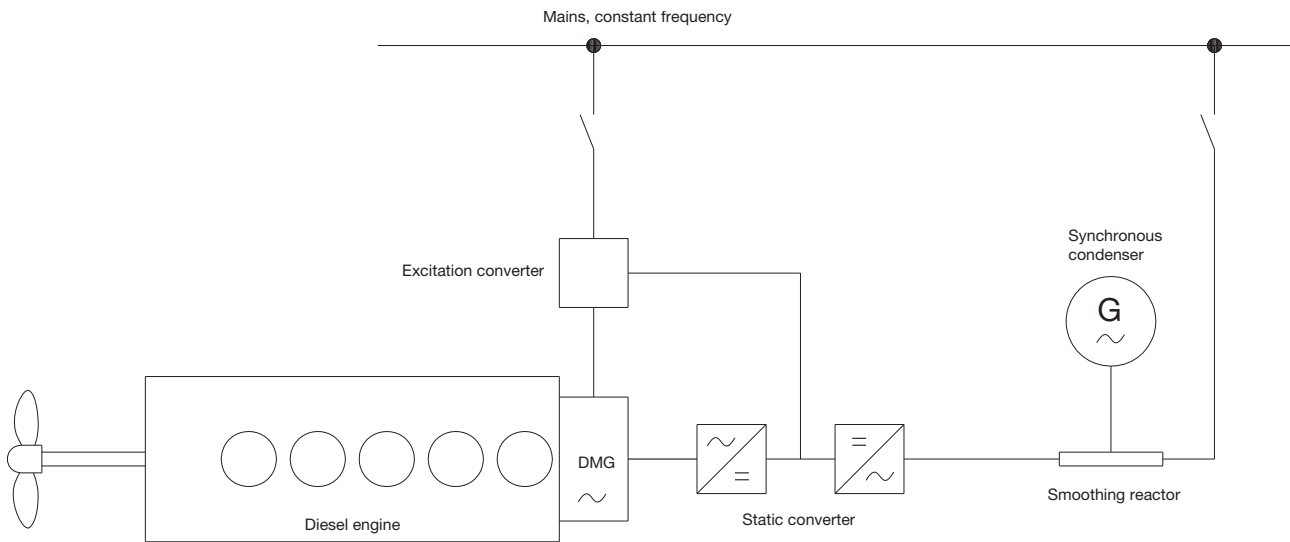

178 56 55-3.1

Fig. 4.03.06: Diagram of DMG/CFE with static converter



In such a case, the problem is solved by installing a small, elastically supported bearing in front of the stator housing, as shown in Fig. 4.03.05.

As the DMG type is directly connected to the crankshaft, it has a very low rotational speed and, consequently, the electric output current has a low frequency – normally of the order of 15 Hz.

Therefore, it is necessary to use a static frequency converter between the DMG and the main switchboard. The DMG/CFE is, as standard, laid out for operation with full output between 100% and 75% and with reduced output between 75% and 40% of the engine speed at specified MCR.

### Static converter

The static frequency converter system (see Fig. 4.03.06) consists of a static part, i.e. thyristors and control equipment, and a rotary electric machine.

The DMG produces a three-phase alternating current with a low frequency, which varies in accordance with the main engine speed. This alternating current is rectified and led to a thyristor inverter producing a three-phase alternating current with constant frequency.

Since the frequency converter system uses a DC intermediate link, no reactive power can be supplied to the electric mains. To supply this reactive power, a synchronous condenser is used. The synchronous condenser consists of an ordinary synchronous generator coupled to the electric mains.

### Extent of delivery for DMG/CFE units

The delivery extent is a generator fully built-on to the main engine including the synchronous condenser unit and the static converter cubicles which are to be installed in the engine room.

The DMG/CFE can, with a small modification, be operated both as a generator and as a motor (PTI).

Yard deliveries are:

1. Installation, i.e. seating in the ship for the synchronous condenser unit and for the static converter cubicles
2. Cooling water pipes to the generator if water cooling is applied
3. Cabling.

The necessary preparations to be made on the engine are specified in Fig. 4.03.01a and Table 4.03.01b.

### SMG/CFE Generators

The PTO SMG/CFE (see Fig. 4.01.01 alternative 6) has the same working principle as the PTO DMG/CFE, but instead of being located on the front end of the engine, the alternator is installed aft of the engine, with the rotor integrated on the intermediate shaft.

In addition to the yard deliveries mentioned for the PTO DMG/CFE, the shipyard must also provide the foundation for the stator housing in the case of the PTO SMG/CFE.

The engine needs no preparation for the installation of this PTO system.



**PTO BW/GCR**

**This section is not applicable**



## Waste Heat Recovery Systems (WHRS)

Due to the increasing fuel prices seen from 2004 and onwards many shipowners have shown interest in efficiency improvements of the power systems on board their ships. A modern two-stroke diesel engine has one of the highest thermal efficiencies of today's power systems, but even this high efficiency can be improved by combining the diesel engine with other power systems.

One of the possibilities for improving the efficiency is to install one or more systems utilising some of the energy in the exhaust gas after the two-stroke engine, which in MAN Diesel & Turbo terms is designated as WHRS (Waste Heat Recovery Systems).

WHRS can be divided into different types of sub-systems, depending on how the system utilises the exhaust gas energy. Choosing the right system for a specific project depends on the electricity demand on board the ship and the acceptable first cost for the complete installation. MAN Diesel & Turbo uses the following designations for the current systems on the market:

- **PTG (Power Turbine Generator):**  
An exhaust gas driven turbine connected to a generator via a gearbox.
- **STG (Steam Turbine Generator):**  
A steam driven turbine connected to a generator via a gearbox. The steam is produced in a large exhaust gas driven boiler installed on the main engine exhaust gas piping system.
- **Combined Turbines:**  
A combination of the two first systems. The arrangement is often that the power turbine is connected to the steam turbine via a gearbox and the steam turbine is further connected to a large generator, which absorbs the power from both turbines.

The PTG system will produce power equivalent to approx. 3.5% of the main engine SMCR, when the engine is running at SMCR. For the STG system this value is between 5 and 7% depending on the system installed. When combining the two systems, a power output equivalent to 10% of the main engine's SMCR is possible, when the engine is running at SMCR.

The WHRS output depends on the main engine rating and whether service steam consumption must be deducted or not.

As the electrical power produced by the system needs to be used on board the ship, specifying the correct size system for a specific project must be considered carefully. In cases where the electrical power consumption on board the ship is low, a smaller system than possible for the engine type may be considered. Another possibility is to install a shaft generator/motor to absorb excess power produced by the WHRS. The main engine will then be unloaded, or it will be possible to increase the speed of the ship, without penalising the fuel bill.

Because the energy from WHRS is taken from the exhaust gas of the main engine, this power produced can be considered as "free". In reality, the main engine SFOC will increase slightly, but the gain in electricity production on board the ship will far surpass this increase in SFOC. As an example, the SFOC of the combined output of both the engine and the system with power and steam turbine can be calculated to be as low as 152 g/kWh (ref. LCV 42,700 kJ/kg).





### Power Turbine Generator (PTG)

The power turbines of today are based on the different turbocharger suppliers' newest designs of high efficiency turbochargers, i.e. MAN TCA, ABB A-L and Mitsubishi MET turbochargers.

MAN Diesel & Turbo offers PTG solutions called TCS-PTG in the range from approx. 1,000 kW to 5,000 kW, see Fig. 4.05.02.

The power turbine basically is the turbine side of a normal high-efficient turbocharger with some modifications to the bearings and the turbine shaft. This is in order to be able to connect it to a gearbox instead of the normal connection to the compressor side. The power turbine will be installed on a separate exhaust gas pipe from the exhaust gas receiver, which bypasses the turbochargers.

The performance of the PTG and the main engine will depend on a careful matching of the engine turbochargers and the power turbine, for which reason the turbocharger/s and the power turbine need to be from the same manufacturer. In Fig. 4.05.01, a diagram of the PTG arrangement is shown.

The newest generation of high efficiency turbochargers allows bypassing of some of the main engine exhaust gas, thereby creating a new balance of the air flow through the engine. In this way, it is possible to extract power from the power turbine equivalent to 3.5% of the main engine's SMCR, when the engine is running at SMCR.

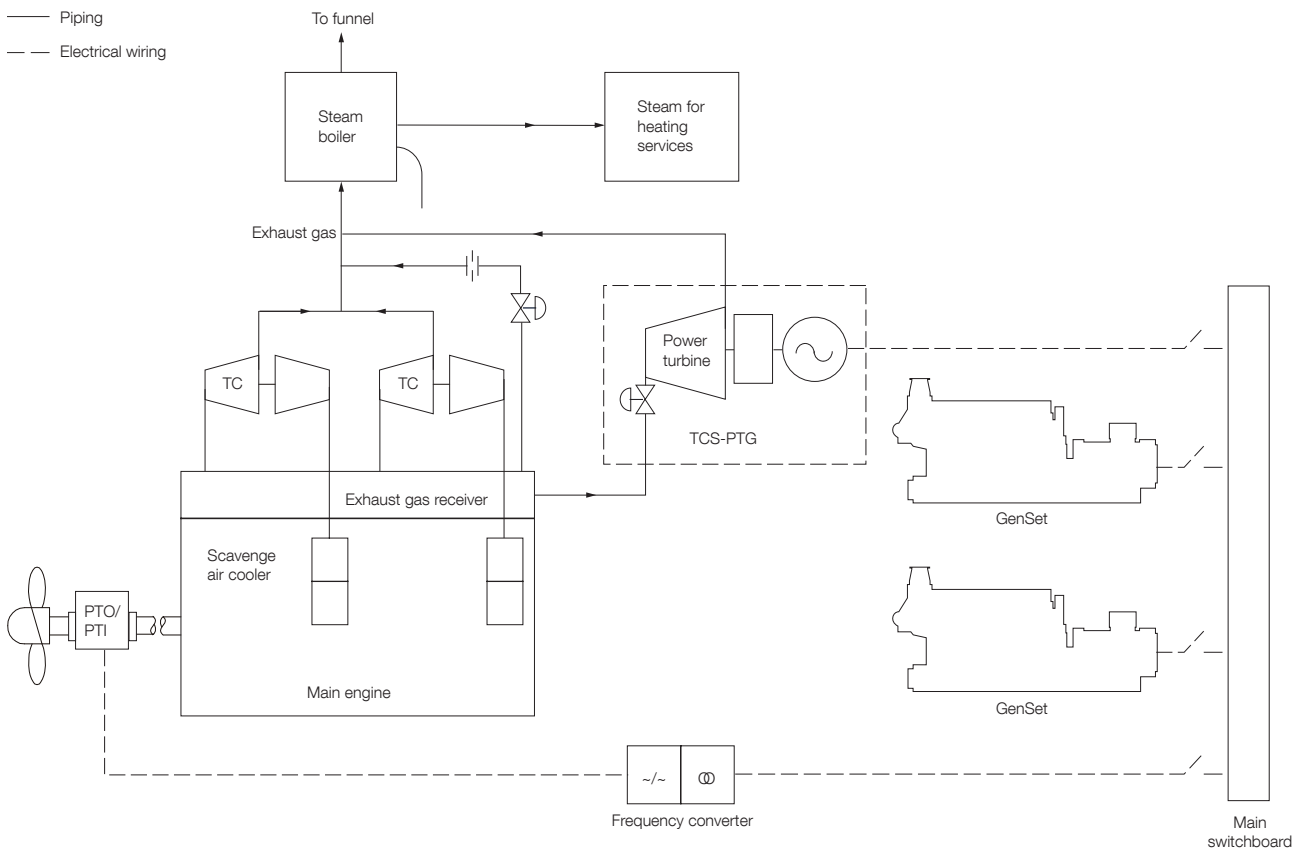

178 63 80-5.0

Fig. 4.05.01: PTG diagram

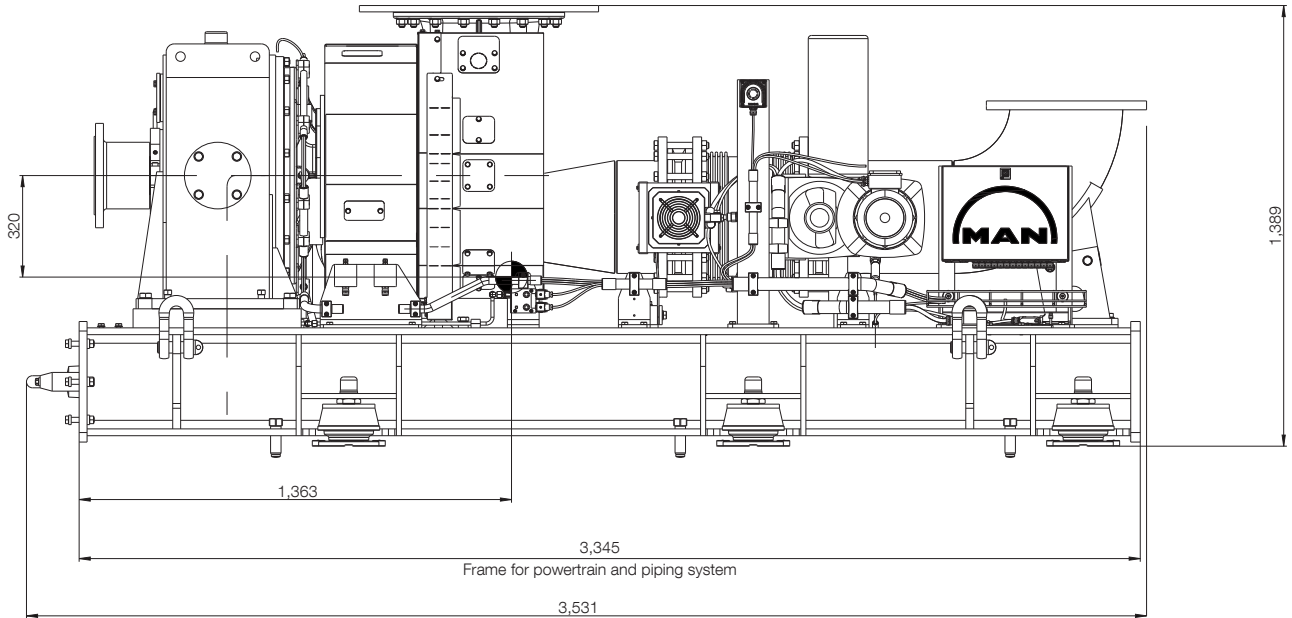

178 63 81-7.0

Fig. 4.05.02: MAN Diesel & Turbo 1,500 kW TCS-PTG solution



### Steam Turbine Generator (STG)

In most cases the exhaust gas pipe system of the main engine is equipped with a boiler system. With this boiler, some of the energy in the exhaust gas is utilised to produce steam for use on board the ship.

If the engine is WHR matched, the exhaust gas temperature will be between 50°C and 65°C higher than on a conventional engine, which makes it possible to install a larger boiler system and, thereby, produce more steam. In short, MAN Diesel & Turbo designates this system STG. Fig. 4.05.03 shows an example of the STG diagram.

For WHR matching the engine, a bypass is installed to increase the temperature of the exhaust gas and improve the boiler output. The bypass valve is controlled by the engine control system.

The extra steam produced in the boiler can be utilised in a steam turbine, which can be used to drive a generator for power production on board the ship. A STG system could be arranged as shown in Fig. 4.05.04, where a typical system size is shown with the outline dimensions.

The steam turbine can either be a single or dual pressure turbine, depending on the size of the system. Steam pressure for a single pressure system is 7 to 10 bara, and for the dual pressure system the high-pressure cycle will be 9 to 10 bara and the low-pressure cycle will be 4 to 5 bara.

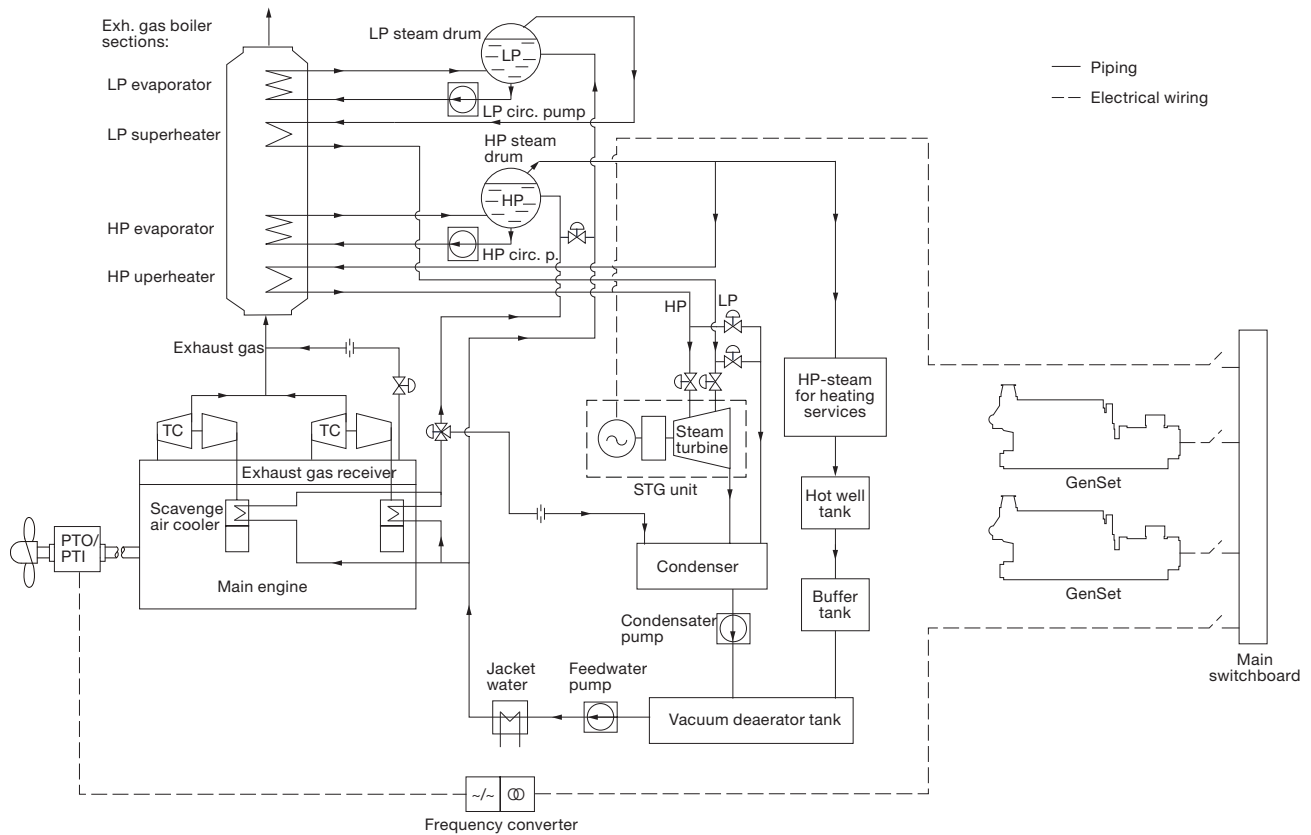

178 63 82-9.0

Fig. 4.05.03: STG system diagram

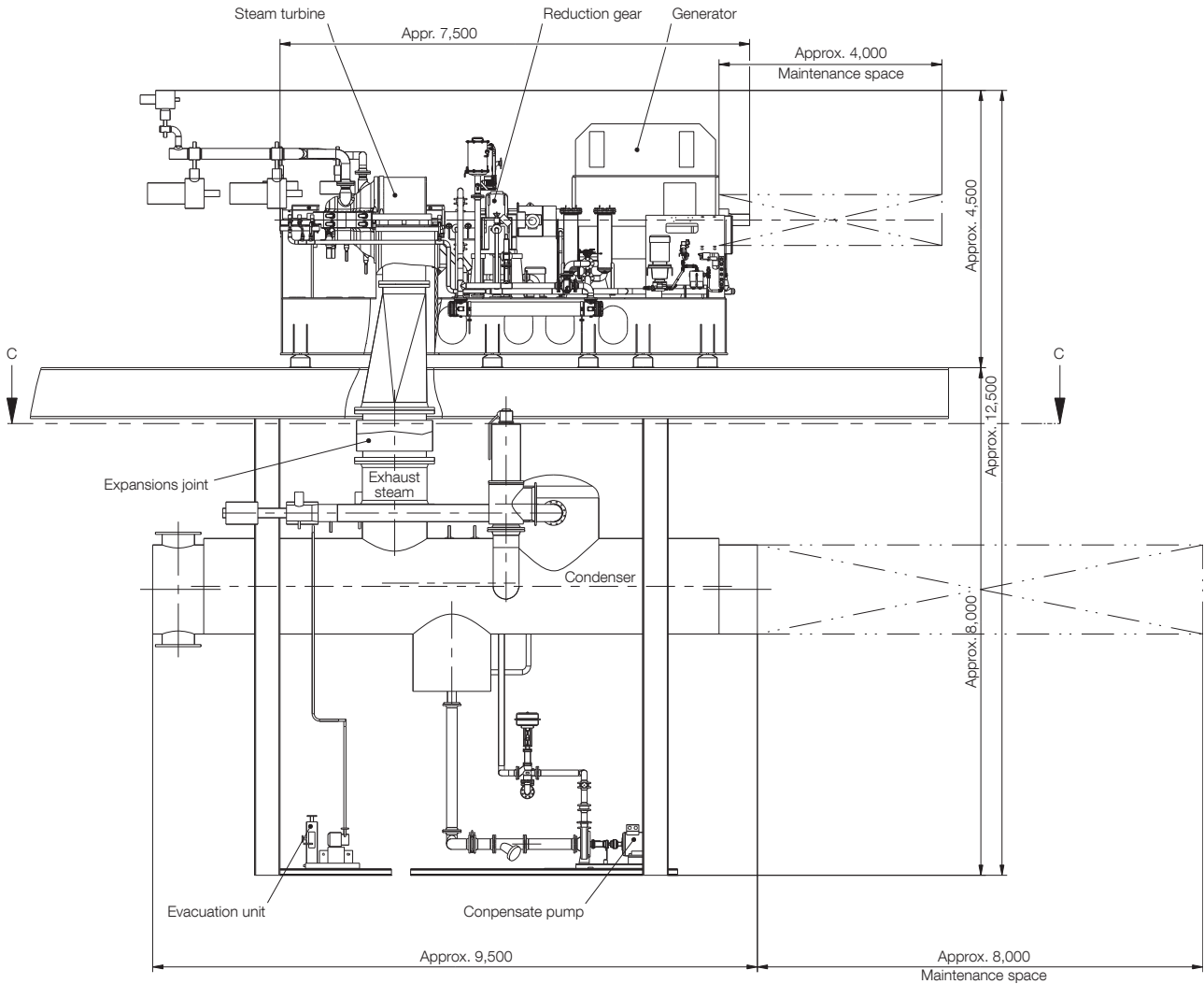

178 63 83-0.1

Fig. 4.05.04: STG steam turbine generator arrangement with condenser - typical arrangement



### Full WHRS Steam and Power Turbines Combined

Because the installation of the power turbine also will result in an increase of the exhaust gas temperature after the turbochargers, it is possible to install both the power turbine, the larger boiler and steam turbine on the same engine. This way, the energy from the exhaust gas is utilised in the best way possible by today's components.

When looking at the system with both power and steam turbine, quite often the power turbine and the steam turbine are connected to the same generator. In some cases, it is also possible to have each turbine on a separate generator. This is, however, mostly seen on stationary engines, where the frequency control is simpler because of the large grid to which the generator is coupled.

For marine installations the power turbine is, in most cases, connected to the steam turbine via a

gearbox, and the steam turbine is then connected to the generator. It is also possible to have a generator with connections in both ends, and then connect the power turbine in one end and the steam turbine in the other. In both cases control of one generator only is needed.

For dimensions of a typical full WHRS see Fig. 4.05.06.

As mentioned, the systems with steam turbines require a larger boiler to be installed. The size of the boiler system will be considerably bigger than the size of an ordinary boiler system, and the actual boiler size has to be calculated from case to case. Casing space for the exhaust boiler must be reserved in the initial planning of the ship's machinery spaces.

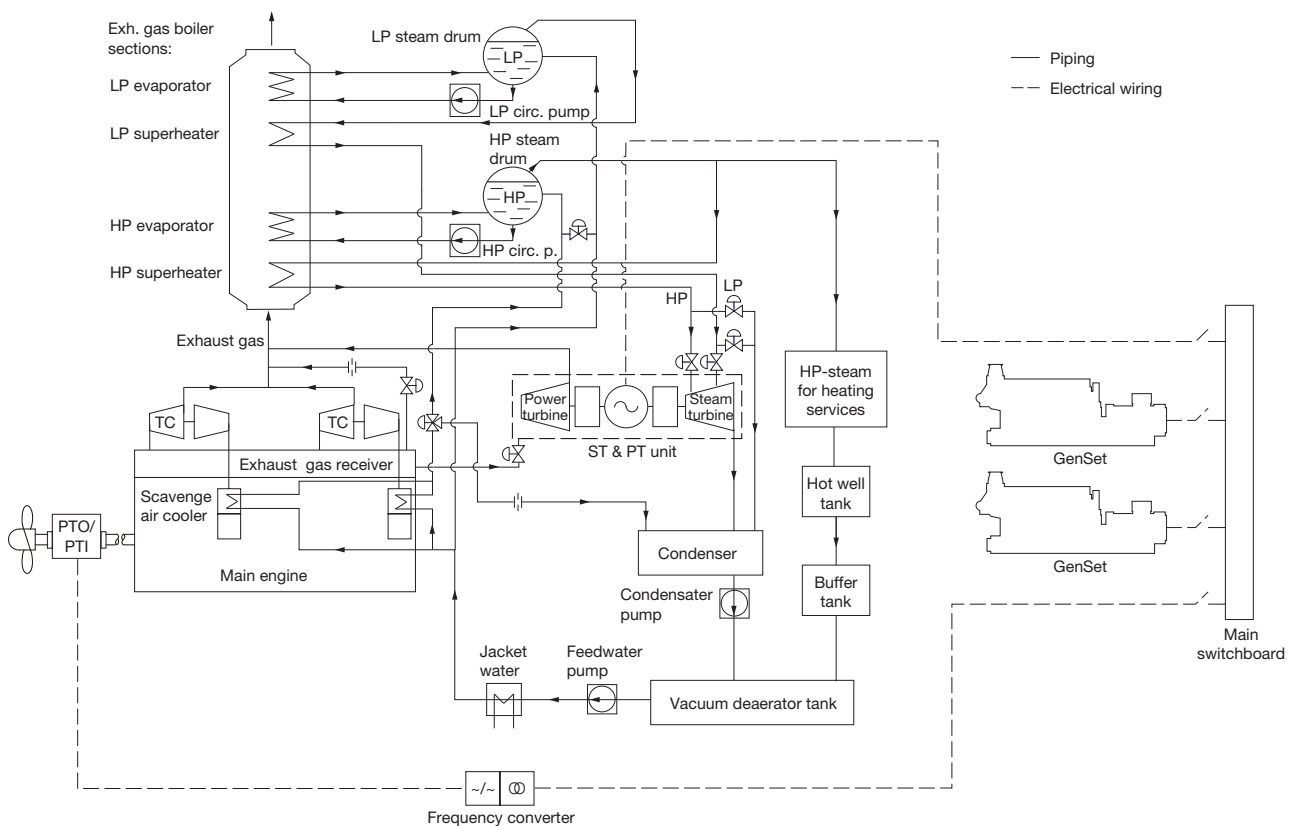
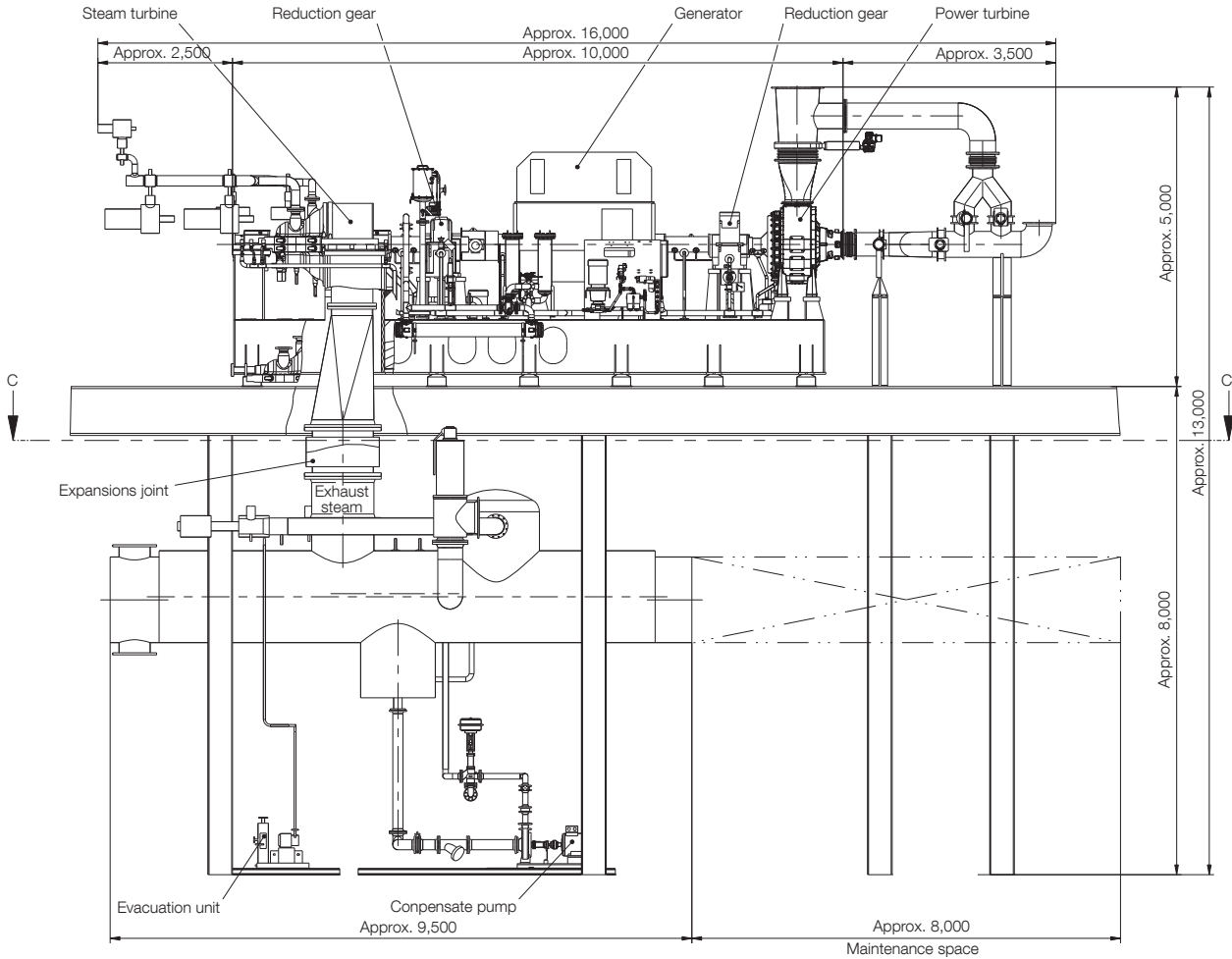

Fig. 4.05.05: Full WHRS with both steam and power turbines

178 63 84-2.0



178 63 85-4.1

Fig. 4.05.06: Full ST & PT full waste heat recovery unit arrangement with condenser - typical arrangement



## WHRS generator output

Because all the components come from different manufacturers, the final output and the system efficiency have to be calculated from case to case.

However, Table 4.05.07 shows a guidance of possible outputs in  $L_1$  based on theoretically calculated outputs from the system.

### WHRS output at a rating lower than $L_1$

As engines are seldom rated in  $L_1$ , it is recommended to contact MAN Diesel & Turbo Copenhagen, department Marine Installation, e-mail: lee4@mandieselturbo.com for specific WHRS generator output.

In order to receive as correctly as possible an engine tuned for WHRS data, please specify requested engine rating (power × rpm) and ship service steam consumption (kg/hour).

Detailed information about the different WHRS systems is found in our publication:

*Waste Heat Recovery System (WHRS)*

The publication is available at [www.marine.man.eu](http://www.marine.man.eu) → 'Two-Stroke' → 'Technical Papers'.

Guidance output of WHR for G95ME-C9/-GI-TII engine rated in $L_1$ at ISO conditions					
Cyl.	Engine power		PTG	STG	Full WHRS with combined turbines
	% SMCR	kW	kWe	kWe	kWe
5	100	34,350	1,243	1,718	2,824
	75	25,763	790	1,292	1,879
6	100	41,220	1,500	2,201	3,405
	75	30,915	965	1,566	2,271
7	100	48,090	1,760	2,587	3,991
	75	36,068	1,145	1,847	2,669
8	100	54,960	2,023	2,979	4,584
	75	41,220	1,330	2,132	3,072
9	100	61,830	2,300	3,376	5,181
	75	46,373	1,610	2,431	3,523
10	100	68,700	2,583	3,779	5,840
	75	51,525	1,808	2,721	3,971
11	100	75,570	2,872	4,187	6,952
	75	56,678	2,010	3,014	4,728
12	100	82,440	3,166	4,600	7,749
	75	61,830	2,216	3,312	5,270

Note 1: The above given preliminary WHRS generator outputs is based on HP service steam consumption of 0.3 ton/h and LP service steam consumption of 0.7 ton/h for the ship at ISO condition.

Note 2: 75% SMCR is selected due to the EEDI focus on the engine load.

Table 4.05.07: Theoretically calculated outputs



### Waste Heat Recovery Element and Safety Valve

The boiler water or steam for power generator is preheated in the Waste Heat Recovery (WHR) element, also called the first-stage air cooler.

The WHR element is typically built as a high-pressure water/steam heat exchanger which is placed on top of the scavenge air cooler, see Fig. 4.05.08.

Full water flow must be passed through the WHR element continuously when the engine is running. This must be considered in the layout of the steam feed water system (the WHR element supply heating). Refer to our 'WHR element specification' which is available from MAN Diesel & Turbo, Copenhagen.

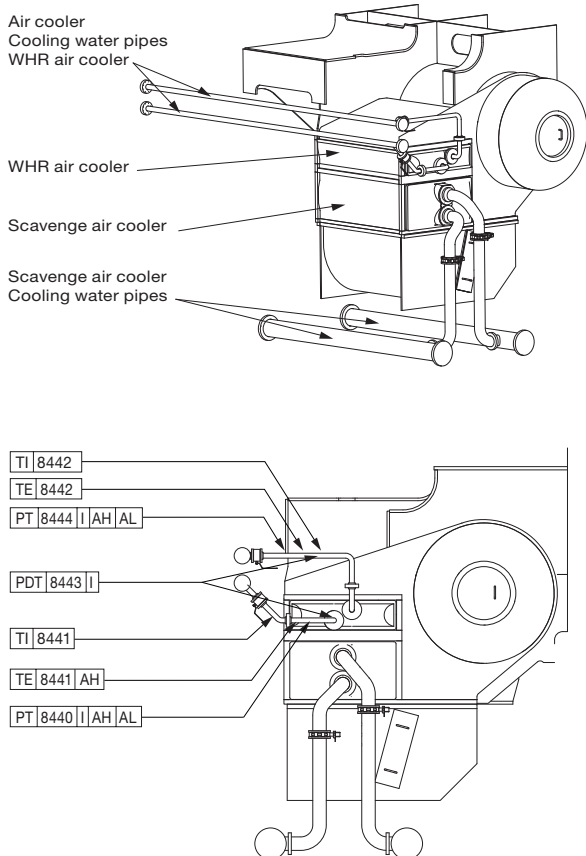

521 39 06-2.1.1

Fig. 4.05.08: WHR element on Scavenge air cooler

### Safety valve and blow-off

In normal operation, the temperature and pressure of the WHR element is in the range of 140-150 °C and 8-21 bar respectively.

In order to prevent leaking components from causing personal injuries or damage to vital parts of the main engine, a safety relief valve will blow off excess pressure. The safety relief valve is connected to an external connection, 'W', see Fig. 4.05.09.

Connection 'W' must be passed to the funnel or another free space according to the class rules for steam discharge from safety valve.

As the system is pressurised according to class rules, the safety valve must be type approved.

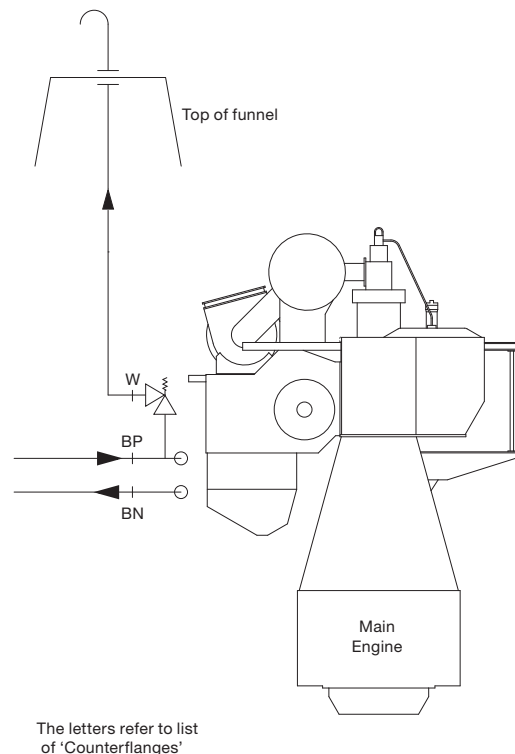

078 63 84-0.0.1

Fig. 4.05.09: WHR safety valve blow-off through connection 'W' to the funnel





**GenSet Data**

**This section is not applicable**



L27/38-TII GenSet Data

Bore: 270 mm

Stroke: 380 mm

	Power layout					
	720 r/min	60 Hz	750 r/min	50 Hz	720/750 r/min (MGO/MDO)	60/50 Hz (MGO/MDO)
	Eng. kW	Gen. kW	Eng. kW	Gen. kW	Eng. kW	Gen. kW
5L27/38	1,500	1,440	1,600	1,536	-	-
6L27/38	1,980	1,900	1,980	1,900	2,100	2,016
7L27/38	2,310	2,218	2,310	2,218	2,450	2,352
8L27/38	2,640	2,534	2,640	2,534	2,800	2,688
9L27/38	2,970	2,851	2,970	2,851	3,150	3,024

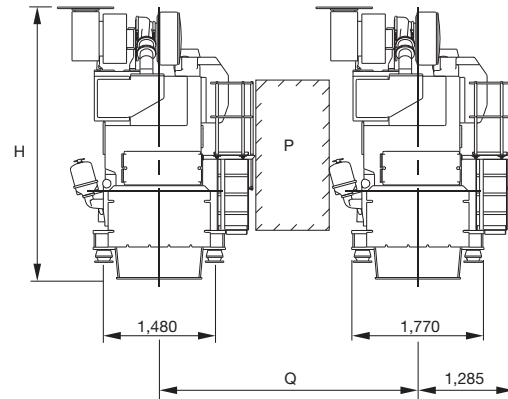
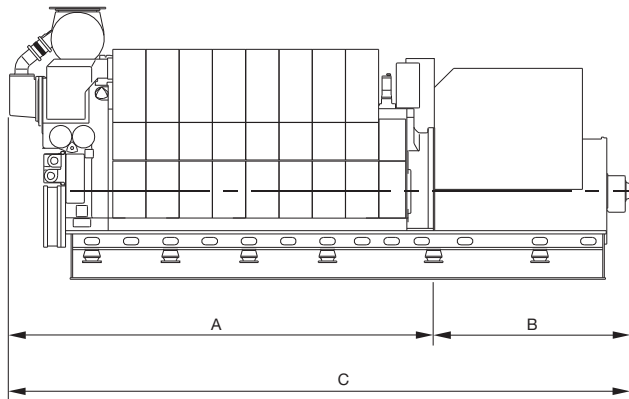

178 23 07-9.1

No. of Cyls.	A (mm)	* B (mm)	* C (mm)	H (mm)	**Dry weight GenSet (t)
5 (720 r/min)	4,346	2,486	6,832	3,712	42.3
5 (750 r/min)	4,346	2,486	6,832	3,712	42.3
6 (720 r/min)	4,791	2,766	7,557	3,712	45.8
6 (750 r/min)	4,791	2,766	7,557	3,712	46.1
7 (720 r/min)	5,236	2,766	8,002	3,899	52.1
7 (750 r/min)	5,236	2,766	8,002	3,899	52.1
8 (720 r/min)	5,681	2,986	8,667	3,899	56.3
8 (750 r/min)	5,681	2,986	8,667	3,899	58.3
9 (720 r/min)	6,126	2,986	9,112	3,899	63.9
9 (750 r/min)	6,126	2,986	9,112	3,899	63.9

P Free passage between the engines, width 600 mm and height 2,000 mm  
 Q Min. distance between engines: 2,900 mm (without gallery) and 3,100 mm (with gallery)  
 \* Depending on alternator  
 \*\* Weight includes a standard alternator  
 All dimensions and masses are approximate and subject to change without prior notice.

178 33 89-8.3

Fig. 4.09.01: Power and outline of L27/38, IMO Tier II

**L27/38-TII GenSet Data**

6-9L27/38: 350 kW/cyl., 720 rpm, MGO

**Reference Condition: Tropic**

Air temperature	°C	45
LT-water temperature inlet engine (from system)	°C	38
Air pressure	bar	1
Relative humidity	%	50

**Temperature basis**

Setpoint HT cooling water engine outlet <sup>1)</sup>	°C	79 nominal (Range of mechanical thermostatic element 77 to 85)
Setpoint LT cooling water engine outlet <sup>2)</sup>	°C	35 nominal (Range of mechanical thermostatic element 29 to 41)
Setpoint Lube oil inlet engine	°C	66 nominal (Range of mechanical thermostatic element 63 to 72)

Number of Cylinders	-	6	7	8	9
Engine output	kW	2,100	2,450	2,800	3,150
Speed	rpm		720		

**Heat to be dissipated <sup>3)</sup>**

Cooling water (C.W.) Cylinder	kW	315	368	421	473
Charge air cooler; cooling water HT	kW	668	784	903	1,022
Charge air cooler; cooling water LT	kW	175	200	224	247
Lube oil (L.O.) cooler	kW	282	329	376	423
Heat radiation engine	kW	70	81	93	104

**Flow rates <sup>4)</sup>**

Internal (inside engine)					
HT circuit (cylinder + charge air cooler HT stage)	m <sup>3</sup> /h	58	58	58	58
LT circuit (lube oil + charge air cooler LT stage)	m <sup>3</sup> /h	58	58	58	58
Lube oil	m <sup>3</sup> /h	64	92	92	92
External (from engine to system)					
HT water flow (at 40°C inlet)	m <sup>3</sup> /h	21.5	24.8	28.1	31.4
LT water flow (at 38°C inlet)	m <sup>3</sup> /h	58	58	58	58

**Air data**

Temperature of charge air at charge air cooler outlet	°C	50	53	55	56
Air flow rate	m <sup>3</sup> /h <sup>5)</sup>	12,792	14,924	17,056	19,188
	kg/kWh	6.67	6.67	6.67	6.67
Charge air pressure	bar			4.01	
Air required to dissipate heat radiation (engine) (t <sub>2</sub> -t <sub>1</sub> = 10°C)	m <sup>3</sup> /h	22,682	26,247	30,135	33,699

**Exhaust gas data <sup>6)</sup>**

Volume flow (temperature turbocharger outlet)	m <sup>3</sup> /h <sup>7)</sup>	27,381	31,944	36,508	41,071
Mass flow	t/h	14.4	16.8	19.2	21.6
Temperature at turbine outlet	°C	388	388	388	388
Heat content (190°C)	kW	857	1,000	1,143	1,285
Permissible exhaust back pressure	mbar			< 30	

**Pumps**

a) Engine driven pumps					
HT circuit cooling water	(2.5 bar)	m <sup>3</sup> /h	58	58	58
LT circuit cooling water	(2.5 bar)	m <sup>3</sup> /h	58	58	58
Lube oil (4.5 bar)		m <sup>3</sup> /h	64	92	92
b) External pumps <sup>8)</sup>					
Diesel oil pump	(5 bar at fuel oil inlet A1)	m <sup>3</sup> /h	1.48	1.73	1.98
Fuel oil supply pump	(4 bar discharge pressure)	m <sup>3</sup> /h	0.71	0.83	0.95
Fuel oil circulating pump	(8 bar at fuel oil inlet A1)	m <sup>3</sup> /h	1.48	1.73	1.98

**Starting air data**

Air consumption per start, incl. air for jet assist (IR/TDI)	Nm <sup>3</sup>	2.9	3.3	3.8	4.3
--	-----------------	-----	-----	-----	-----

- 1) LT cooling water flow first through LT stage charge air cooler, then through lube oil cooler, water temperature outlet engine regulated by mechanical thermostat.
- 2) HT cooling water flow first through HT stage charge air cooler, then through water jacket and cylinder head, water temperature outlet engine regulated by mechanical thermostat.
- 3) Tolerance: + 10% for rating coolers, - 15% for heat recovery.

- 4) Basic values for layout of the coolers.
- 5) Under above mentioned reference conditions.
- 6) Tolerance: quantity +/- 5%, temperature +/- 20°C.
- 7) Under below mentioned temperature at turbine outlet and pressure according above mentioned reference conditions.
- 8) Tolerance of the pumps delivery capacities must be considered by the manufactures.

Fig. 4.09.02a: List of capacities for L27/38, 720 rpm, IMO Tier II



**L27/38-TII GenSet Data**

6-9L27/38: 350 kW/cyl., 750 rpm, MGO

**Reference Condition : Tropic**

Air temperature	°C	45
LT-water temperature inlet engine (from system)	°C	38
Air pressure	bar	1
Relative humidity	%	50

**Temperature basis**

Setpoint HT cooling water engine outlet <sup>1)</sup>	°C	79 nominal (Range of mechanical thermostatic element 77 to 85)
Setpoint LT cooling water engine outlet <sup>2)</sup>	°C	35 nominal (Range of mechanical thermostatic element 29 to 41)
Setpoint Lube oil inlet engine	°C	66 nominal (Range of mechanical thermostatic element 63 to 72)

<b>Number of Cylinders</b>	-	<b>6</b>	<b>7</b>	<b>8</b>	<b>9</b>
Engine output	kW	2,100	2,450	2,800	3,150
Speed	rpm		750		

**Heat to be dissipated <sup>3)</sup>**

Cooling water (C.W.) Cylinder	kW	315	368	421	473
Charge air cooler; cooling water HT	kW	679	797	916	1037
Charge air cooler; cooling water LT	kW	181	208	234	258
Lube oil (L.O.) cooler	kW	282	329	376	423
Heat radiation engine	kW	70	81	93	104

**Flow rates <sup>4)</sup>**

<b>Internal (inside engine)</b>		6	7	8	9
HT circuit (cylinder + charge air cooler HT stage)	m <sup>3</sup> /h	69	69	69	69
LT circuit (lube oil + charge air cooler LT stage)	m <sup>3</sup> /h	69	69	69	69
Lube oil	m <sup>3</sup> /h	66	96	96	96
<b>External (from engine to system)</b>		6	7	8	9
HT water flow (at 40°C inlet)	m <sup>3</sup> /h	21.9	25.4	28.9	32.2
LT water flow (at 38°C inlet)	m <sup>3</sup> /h	69	69	69	69

**Air data**

Temperature of charge air at charge air cooler outlet	°C	55	55	55	55
Air flow rate	m <sup>3</sup> /h <sup>5)</sup>	13,003	15,170	17,338	19,505
	kg/kWh	6.78	6.78	6.78	6.78
Charge air pressure	bar		4.09		
Air required to dissipate heat radiation (engine) (t <sub>2</sub> -t <sub>1</sub> =10°C)	m <sup>3</sup> /h	22,682	26,247	30,135	33,699

**Exhaust gas data <sup>6)</sup>**

Volume flow (temperature turbocharger outlet)	m <sup>3</sup> /h <sup>7)</sup>	27,567	32,161	36,756	41,350
Mass flow	t/h	14.7	17.1	19.5	22.0
Temperature at turbine outlet	°C	382	382	382	382
Heat content (190°C)	kW	844	985	1,126	1,266
Permissible exhaust back pressure	mbar			< 30	

**Pumps**

<b>a) Engine driven pumps</b>					
HT circuit cooling water	(2.5 bar)	m <sup>3</sup> /h	69	69	69
LT circuit cooling water	(2.5 bar)	m <sup>3</sup> /h	69	69	69
Lube oil	(4.5 bar)	m <sup>3</sup> /h	66	96	96
<b>b) External pumps <sup>8)</sup></b>					
Diesel oil pump	(5 bar at fuel oil inlet A1)	m <sup>3</sup> /h	1.48	1.73	1.98
Fuel oil supply pump	(4 bar discharge pressure)	m <sup>3</sup> /h	0.71	0.83	0.95
Fuel oil circulating pump	(8 bar at fuel oil inlet A1)	m <sup>3</sup> /h	1.48	1.73	1.98

**Starting air data**

Air consumption per start, incl. air for jet assist (IR/TDI)	Nm <sup>3</sup>	2.9	3.3	3.8	4.3
--	-----------------	-----	-----	-----	-----

- 1) LT cooling water flow first through LT stage charge air cooler, then through lube oil cooler, water temperature outlet engine regulated by mechanical thermostat.
- 2) HT cooling water flow first through HT stage charge air cooler, then through water jacket and cylinder head, water temperature outlet engine regulated by mechanical thermostat.
- 3) Tolerance: + 10% for rating coolers, - 15% for heat recovery.

- 4) Basic values for layout of the coolers.
- 5) Under above mentioned reference conditions.
- 6) Tolerance: quantity +/- 5%, temperature +/- 20°C.
- 7) Under below mentioned temperature at turbine outlet and pressure according above mentioned reference conditions.
- 8) Tolerance of the pumps delivery capacities must be considered by the manufactures.

Fig. 4.09.02b: List of capacities for L27/38, 750 rpm, IMO Tier II



L28/32H-TII GenSet Data

	Bore: 280 mm		Stroke: 320 mm	
	Power layout			
	720 r/min Eng. kW	60 Hz Gen. kW	750 r/min Eng. kW	50 Hz Gen. kW
5L28/32H	1,050	1,000	1,100	1,045
6L28/32H	1,260	1,200	1,320	1,255
7L28/32H	1,470	1,400	1,540	1,465
8L28/32H	1,680	1,600	1,760	1,670
9L28/32H	1,890	1,800	1,980	1,880

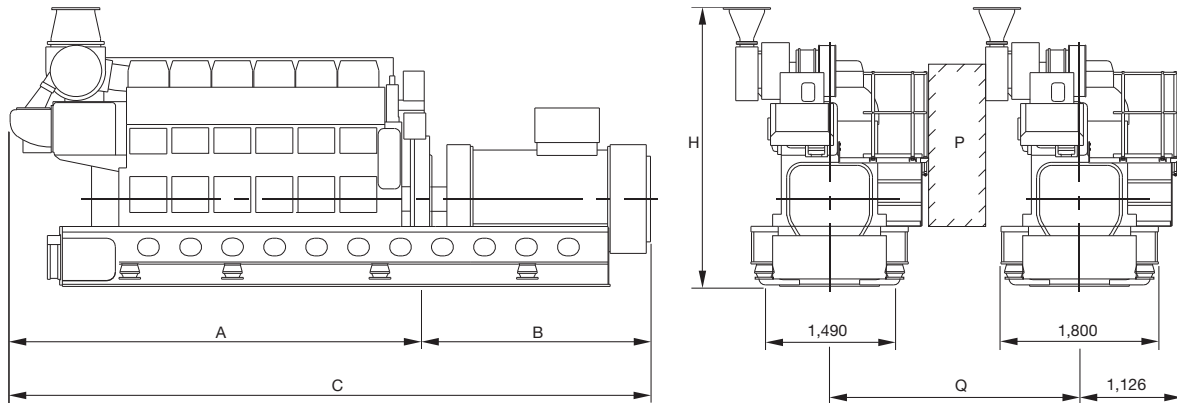

178 23 09-2.0

No. of Cyls.	A (mm)	* B (mm)	* C (mm)	H (mm)	**Dry weight GenSet (t)
5 (720 r/min)	4,279	2,400	6,679	3,184	32.6
5 (750 r/min)	4,279	2,400	6,679	3,184	32.6
6 (720 r/min)	4,759	2,510	7,269	3,184	36.3
6 (750 r/min)	4,759	2,510	7,269	3,184	36.3
7 (720 r/min)	5,499	2,680	8,179	3,374	39.4
7 (750 r/min)	5,499	2,680	8,179	3,374	39.4
8 (720 r/min)	5,979	2,770	8,749	3,374	40.7
8 (750 r/min)	5,979	2,770	8,749	3,374	40.7
9 (720 r/min)	6,199	2,690	8,889	3,534	47.1
9 (750 r/min)	6,199	2,690	8,889	3,534	47.1

P Free passage between the engines, width 600 mm and height 2,000 mm  
 Q Min. distance between engines: 2,655 mm (without gallery) and 2,850 mm (with gallery)  
 \* Depending on alternator  
 \*\* Weight includes a standard alternator, make A. van Kaick  
 All dimensions and masses are approximate and subject to change without prior notice.

178 33 92-1.3

Fig. 4.10.01: Power and outline of L28/32H, IMO Tier II

**L28/32H-TII GenSet Data****5L-9L: 220 kW/Cyl. at 750 rpm****Reference Condition: Tropic**

Air temperature	°C	45
LT water temperature inlet engine (from system)	°C	38
Air pressure	bar	1
Relative humidity	%	50

Number of Cylinders	-	5	6	7	8	9
Engine output	kW	1,100	1,320	1,540	1,760	1,980
Speed	rpm	750				

**Heat to be dissipated <sup>1)</sup>**

Cooling water (C.W.) Cylinder	kW	245	294	343	392	442
Charge air cooler; cooling water HT	kW			0		
				(Single stage charge air cooler)		
Charge air cooler; cooling water LT	kW	387	435	545	587	648
Lube oil (L.O.) cooler	kW	201	241	281	321	361
Heat radiation engine	kW	27	33	38	44	49

**Flow rates <sup>2)</sup>**

Internal (inside engine)						
HT cooling water cylinder	m <sup>3</sup> /h	37	45	50	55	60
LT cooling water lube oil cooler *	m <sup>3</sup> /h	7.8	9.4	11	12.7	14.4
LT cooling water lube oil cooler **	m <sup>3</sup> /h	28	28	40	40	40
LT cooling water charge air cooler	m <sup>3</sup> /h	37	45	55	65	75

**Air data**

Temperature of charge air at charge air cooler outlet	°C	52	54	52	52	55
Air flow rate	m <sup>3</sup> /h <sup>3)</sup>	7,826	9,391	10,956	12,521	14,087
	kg/kWh	7.79	7.79	7.79	7.79	7.79
Charge air pressure	bar			3.07		
Air required to dissipate heat radiation (engine) (t <sub>2</sub> -t <sub>1</sub> =10°C)	m <sup>3</sup> /h	8,749	10,693	12,313	14,257	15,878

**Exhaust gas data <sup>4)</sup>**

Volume flow (temperature turbocharger outlet)	m <sup>3</sup> /h <sup>5)</sup>	15,520	18,624	21,728	24,832	27,936
Mass flow	t/h	8.8	10.5	12.3	14.1	15.8
Temperature at turbine outlet	°C	342	342	342	342	342
Heat content (190°C)	kW	401	481	561	641	721
Permissible exhaust back pressure	mbar			< 30		

**Pumps**

a) Engine driven pumps						
Fuel oil feed pump	(5,5-7,5 bar)	m <sup>3</sup> /h	1.4	1.4	1.4	1.4
HT circuit cooling water	(1,0-2,5 bar)	m <sup>3</sup> /h	45	45	60	60
LT circuit cooling water	(1,0-2,5 bar)	m <sup>3</sup> /h	45	60	75	75
Lube oil	(3,0-5,0 bar)	m <sup>3</sup> /h	24	24	34	34
b) External pumps <sup>6)</sup>						
Diesel oil pump	(4 bar at fuel oil inlet A1)	m <sup>3</sup> /h	0.78	0.93	1.09	1.24
Fuel oil supply pump	(4 bar discharge pressure)	m <sup>3</sup> /h	0.37	0.45	0.52	0.60
Fuel oil circulating pump	(8 bar at fuel oil inlet A1)	m <sup>3</sup> /h	0.78	0.93	1.09	1.24
HT circuit cooling water	(1,0-2,5 bar)	m <sup>3</sup> /h	37	45	50	55
LT circuit cooling water	(1,0-2,5 bar) *	m <sup>3</sup> /h	45	54	65	77
LT circuit cooling water	(1,0-2,5 bar) **	m <sup>3</sup> /h	65	73	95	105
Lube oil	(3,0-5,0 bar)	m <sup>3</sup> /h	22	23	25	27

1) Tolerance: + 10% for rating coolers, - 15% for heat recovery

2) Basic values for layout of the coolers

3) Under above mentioned reference conditions

4) Tolerance: quantity +/- 5%, temperature +/- 20°C

5) under below mentioned temperature at turbine outlet and pressure according above mentioned reference conditions

6) Tolerance of the pumps delivery capacities must be considered by the manufactures

\* Only valid for engines equipped with internal basic cooling water system no. 1 and 2.

\*\* Only valid for engines equipped with combined coolers, internal basic cooling water system no. 3

Fig. 4.10.02a: List of capacities for L28/32H, 750 rpm, IMO Tier II

**L28/32H-TII GenSet Data****5L-9L: 210 kW/Cyl. at 720 rpm****Reference Condition: Tropic**

Air temperature	°C	45				
LT water temperature inlet engine (from system)	°C	38				
Air pressure	bar	1				
Relative humidity	%	50				

<b>Number of Cylinders</b>	-	<b>5</b>	<b>6</b>	<b>7</b>	<b>8</b>	<b>9</b>
Engine output	kW	1,050	1,260	1,470	1,680	1,890
Speed	rpm	720				

**Heat to be dissipated <sup>1)</sup>**

Cooling water (C.W.) Cylinder	kW	234	281	328	375	421
Charge air cooler; cooling water HT	kW	0				
		(Single stage charge air cooler)				
Charge air cooler; cooling water LT	kW	355	397	500	553	592
Lube oil (L.O.) cooler	kW	191	230	268	306	345
Heat radiation engine	kW	26	31	36	42	47

**Flow rates <sup>2)</sup>****Internal (inside engine)**

HT cooling water cylinder	m <sup>3</sup> /h	37	45	50	55	60
LT cooling water lube oil cooler *	m <sup>3</sup> /h	7.8	9.4	11	12.7	14.4
LT cooling water lube oil cooler **	m <sup>3</sup> /h	28	28	40	40	40
LT cooling water charge air cooler	m <sup>3</sup> /h	37	45	55	65	75

**Air data**

Temperature of charge air at charge air cooler outlet	°C	51	52	51	52	53
Air flow rate	m <sup>3</sup> /h <sup>3)</sup>	7,355	8,826	10,297	11,768	13,239
	kg/kWh	7.67	7.67	7.67	7.67	7.67
Charge air pressure	bar	2.97				
Air required to dissipate heat radiation (engine) (t <sub>2</sub> -t <sub>1</sub> =10°C)	m <sup>3</sup> /h	8,425	10,045	11,665	13,609	15,230

**Exhaust gas data <sup>4)</sup>**

Volume flow (temperature turbocharger outlet)	m <sup>3</sup> /h <sup>5)</sup>	14,711	17,653	20,595	23,537	26,479
Mass flow	t/h	8.3	9.9	11.6	13.2	14.9
Temperature at turbine outlet	°C	347	347	347	347	347
Heat content (190°C)	kW	389	467	545	623	701
Permissible exhaust back pressure	mbar	< 30				

**Pumps****a) Engine driven pumps**

Fuel oil feed pump	(5,5-7,5 bar)	m <sup>3</sup> /h	1.4	1.4	1.4	1.4	1.4
HT circuit cooling water	(1,0-2,5 bar)	m <sup>3</sup> /h	45	45	60	60	60
LT circuit cooling water	(1,0-2,5 bar)	m <sup>3</sup> /h	45	60	75	75	75
Lube oil	(3,0-5,0 bar)	m <sup>3</sup> /h	24	24	34	34	34

**b) External pumps <sup>6)</sup>**

Diesel oil pump	(4 bar at fuel oil inlet A1)	m <sup>3</sup> /h	0.74	0.89	1.04	1.19	1.34
Fuel oil supply pump	(4 bar discharge pressure)	m <sup>3</sup> /h	0.36	0.43	0.50	0.57	0.64
Fuel oil circulating pump	(8 bar at fuel oil inlet A1)	m <sup>3</sup> /h	0.74	0.89	1.04	1.19	1.34
HT circuit cooling water	(1,0-2,5 bar)	m <sup>3</sup> /h	37	45	50	55	60
LT circuit cooling water	(1,0-2,5 bar) *	m <sup>3</sup> /h	45	54	65	77	89
LT circuit cooling water	(1,0-2,5 bar) **	m <sup>3</sup> /h	65	73	95	105	115
Lube oil	(3,0-5,0 bar)	m <sup>3</sup> /h	22	23	25	27	28

1) Tolerance: + 10% for rating coolers, - 15% for heat recovery

2) Basic values for layout of the coolers

3) under above mentioned reference conditions

4) Tolerance: quantity +/- 5%, temperature +/- 20°C

5) Under below mentioned temperature at turbine outlet and pressure according above mentioned reference conditions

6) Tolerance of the pumps delivery capacities must be considered by the manufactures

\* Only valid for engines equipped with internal basic cooling water system no. 1 and 2.

\*\* Only valid for engines equipped with combined coolers, internal basic cooling water system no. 3

Fig. 4.10.02b: List of capacities for L28/32H, 720 rpm, IMO Tier II.



L32/40-TII GenSet Data

	Bore: 320 mm		Stroke: 400 mm	
	Power layout			
	720 r/min Eng. kW	60 Hz Gen. kW	750 r/min Eng. kW	50 Hz Gen. kW
6L32/40	3,000	2,895	3,000	2,895
7L32/40	3,500	3,380	3,500	3,380
8L32/40	4,000	3,860	4,000	3,860
9L32/40	4,500	4,345	4,500	4,345

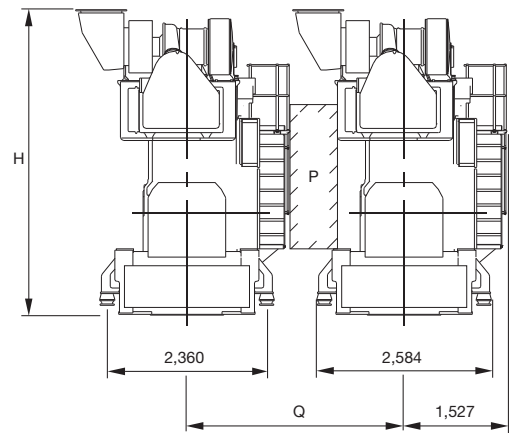
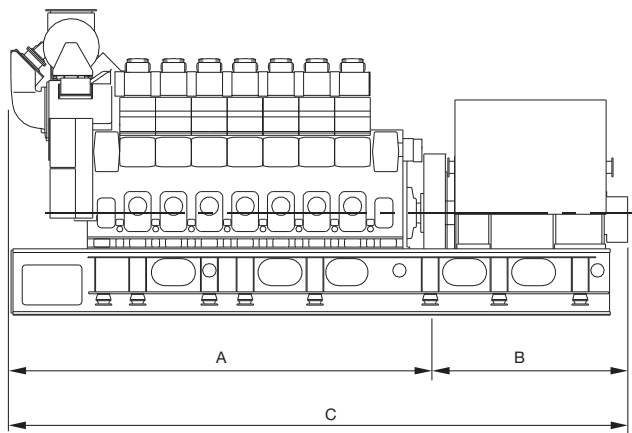

178 23 10-2.0

No of Cyls.	A (mm)	* B (mm)	* C (mm)	H (mm)	**Dry weight GenSet (t)
6 (720 r/min)	6,340	3,415	9,755	4,510	75.0
6 (750 r/min)	6,340	3,415	9,755	4,510	75.0
7 (720 r/min)	6,870	3,415	10,285	4,510	79.0
7 (750 r/min)	6,870	3,415	10,285	4,510	79.0
8 (720 r/min)	7,400	3,635	11,035	4,780	87.0
8 (750 r/min)	7,400	3,635	11,035	4,780	87.0
9 (720 r/min)	7,930	3,635	11,565	4,780	91.0
9 (750 r/min)	7,930	3,635	11,565	4,780	91.0

P Free passage between the engines, width 600 mm and height 2,000 mm  
 Q Min. distance between engines: 2,835 mm (without gallery) and 3,220 mm (with gallery)  
 \* Depending on alternator  
 \*\* Weight includes an alternator, Type B16, Make Siemens  
 All dimensions and masses are approximate and subject to change without prior notice.

178 34 55-7.3

Fig. 4.11.01: Power and outline of 32/40, IMO Tier II





**L32/40-TII GenSet Data**

**6L-9L: 500 kW/Cyl. at 720/750 rpm diesel-electric, 750 rpm diesel-mechanic**

**Reference Condition: Tropic**

Nominal values for cooler specification

Air temperature	°C	45
LT water temperature inlet engine (from system)	°C	38
Air pressure	bar	1
Relative humidity	%	50

Number of Cylinders	-	6	7	8	9
Engine output	kW	3000	3500	4000	4500

**Heat to be dissipated <sup>1)</sup>**

Cooling water cylinder	kW	416	485	555	624
Charge air cooler; cooling water HT	kW	734	821	952	1036
Charge air cooler; cooling water LT	kW	366	428	502	565
Lube oil cooler + separator 2)	kW	426	497	568	639
Cooling water fuel nozzles	kW	12	14	16	18
Heat radiation engine	kW	104	121	139	156

**Flow rates engine <sup>3)</sup>**

HT circuit (cooling water cylinder + charge air cooler HT)	m <sup>3</sup> /h	36	42	48	54
LT circuit (lube oil cooler + charge air cooler LT)	m <sup>3</sup> /h	57	70	74	85
Lube oil (4 bar before engine)	m <sup>3</sup> /h	100	110	120	150
Cooling water fuel nozzles	m <sup>3</sup> /h	1.0	1.2	1.4	1.6

**Pumps**

a) Free standing pumps <sup>4)</sup>

HT circuit cooling water (4.5 bar)	m <sup>3</sup> /h	36	42	48	54
LT circuit cooling water (3.0 bar)	m <sup>3</sup> /h		depending on plant design		
Lube oil (8.0 bar)	m <sup>3</sup> /h	100 + z	110 + z	120 + z	130 + z
Cooling water fuel nozzles (3.0 bar)	m <sup>3</sup> /h	1.0	1.2	1.4	1.6
Fuel supply (7.0 bar)	m <sup>3</sup> /h	1.1	1.3	1.5	1.6
Fuel booster (7.0 bar at fuel oil inlet A1)	m <sup>3</sup> /h	2.1	2.4	2.8	3.1

b) Attached pumps

Lube oil (8.0 bar); constant speed	m <sup>3</sup> /h	120	120	141	141
Lube oil (8.0 bar); variable speed	m <sup>3</sup> /h	120	141	162	162

- 1) Tolerance: + 10% for rating coolers, - 15% for heat recovery
- 2) Including separator heat (30kJ/kWh)
- 3) Basic values for layout of the coolers
- 4) Tolerance of the pumps delivery capacities must be considered by the manufactures.
- z Flushing oil of the automatic filter

Fig. 4.11.02a: List of capacities for L32/40, IMO Tier II

178 23 11-4.0



**L32/40-TII GenSet Data**

**6L-9L: 500 kW/Cyl. at 720/750 rpm diesel-electric, 750 rpm diesel-mechanic**

**Reference Condition : Tropic**

Temperature basis, nominal air and exhaust gas data

Air temperature	°C			45	
LT water temperature inlet engine (from system)	°C			38	
Air pressure	bar			1	
Relative humidity	%			50	

<b>Number of Cylinders</b>	-	<b>6</b>	<b>7</b>	<b>8</b>	<b>9</b>
Engine output	kW	3,000	3,500	4,000	4,500

**Temperature basis**

HT cooling water engine outlet	°C			90	
LT cooling water air cooler inlet	°C		38 (Setpoint 32°C) <sup>1)</sup>		
Lube oil inlet engine	°C			65	
Cooling water inlet fuel nozzles	°C			60	

**Air data**

Temperature of charge air at charge air cooler outlet	°C	57	58	57	58
Air flow rate	m <sup>3</sup> /h <sup>2)</sup>	18,450	21,550	24,650	27,670
Mass flow	t/h	20.2	23.6	27.0	30.3
Charge air pressure (absolute)	bar			3.93	
Air required to dissipate heat radiation (engine) (t <sup>2</sup> -t <sup>1</sup> =10°C)	m <sup>3</sup> /h	33,700	39,200	45,050	50,550

**Exhaust gas data 3)**

Volume flow (temperature turbocharger outlet)	m <sup>3</sup> /h <sup>4)</sup>	38,100	44,550	50,750	57,150
Mass flow	t/h	20.8	24.3	27.7	31.2
Temperature at turbine outlet	°C			365	
Heat content (190°C)	kW	1,150	1,350	1,500	1,700
Permissible exhaust back pressure after turbocharger	mbar			30	

- 1) For design see section "Cooling water system"
- 2) Under above mentioned reference conditions
- 3) Tolerance: Quantity +/- 5%, temperature +/- 20°C
- 4) Under below mentioned temperature at turbine outlet and pressure according above mentioned reference conditions

Fig. 4.11.02b: List of capacities for L32/40, IMO Tier II



**MAN B&W**

---

# Installation Aspects

**5**

---

**MAN Diesel**



## Space Requirements and Overhaul Heights

*The latest version of most of the drawings of this section is available for download at [www.marine.man.eu](http://www.marine.man.eu) → 'Two-Stroke' → 'Installation Drawings'. First choose engine series, then engine type and select from the list of drawings available for download.*

### Space Requirements for the Engine

The space requirements stated in Section 5.02 are valid for engines rated at nominal MCR ( $L_1$ ).

The additional space needed for engines equipped with PTO is stated in Chapter 4.

If, during the project stage, the outer dimensions of the turbocharger seem to cause problems, it is possible, for the same number of cylinders, to use turbochargers with smaller dimensions by increasing the indicated number of turbochargers by one, see Chapter 3.

### Overhaul of Engine

The distances stated from the centre of the crankshaft to the crane hook are for the normal lifting procedure and the reduced height lifting procedure (involving tilting of main components). The lifting capacity of a normal engine room crane can be found in Fig. 5.04.01.

The area covered by the engine room crane shall be wide enough to reach any heavy spare part required in the engine room.

A lower overhaul height is, however, available by using the MAN B&W Double-Jib crane, built by Danish Crane Building A/S, shown in Figs. 5.04.02 and 5.04.03.

Please note that the distance 'E' in Fig. 5.02.01, given for a double-jib crane is from the centre of the crankshaft to the lower edge of the deck beam.

A special crane beam for dismantling the turbo-

charger must be fitted. The lifting capacity of the crane beam for dismantling the turbocharger is stated in Section 5.03.

The overhaul tools for the engine are designed to be used with a crane hook according to DIN 15400, June 1990, material class M and load capacity 1Am and dimensions of the single hook type according to DIN 15401, part 1.

The total length of the engine at the crankshaft level may vary depending on the equipment to be fitted on the fore end of the engine, such as adjustable counterweights, tuning wheel, moment compensators or PTO.



### Crane beam for overhaul of turbocharger

For the overhaul of a turbocharger, a crane beam with trolleys is required at each end of the turbocharger.

Two trolleys are to be available at the compressor end and one trolley is needed at the gas inlet end.

Crane beam no. 1 is for dismantling of turbocharger components.

Crane beam no. 2 is for transporting turbocharger components.

See Figs. 5.03.01a and 5.03.02.

The crane beams can be omitted if the main engine room crane also covers the turbocharger area.

The crane beams are used and dimensioned for lifting the following components:

- Exhaust gas inlet casing
- Turbocharger inlet silencer
- Compressor casing
- Turbine rotor with bearings

The crane beams are to be placed in relation to the turbocharger(s) so that the components around the gas outlet casing can be removed in connection with overhaul of the turbocharger(s).

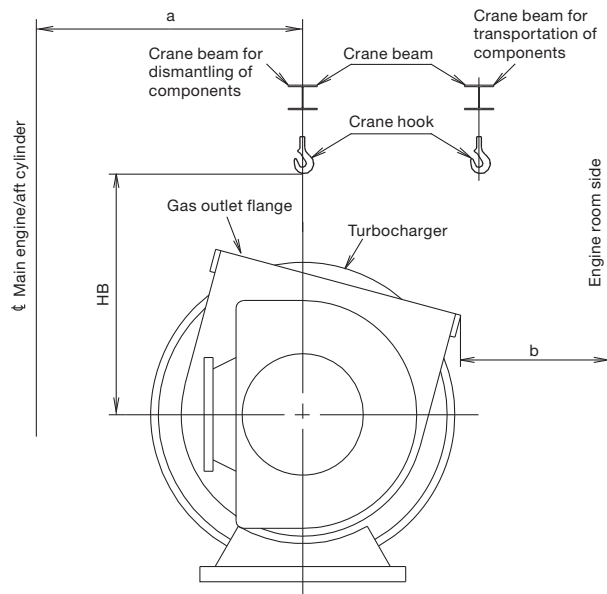

178 52 34-0.1

Fig. 5.03.01a: Required height and distance

The crane beam can be bolted to brackets that are fastened to the ship structure or to columns that are located on the top platform of the engine.

The lifting capacity of the crane beam for the heaviest component 'W', is indicated in Fig. 5.03.01b for the various turbocharger makes. The crane beam shall be dimensioned for lifting the weight 'W' with a deflection of some 5 mm only.

HB indicates the position of the crane hook in the vertical plane related to the centre of the turbocharger. HB and b also specifies the minimum space for dismantling.

For engines with the turbocharger(s) located on the exhaust side, EoD No. 4 59 122, the letter 'a' indicates the distance between vertical centrelines of the engine and the turbocharger.

MAN B&W			
	Units	TCA77	TCA88
<b>W</b>	kg	2,000	3,000
<b>HB</b>	mm	1,800	2,000
<b>b</b>	m	800	1,000

ABB							
	Units	A180	A185	A190	A275	A280	A285
<b>W</b>	kg	*)					
<b>HB</b>	mm	1,975	2,350	2,425	1,900	2,100	2,350
<b>b</b>	m	600	600	700	500	600	600

Mitsubishi				
	Units	MET71	MET83	MET90
<b>W</b>	kg	1,800	2,700	3,500
<b>HB</b>	mm	1,800	2,200	2,200
<b>b</b>	m	800	800	800

The figures 'a' are stated on the 'Engine and Gallery Outline' drawing, Section 5.06.

\*) Available on request

Fig. 5.03.01b: Required height and distance and weight



### Crane beam for turbochargers

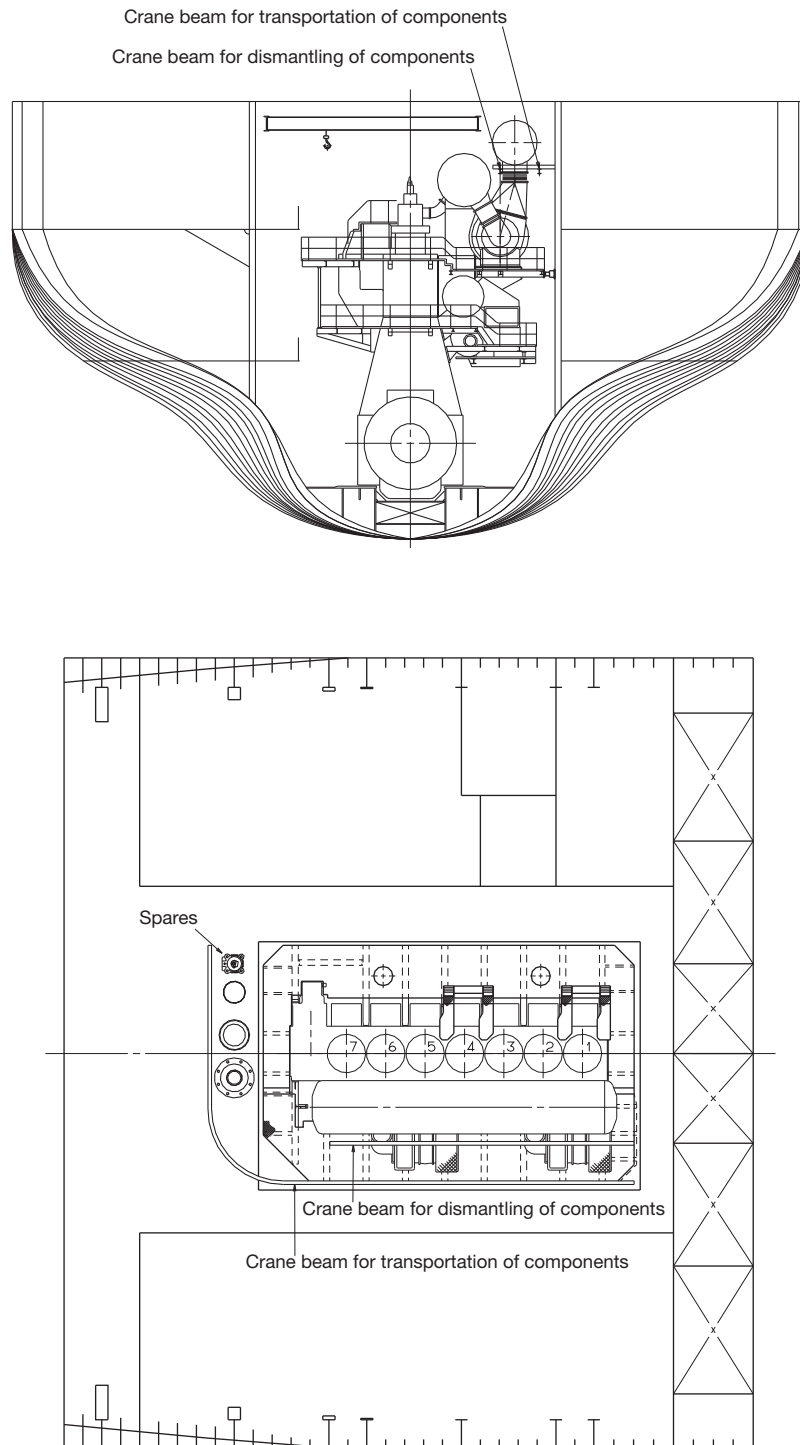

178 52 74-6.0

Fig. 5.03.02: Crane beam for turbocharger



### Crane beam for overhaul of air cooler

Overhaul/exchange of scavenge air cooler.

Valid for air cooler design for the following engines with more than one turbochargers mounted on the exhaust side.

1. Dismantle all the pipes in the area around the air cooler.
2. Dismantle all the pipes around the inlet cover for the cooler.
3. Take out the cooler insert by using the above placed crane beam mounted on the engine.
4. Turn the cooler insert to an upright position.
5. Dismantle the platforms below the air cooler.
6. Lower down the cooler insert between the gallery brackets and down to the engine room floor. Make sure that the cooler insert is supported, e.g. on a wooden support.
7. Move the air cooler insert to an area covered by the engine room crane using the lifting beam mounted below the lower gallery of the engine.
8. By using the engine room crane the air cooler insert can be lifted out of the engine room.

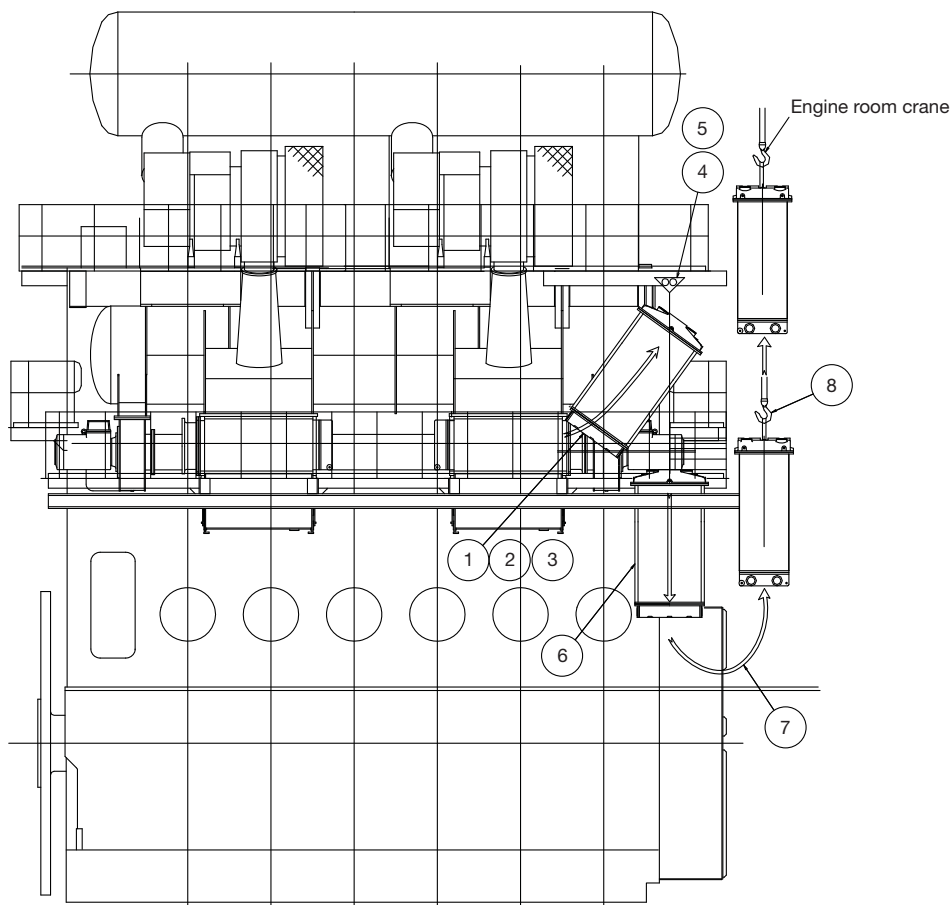

Fig.: 5.03.03: Crane beam for overhaul of air cooler, turbochargers located on exhaust side of the engine

178 52 73-4.0



### Engine room crane

The crane hook travelling area must cover at least the full length of the engine and a width in accordance with dimension A given on the drawing (see cross-hatched area).

It is furthermore recommended that the engine room crane be used for transport of heavy spare parts from the engine room hatch to the spare part stores and to the engine. See example on this drawing.

The crane hook should at least be able to reach down to a level corresponding to the centre line of the crankshaft.

For overhaul of the turbocharger(s), trolley mounted chain hoists must be installed on a separate crane beam or, alternatively, in combination with the engine room crane structure, see separate drawing with information about the required lifting capacity for overhaul of turbochargers.

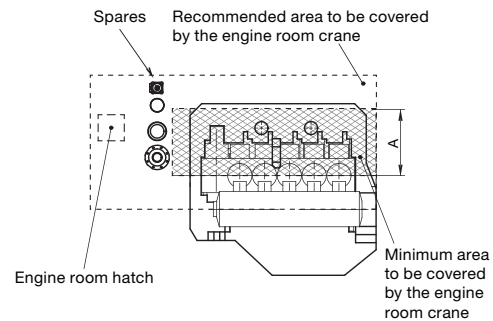
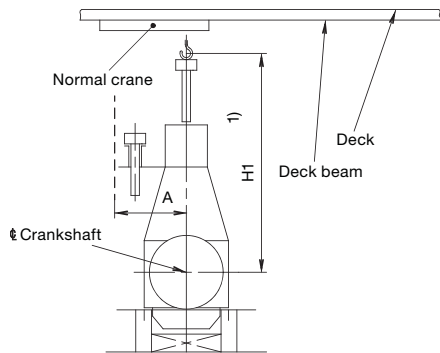

- 1) The lifting tools for the engine are designed to fit together with a standard crane hook with a lifting capacity in accordance with the figure stated in the table. If a larger crane hook is used, it may not fit directly to the overhaul tools, and the use of an intermediate shackle or similar between the lifting tool and the crane hook will affect the requirements for the minimum lifting height in the engine room (dimension H).

541 87 86-0.3.0

Mass in kg including lifting tools			Crane capacity in tons selected in accordance with DIN and JIS standard capacities		Crane operating width in mm	Normal Crane Height to crane hook in mm for:		MAN B&W Double-Jib Crane	
						Normal lifting procedure	Reduced height lifting procedure involving tilting of main components (option)	Building-in height in mm	
Cylinder cover complete with exhaust valve	Cylinder liner with cooling jacket	Piston with rod and stuffing box	Normal crane	MAN B&W Double-Jib Crane	A Minimum distance	H1 Minimum height from centre line crankshaft to centre line crane hook	H2 Minimum height from centre line crankshaft to centre line crane hook	H3 Minimum height from centre line crankshaft to underside deck beam	D Additional height required for removal of exhaust valve complete without removing any exhaust stud
*)	*)	*)	12.5	2x6.3	*)	15,700	*)	*)	*)

\*) Available on request

Fig. 5.04.01: Engine room crane

541 87 86-0.3.0





Overhaul with MAN B&W Double-Jib Crane

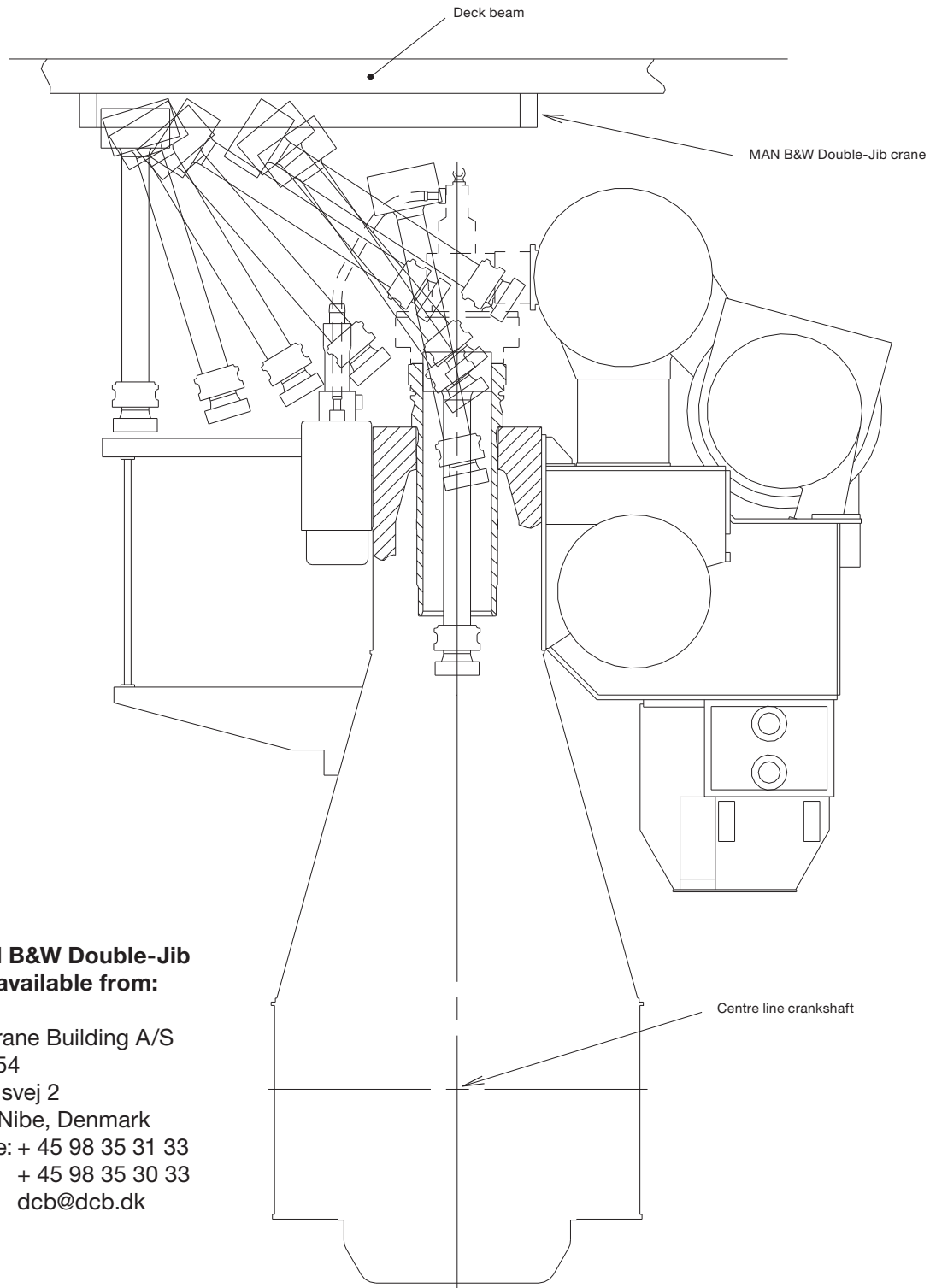

**The MAN B&W Double-Jib crane is available from:**

Danish Crane Building A/S  
P.O. Box 54  
Østerlandsvej 2  
DK-9240 Nibe, Denmark  
Telephone: + 45 98 35 31 33  
Telefax: + 45 98 35 30 33  
E-mail: dcb@dcb.dk

178 24 86-3.2

Fig. 5.04.02: Overhaul with Double-Jib crane



### MAN B&W Double-Jib Crane

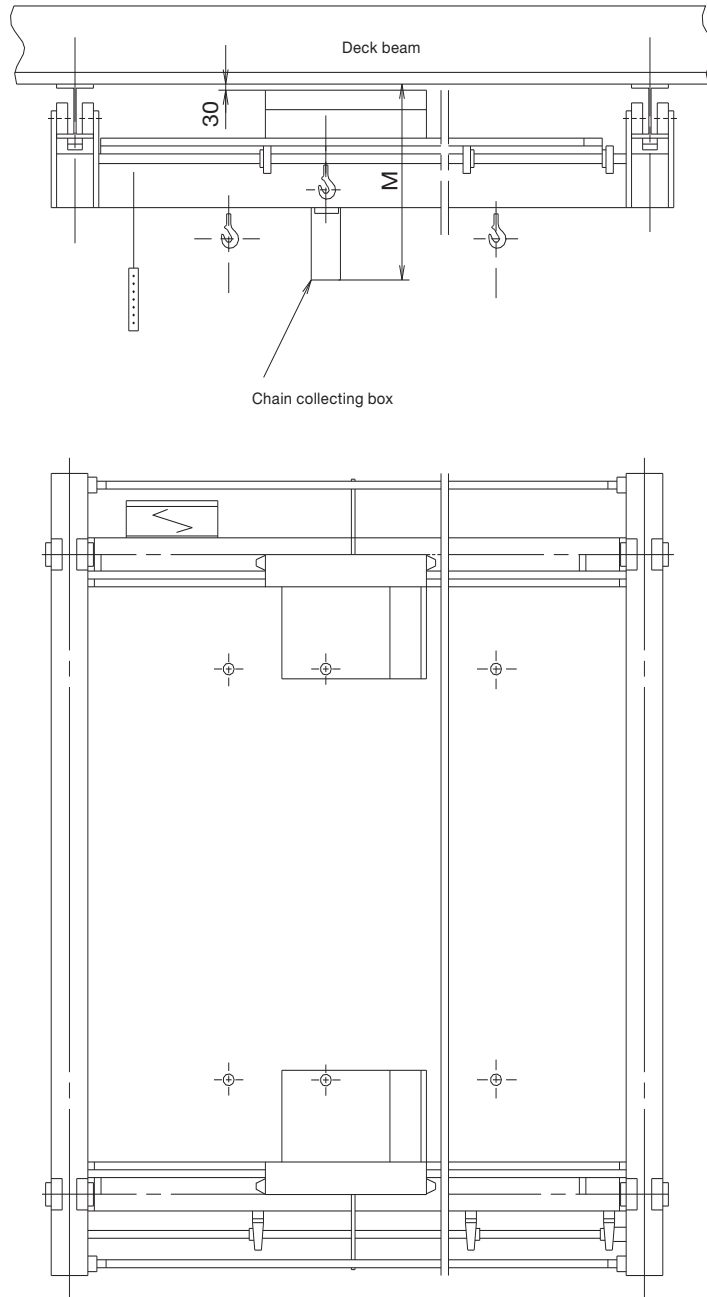

178 37 30-1.1

This crane is adapted to the special tool for low overhaul.

Dimensions are available on request.

Fig. 5.04.03: MAN B&W Double-Jib crane, option: 4 88 701



## **Engine Outline, Galleries and Pipe Connections**

### **Engine outline**

The total length of the engine at the crankshaft level may vary depending on the equipment to be fitted on the fore end of the engine, such as adjustable counterweights, tuning wheel, moment compensators or PTO, which are shown as alternatives in Section 5.06

### **Engine masses and centre of gravity**

The partial and total engine masses appear from Section 19.04, 'Dispatch Pattern', to which the masses of water and oil in the engine, Section 5.08, are to be added. The centre of gravity is shown in Section 5.07, in both cases including the water and oil in the engine, but without moment compensators or PTO.

### **Gallery outline**

Section 5.06 show the gallery outline for engines rated at nominal MCR (L1).

### **Engine pipe connections**

The positions of the external pipe connections on the engine are stated in Section 5.09, and the corresponding lists of counterflanges for pipes and turbocharger in Section 5.10.

The flange connection on the turbocharger gas outlet is rectangular, but a transition piece to a circular form can be supplied as an option: 4 60 601.



### Engine and Gallery Outline

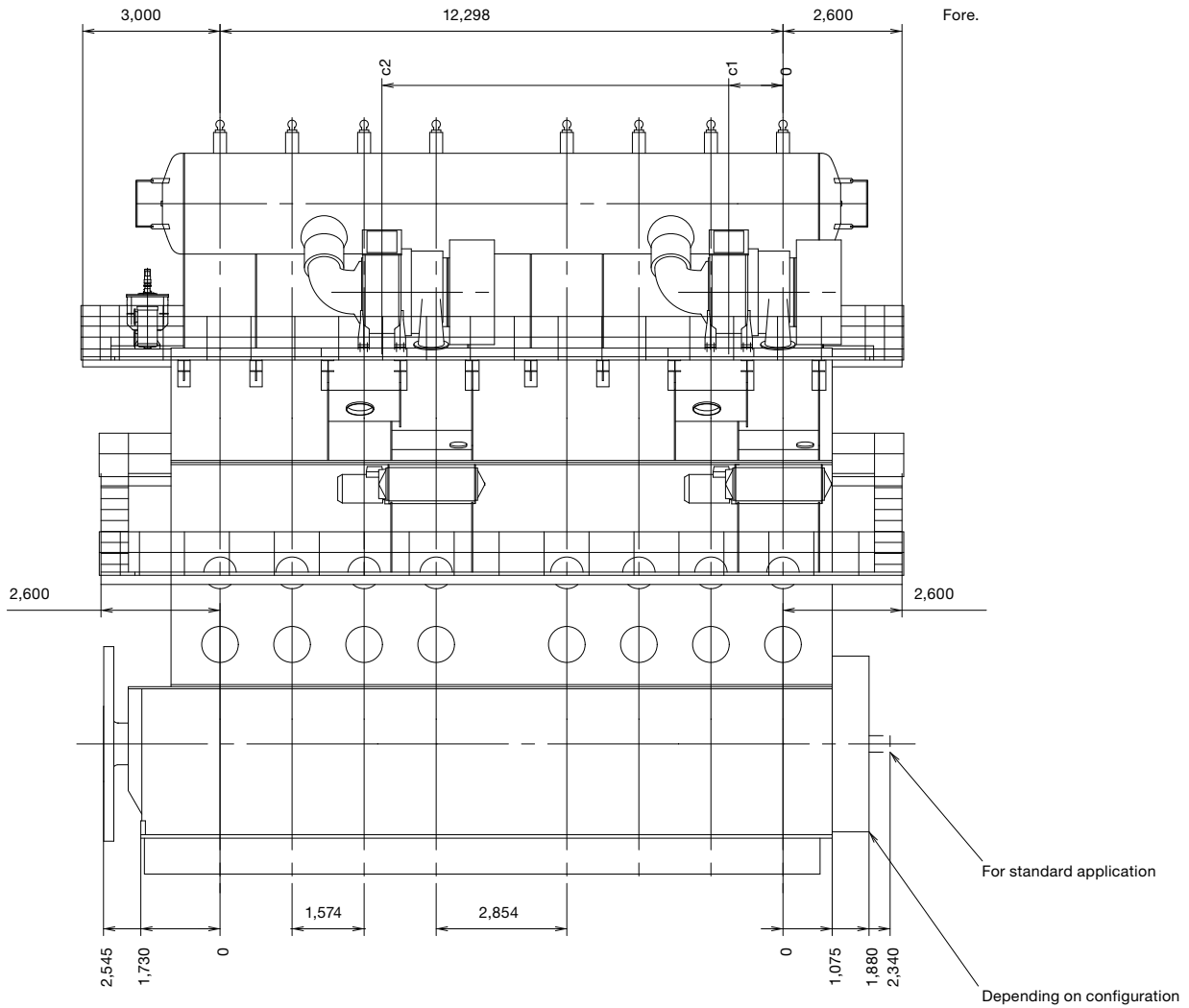

557 22 38-2.4.0a

Fig. 5.06.01a: Engine outline example: 8G95ME-C9 with TCA88 turbochargers on exhaust side

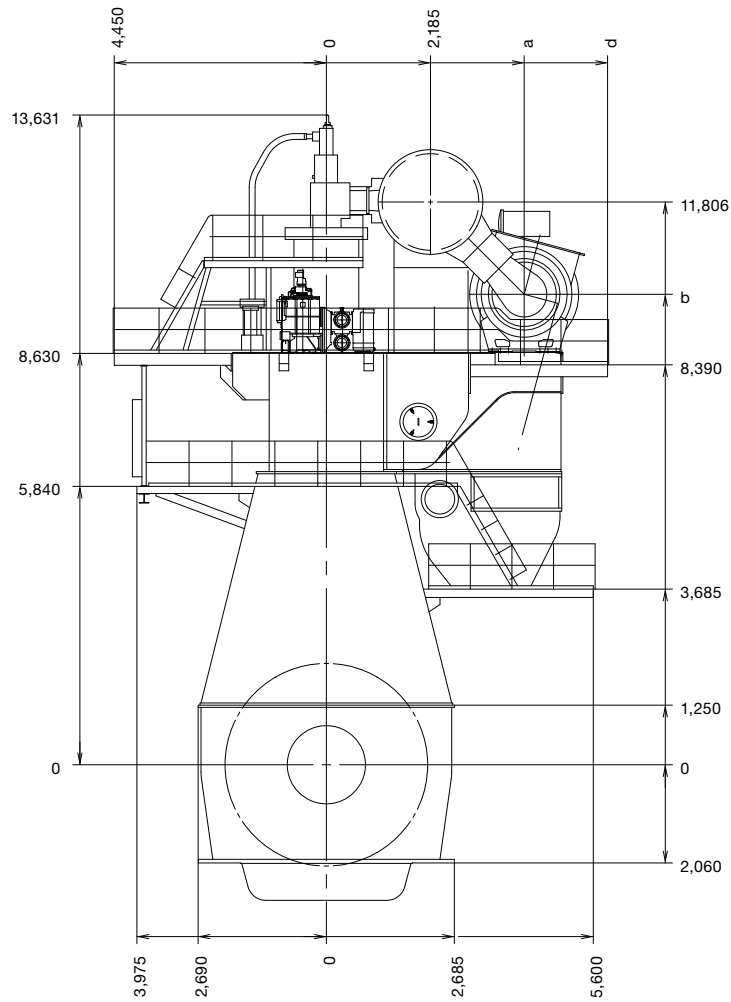

	TC type	a	b	c1	c2	d
MAN	TCA88	4,150	9,870	1,185	8,761	5,900
MHI	MET71MB	4,150	9,585	1,246	8,822	5,900

557 22 38-2.4.0b

Fig. 5.06.01b: Engine outline example: 8G95ME-C9 with TCA88 turbochargers on exhaust side

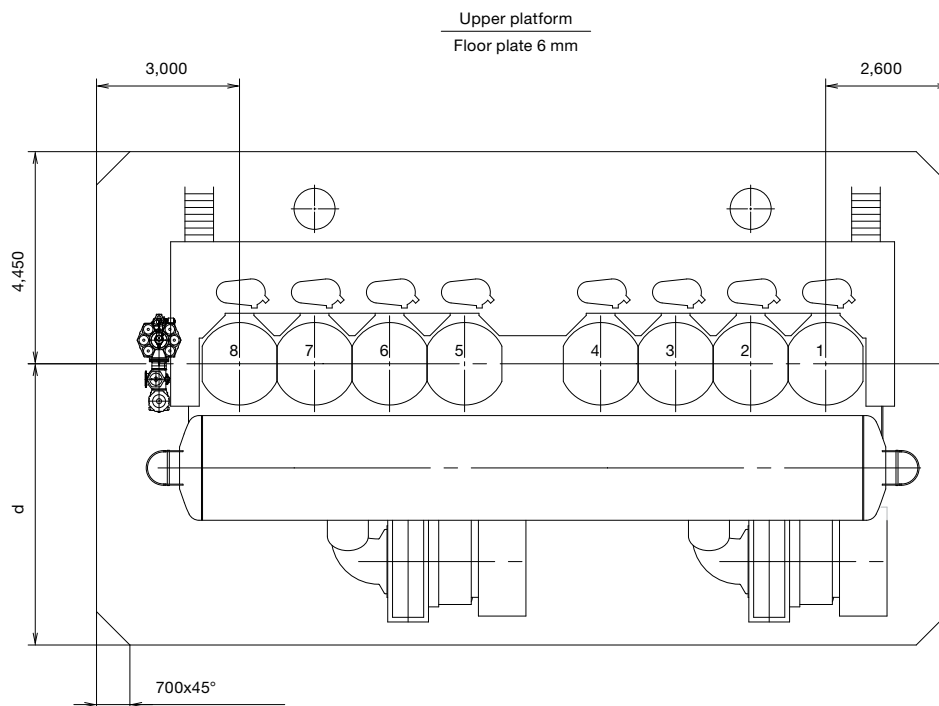

The dimension are in mm and subject to revision without notice.

Please note that the latest version of the dimensioned drawing is available for download at [www.marine.man.eu](http://www.marine.man.eu) → 'Two-Stroke' → 'Installation Drawings'. First choose engine series, then engine type and select 'Outline drawing' for the actual number of cylinders and type of turbocharger installation in the list of drawings available for download.

557 22 38-2.4.0c

Fig. 5.06.01c: Engine outline example: 8G95ME-C9 with TCA88 turbochargers on exhaust side



### Counterflanges, Connection D

#### MAN Type TCA33

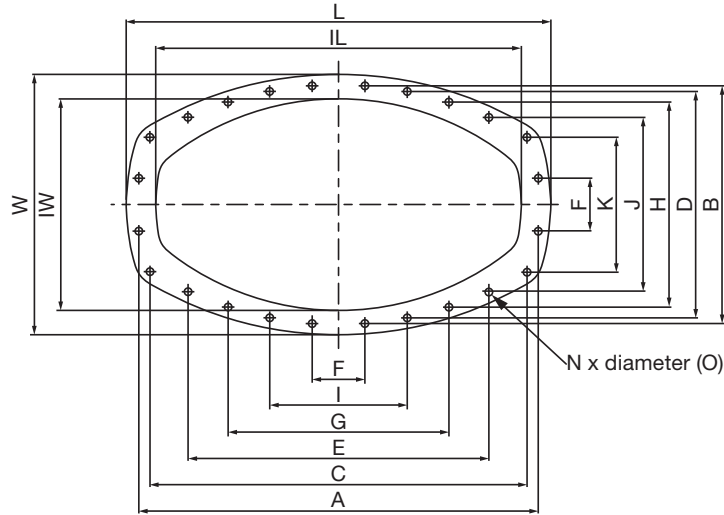

178 63 96-2.0

Type TCA series																	
TC	L	W	IL	IW	A	B	C	D	E	F	G	H	I	J	K	N	O
TCA33	802	492	690	400	755	448	712	427	568	100	417	387	260	329	254	24	ø13,5

#### MAN Type TCA44-99

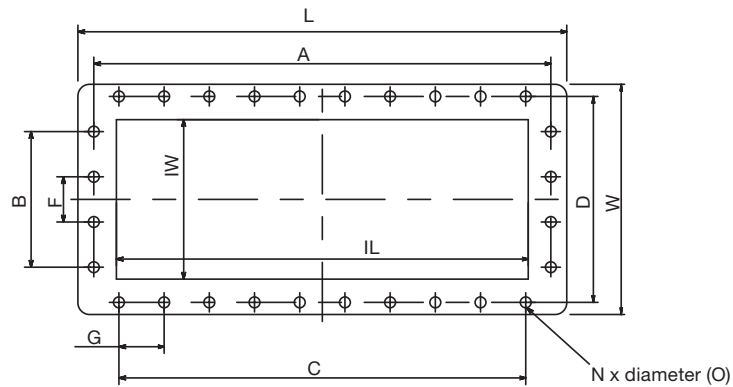

501 29 91-0.13.0a

Type TCA series - Rectangular type													
TC	L	W	IL	IW	A	B	C	D	E	F	G	N	O
TCA44	1,054	444	949	340	1,001	312	826	408	1,012	104	118	24	ø13.5
TCA55	1,206	516	1,080	390	1,143	360	1,000	472	1,155	120	125	26	ø17.5
TCA66	1,433	613	1,283	463	1,358	420	1,200	560	1,373	140	150	26	ø17.5
TCA77	1,694	720	1,524	550	1,612	480	1,440	664	1,628	160	160	28	ø22
TCA88	2,012	855	1,810	653	1,914	570	1,710	788	1,934	190	190	28	ø22
TCA99	2,207	938	1,985	717	2,100	624	1,872	866	2,120	208	208	28	ø22



### Counterflanges, Connection D

#### MAN Type TCR

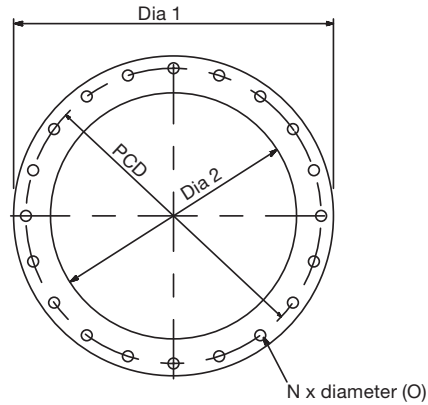

Type TCR series – Round type					
TC	Dia 1	Dia 2	PCD	N	O
TCR18	425	310	395	12	ø22
TCR20	540	373	495	15	ø22
TCR22	595	434	550	16	ø22

501 29 91-0.13.0a

#### ABB Type A100/A200-L

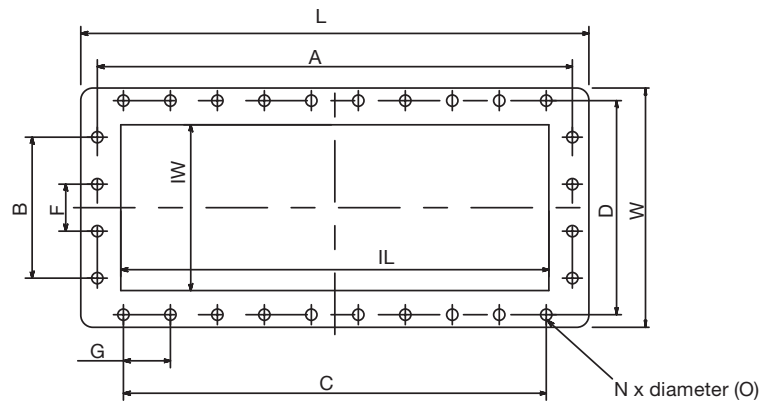

Type A100/A200-L series – Rectangular type												
TC	L	W	IL	IW	A	B	C	D	F	G	N	O
A165/A265-L	1,114	562	950	404	1,050	430	900	511	86	100	32	ø22
A170/A270-L	1,280	625	1,095	466	1,210	450	1,080	568	90	120	32	ø22
A175/A275-L	1,723	770	1,319	562	1,446	510	1,260	710	170	140	28	ø30
A180/A280-L	1,743	856	1,491	634	1,650	630	1,485	786	150	135	36	ø30
A185/A285-L	1,955	958	1,663	707	1,860	725	1,595	886	145	145	36	ø30
A190/A290-L	2,100	1,050	1,834	781	2,000	750	1,760	970	150	160	36	ø30

501 29 91-0.13.0b





MHI Type MET

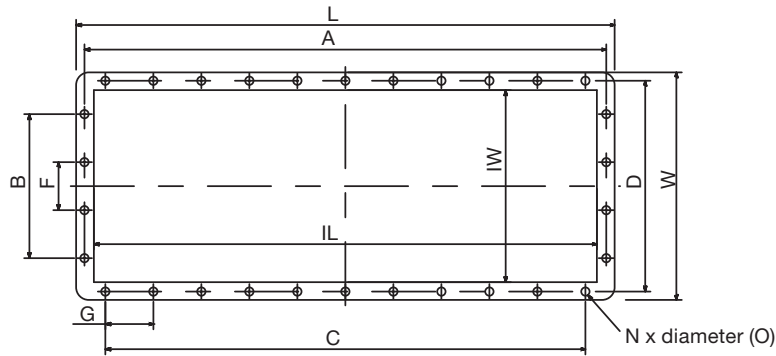

Type MET – Rectangular type												
TC	L	W	IL	IW	A	B	C	D	F	G	N	O
Series MB												
MET42	1,094	381	1,004	291	1,061	261	950	351	87	95	30	ø15
MET53	1,389	485	1,273	369	1,340	330	1,200	440	110	120	30	ø20
MET60	1,528	522	1,418	410	1,488	330	1,320	482	110	110	34	ø20
MET66	1,713	585	1,587	459	1,663	372	1,536	535	124	128	34	ø20
MET71	1,837	617	1,717	497	1,792	480	1,584	572	120	132	36	ø20
MET83	2,163	731	2,009	581	2,103	480	1,920	671	160	160	34	ø24
MET90	2,378	801	2,218	641	2,312	525	2,100	741	175	175	34	ø24
Series MA												
MET33	700	310	605	222	670	0	550	280	130	110	18	ø15
MET42	883	365	793	275	850	240	630	335	80	90	24	ø15
MET53	1,122	465	1,006	349	1,073	300	945	420	100	105	28	ø20
MET60	1,230	500	1,120	388	1,190	315	1,050	460	105	105	30	ø20
MET66	1,380	560	1,254	434	1,330	345	1,200	510	115	120	30	ø20
MET71	1,520	600	1,400	480	1,475	345	1,265	555	115	115	34	ø20
MET83	1,740	700	1,586	550	1,680	450	1,500	640	150	150	30	ø24
MET90	1,910	755	1,750	595	1,850	480	1,650	695	160	165	30	ø24

501 29 91-0.13.0d

Fig. 5.10.02: Turbocharger, exhaust outlet



### Counterflanges, Connection E

#### MAN Type TCA

TC	Dia/ISO	Dia/JIS	PCD	N	O	Thickness of flanges
TCA44	61	77	90	4	14	14

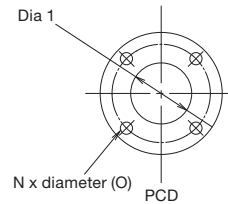

TC	Dia/ISO	Dia/JIS	L	W	N	O	Thickness of flanges
TCA55	61	77	86	76	4	14	16
TCA66	90	90	110	90	4	18	16

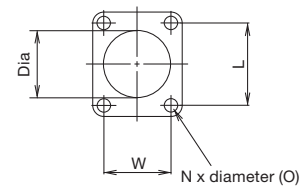

TC	Dia/ISO	Dia/JIS	L	W	N	O	Thickness of flanges
TCA77	115	103	126	72	4	18	18
TCA88	141	141	150	86	4	18	18
TCA99	141	141	164	94	4	22	24

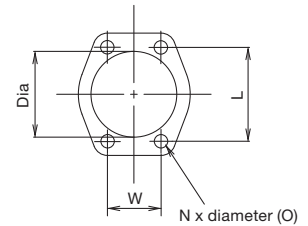

#### ABB Type A100/A200-L

TC	Dia 1	PCD	L + W	N	O	Thickness of flanges
A165/A265-L	77	100	106	8	8,5	18
A170/A270-L	43	100	115	8	11	18
A175/A275-L	77	126	140	8	11	18
A180/A280-L	90	142	158	8	13	18
A185/A285-L	115	157	178	8	13	18
A190/A290-L	115	175	197	8	13	18

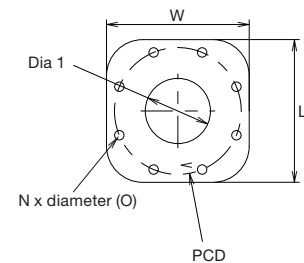



MHI Type MET MB  
Air vent

TC	L+W	Dia 2	PCD	N	O	Thickness of flanges (A)
MET42MB	105	61	105	4	14	14
MET53MB	125	77	130	4	14	14
MET60MB	140	90	145	4	18	14
MET66MB	140	90	145	4	18	14

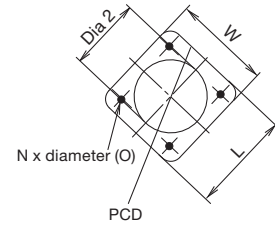

TC	Dia 1	Dia 2	PCD	N	O	Thickness of flanges (A)
MET71MB	180	90	145	4	18	14
MET83MB	200	115	165	4	18	16
MET90MB	200	115	165	4	18	16

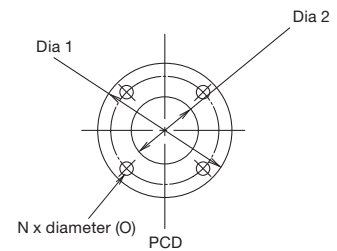

MHI Type MET MB  
Cooling air

TC	L+W	Dia 2	PCD	N	O	Thickness of flanges (A)
MET53MB	95	49	95	4	14	12
MET90MB	125	77	130	4	14	14

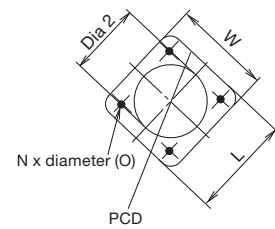

TC	Dia 1	Dia 2	PCD	N	O	Thickness of flanges (A)
MET42MB	95	43	75	4	12	10
MET60MB	120	49	95	4	14	12
MET66MB	120	49	95	4	14	12
MET71MB	120	49	95	4	14	12
MET83MB	120	49	95	4	14	12

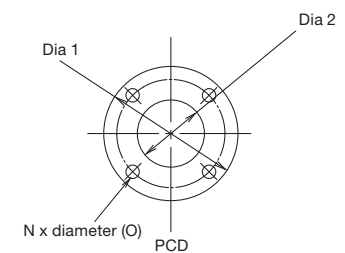
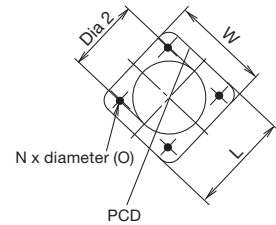

Fig. 5.10.03: Venting of lubricating oil discharge pipe for turbochargers



MHI Type MET MB

TC	L+W	Dia 2	PCD	N	O	Thickness of flanges (A)
MET42MB	105	61	105	4	14	14
MET53MB	125	77	130	4	14	14
MET60MB	140	90	145	4	18	14
MET66MB	140	90	145	4	18	14
MET71MB	140	90	145	4	18	14
MET90MB	155	115	155	4	18	14



TC	Dia 1	Dia 2	PCD	N	O	Thickness of flanges (A)
MET83MB	180	90	145	4	18	14

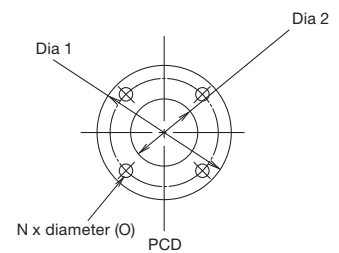

Connection EB

TC	Dia 1	Dia 2	PCD	N	O	Thickness of flanges (A)
MET42MB	95	43	75	4	12	10
MET60MB	120	49	95	4	14	12
MET66MB	120	49	95	4	14	12
MET71MB	120	49	95	4	14	12
MET83MB	120	49	95	4	14	12

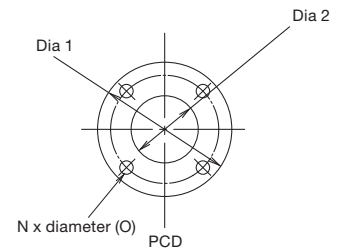

TC	L+W	Dia 2	PCD	N	O	Thickness of flanges (A)
MET53MB	95	49	95	4	14	12
MET90MB	125	77	130	4	14	14

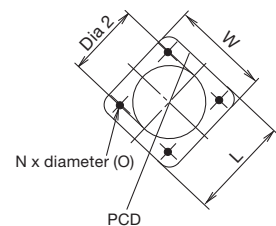

501 29 91-0.13.0c



## Engine Seating and Holding Down Bolts

*The latest version of most of the drawings of this section is available for download at [www.marine.man.eu](http://www.marine.man.eu) → 'Two-Stroke' → 'Installation Drawings'. First choose engine series, then engine type and select 'Engine seating' in the general section of the list of drawings available for download.*

### Engine seating and arrangement of holding down bolts

The dimensions of the seating stated in Figs. 5.12.01 and 5.12.02 are for guidance only.

The engine is designed for mounting on epoxy chocks, EoD: 4 82 102, in which case the underside of the bedplate's lower flanges has no taper.

The epoxy types approved by MAN Diesel & Turbo are:

- 'Chockfast Orange PR 610 TCF' from ITW Philadelphia Resins Corporation, USA
- 'Durasin' from Daemmstoff Industrie Korea Ltd
- 'Epocast 36' from H.A. Springer - Kiel, Germany
- 'EPY' from Marine Service Jaroszewicz S.C., Poland
- 'Loctite Fixmaster Marine Chocking', Henkel





Section B-B

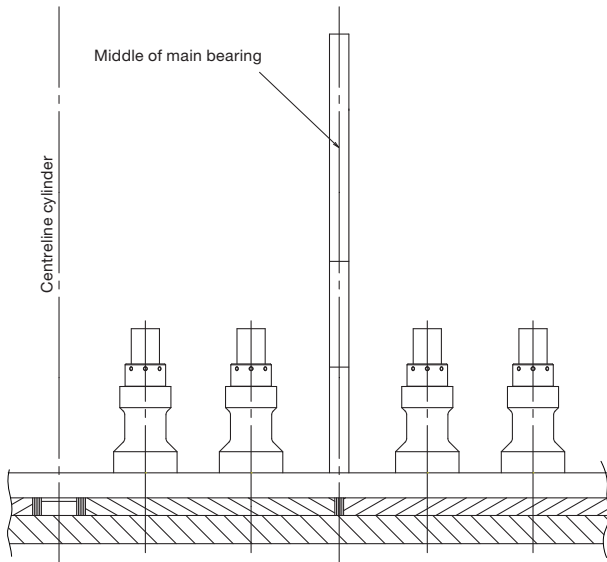

Side chock brackets, option: 4 82 622 includes:

- 1. Side chock brackets

Side chock liners, option: 4 82 620 includes:

- 2. Liner for side chock
- 3. Lock plate
- 4. Washer
- 5. Hexagon socket set screw

Detail D1

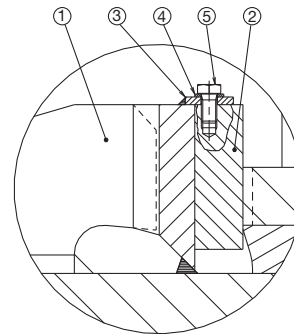

178 13 90-7.2.0b

Fig. 5.12.02b: Profile of engine seating, end chocks, option: 4 82 620

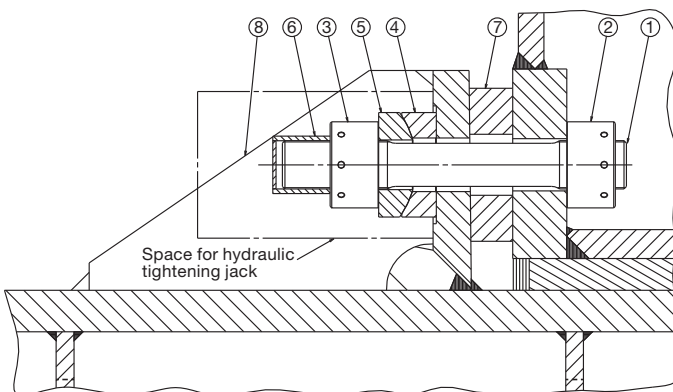

End chock bolts, option: 4 82 610 includes:

- 1. Stud for end chock bolt
- 2. Round nut
- 3. Round nut
- 4. Spherical washer
- 5. Spherical washer
- 6. Protecting cap

End chock liner, option: 4 82 612 includes:

- 7. Liner for end chock

End chock brackets, option: 4 82 614 includes:

- 8. End chock bracket

178 65 98-7.0

Fig. 5.12.02c: Profile of engine seating, end chocks, option: 4 82 610



## Engine Top Bracing

The so-called guide force moments are caused by the transverse reaction forces acting on the crossheads due to the connecting rod and crankshaft mechanism. When the piston of a cylinder is not exactly in its top or bottom position the gas force from the combustion, transferred through the connecting rod, will have a component acting on the crosshead and the crankshaft perpendicularly to the axis of the cylinder. Its resultant is acting on the guide shoe and together they form a guide force moment.

The moments may excite engine vibrations moving the engine top athwart ships and causing a rocking (excited by H-moment) or twisting (excited by X-moment) movement of the engine. For engines with less than seven cylinders, this guide force moment tends to rock the engine in the transverse direction, and for engines with seven cylinders or more, it tends to twist the engine.

The guide force moments are harmless to the engine except when resonance vibrations occur in the engine/double bottom system. They may, however, cause annoying vibrations in the superstructure and/or engine room, if proper counter-measures are not taken.

As a detailed calculation of this system is normally not available, MAN Diesel & Turbo recommends that top bracing is installed between the engine's upper platform brackets and the casing side.

However, the top bracing is not needed in all cases. In some cases the vibration level is lower if the top bracing is not installed. This has normally to be checked by measurements, i.e. with and without top bracing.

If a vibration measurement in the first vessel of a series shows that the vibration level is acceptable without the top bracing, we have no objection to the top bracing being removed and the rest of the series produced without top bracing. It is our experience that especially the 7-cylinder engine will often have a lower vibration level without top bracing.

**Without top bracing**, the natural frequency of the vibrating system comprising engine, ship's bottom, and ship's side is often so low that resonance with the excitation source (the guide force moment) can occur close to the normal speed range, resulting in the risk of vibration.

**With top bracing**, such a resonance will occur above the normal speed range, as the natural frequencies of the double bottom/main engine system will increase. The impact of vibration is thus lowered.

The top bracing is normally installed on the exhaust side of the engine, but can alternatively be installed on the manoeuvring side. A combination of exhaust side and manoeuvring side installation is also possible.

The top bracing system is installed either as a mechanical top bracing or a hydraulic top bracing. Both systems are described below.

### Mechanical top bracing

The mechanical top bracing comprises stiff connections between the engine and the hull.

The top bracing stiffener consists of a double bar tightened with friction shims at each end of the mounting positions. The friction shims allow the top bracing stiffener to move in case of displacements caused by thermal expansion of the engine or different loading conditions of the vessel. Furthermore, the tightening is made with a well-defined force on the friction shims, using disc springs, to prevent overloading of the system in case of an excessive vibration level.





The mechanical top bracing is to be made by the shipyard in accordance with MAN Diesel & Turbo instructions.

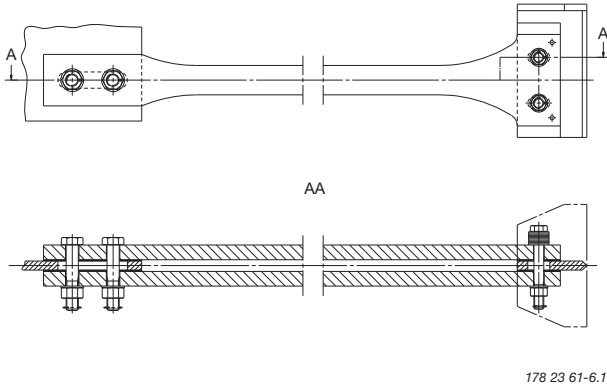

Fig. 5.13.01: Mechanical top bracing stiffener. Option: 4 83 112

Hydraulic top bracing

The hydraulic top bracing is an alternative to the mechanical top bracing used mainly on engines with a cylinder bore of 50 or more. The installation normally features two, four or six independently working top bracing units.

The top bracing unit consists of a single-acting hydraulic cylinder with a hydraulic control unit and an accumulator mounted directly on the cylinder unit.

The top bracing is controlled by an automatic switch in a control panel, which activates the top bracing when the engine is running. It is possible to programme the switch to choose a certain rpm range, at which the top bracing is active. For service purposes, manual control from the control panel is also possible.

When active, the hydraulic cylinder provides a pressure on the engine in proportion to the vibration level. When the distance between the hull and engine increases, oil flows into the cylinder under pressure from the accumulator. When the distance decreases, a non-return valve prevents the oil from flowing back to the accumulator, and the pressure rises. If the pressure reaches a preset maximum value, a relief valve allows the oil to flow back to the accumulator, hereby maintaining the force on the engine below the specified value.

By a different pre-setting of the relief valve, the top bracing is delivered in a low-pressure version (26 bar) or a high-pressure version (40 bar).

The top bracing unit is designed to allow displacements between the hull and engine caused by thermal expansion of the engine or different loading conditions of the vessel.

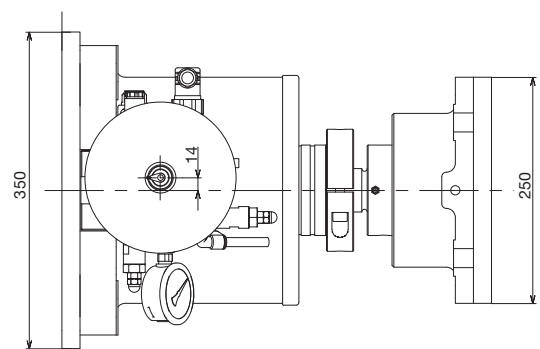
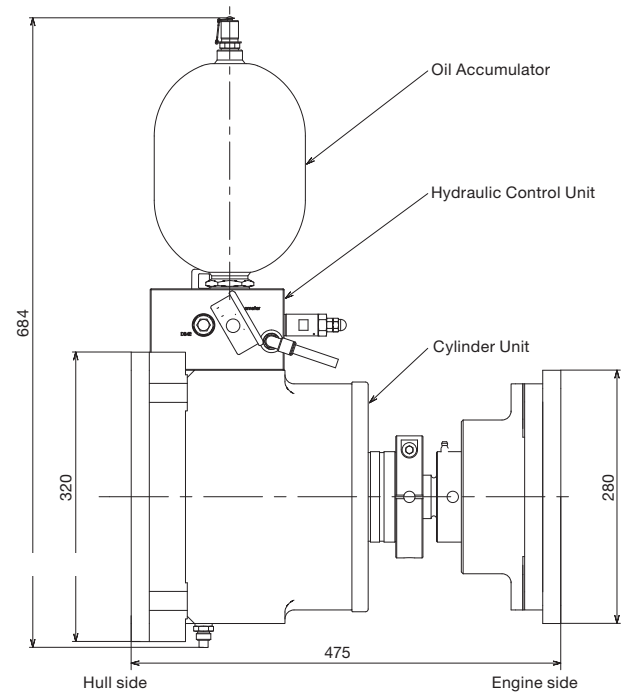

178 57 48-8.0

Fig. 5.13.02: Outline of a hydraulic top bracing unit. The unit is installed with the oil accumulator pointing either up or down. Option: 4 83 123



### Hydraulic Top Bracing Arrangement

Hydraulic top bracing should be installed on one side, either the exhaust side (alternative 1), or the camshaft side (alternative 2).

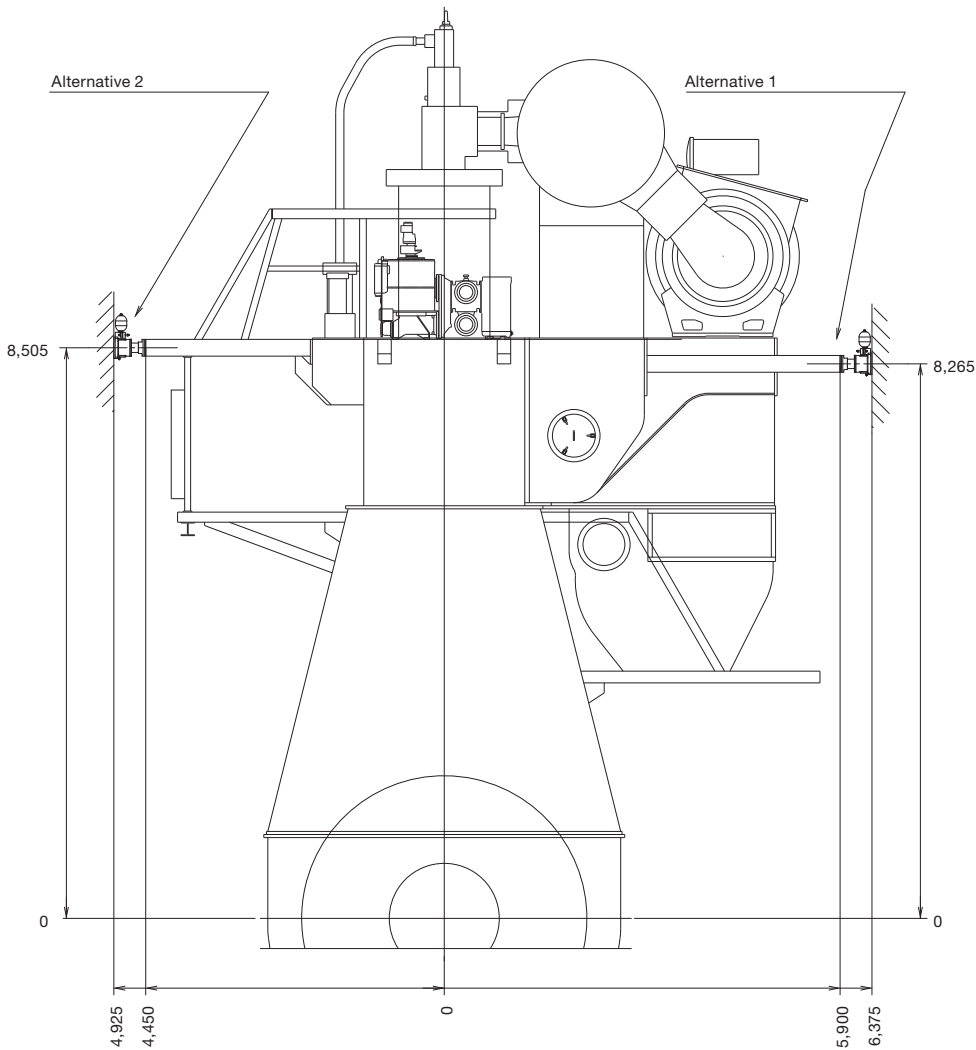

179 62 77-8.0.0

Fig. 5.15.01: Hydraulic top bracing data for 8G95ME-C9 with 2xTCA88 turbochargers

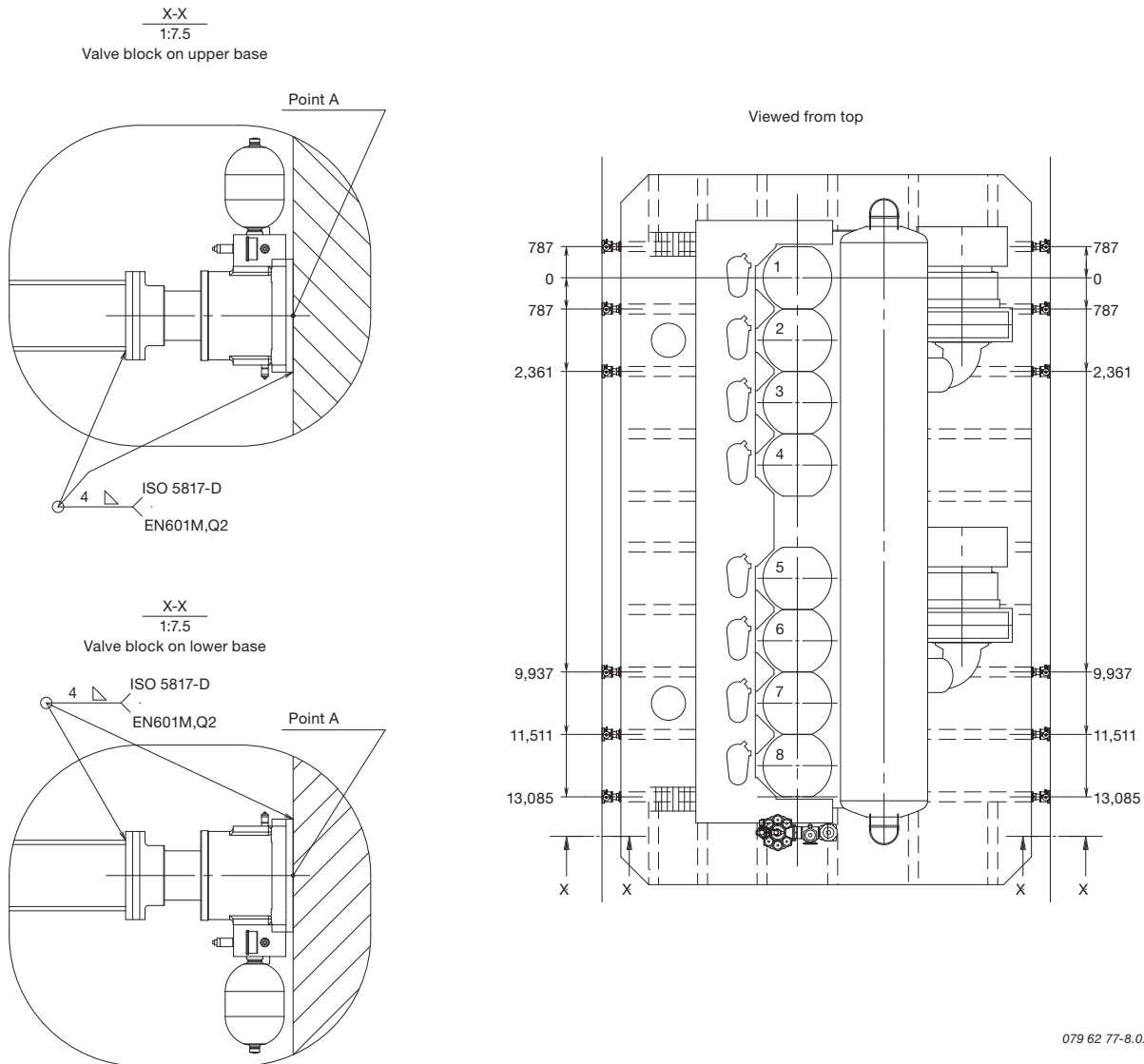

As the rigidity of the casing structure to which the top bracing is attached is most important, it is recommended that the top bracing is attached directly into a deck.

Required rigidity of the casing side point A:

In the axial direction of the hydraulic top bracing:  
Force per bracing: 127 kN

Max. corresponding deflection of casing side: 0.51 mm

In the horizontal and vertical direction of the hydraulic top bracing:  
Force per bracing: 22 kN

Max. corresponding deflection of casing side : 2.00 mm

Fig. 5.15.01: Hydraulic top bracing data



### Components for Engine Control System

#### Installation of ECS in the Engine Control Room

The following items are to be installed in the ECR (Engine Control Room):

- 2 pcs EICU (Engine Interface Control Unit)  
(1 pcs only for ME-B engines)
- 1 pcs MOP A (Main Operating Panel)  
EC-MOP with touch display, 15"  
or  
Touch display, 15"  
PC unit with pointing device for MOP
- 1 pcs MOP B  
EC-MOP with touch display, 15"  
or  
Touch display, 15"  
PC unit with keyboard and pointing device
- 1 pcs PMI/CoCoS system software  
Display, 19"  
PC unit
- 1 pcs Printer (Yard supply)
- 1 pcs Ethernet Switch and VPN router with firewall

The EICU functions as an interface unit to ECR related systems such as AMS (Alarm and Monitoring System), RCS (Remote Control System) and Safety System. On ME-B engines the EICU also controls the HPS.

MOP A and B are redundant and are the operator's interface to the ECS. Via both MOPs, the operator can control and view the status of the ECS. Via the PMI/CoCoS PC, the operator can view the status and operating history of the ECS and the engine.

The PMI Auto-tuning application is run on a standard PC. The PMI Auto-tuning system is used to optimize the combustion process with minimal operator attendance and improve the efficiency of the engine. See Section 18.02.

CoCoS-EDS ME Basic is included as part of the standard software package installed on the PMI/CoCoS PC. Optionally, the full version of CoCoS-EDS may be purchased separately. See Section 18.03.

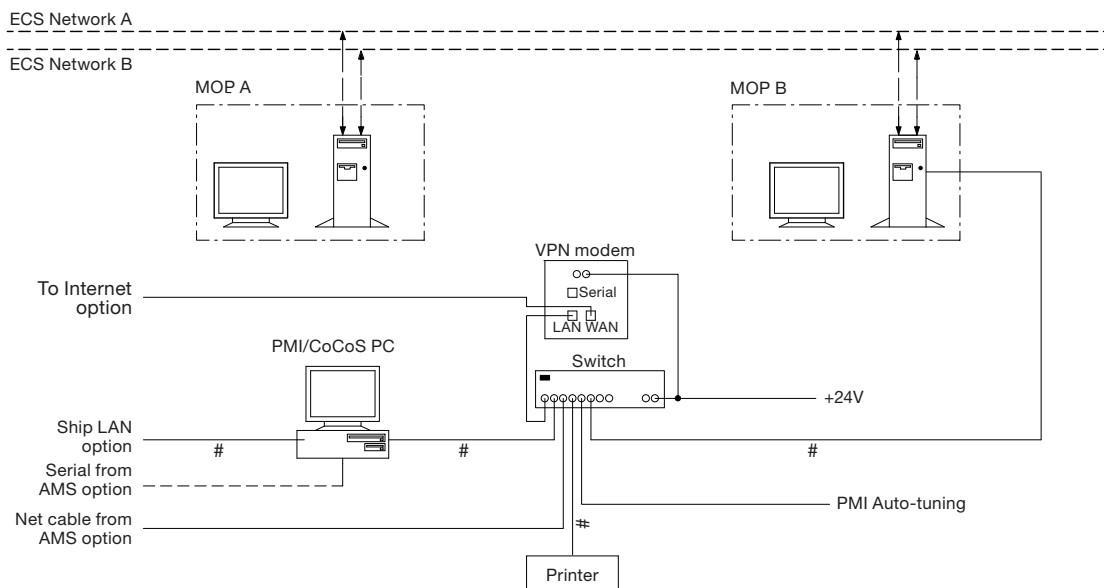

Abbreviation:

- PDB: Power Distribution Box
- UPS: Uninterruptible Power Supply
- PMI: Pressure Indicator
- CoCos-EDS: Computer Controlled Surveillance-Engine Diagnostics System
- AMS: Alarm Monitoring Systems

# Yard Supply

# Ethernet, supply with switch, cable length 10 metres  
Type: RJ45, STP (Shielded TwistedPair), CAT 5  
In case that 10 metre cable is not enough, this becomes Yard supply.

078 74 78-1.3a

Fig. 5.16.01 Network and PC components for the ME/ME-B Engine Control System



**EC-MOP**

- Integrated PC unit and touch display
  - Direct dimming control (0-100%)
  - USB connections at front
  - IP54 resistant front

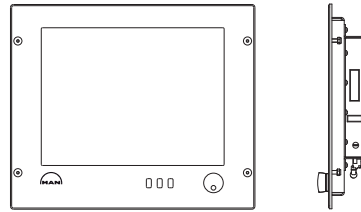

188 24 67-5.5.0

**MOP PC**

- MOP control unit
- Without display

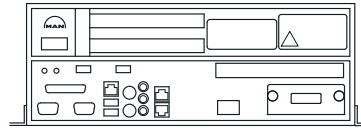

188 18 66-0.2.0

**Main operating panel (Display)**

- LCD (TFT) monitor 15" with touch display (calibrated)
  - Direct dimming control (0-100%)
  - USB connection at front
  - IP54 resistant front

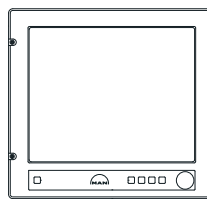

188 21 31-9.1.0

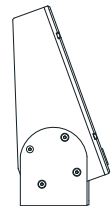
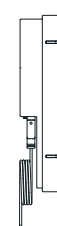

188 11 23-1.4.0

**Pointing device**

- Keyboard model
  - UK version, 104 keys
  - USB connection
- Trackball mouse
  - USB connection

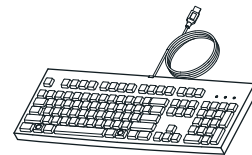

188 21 61-8.3.0



188 21 59-6.2.0

**PMI/CoCos Display**

- LCD (TFT) monitor 19"
  - Active matrix
  - Resolution 1,280x1,024, auto scaling
  - Direct dimming control (0-100%)
  - IP65 resistant front

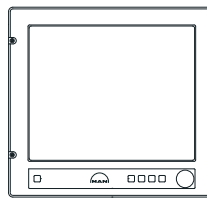

188 15 30-4.2.0

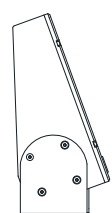

511 96 44-2.1.0

**PMI/CoCos PC**

- Standard industry PC with MS Windows operating system, UK version



178 62 31-3.0

**Router**

- Ethernet switch and VPN router with firewall

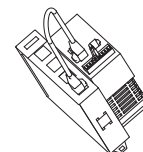

188 23 04-6.1.0

Fig. 5.16.02 MOP PC equipment for the ME/ME-B Engine Control System



**Printer**

- Network printer, ink colour printer

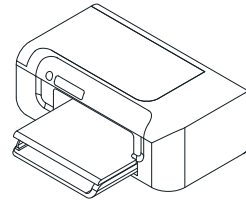

188 23 16-6.1.0

**EICU Cabinet**

- Engine interface control cabinet for ME-ECS for installation in ECR (recommended) or ER

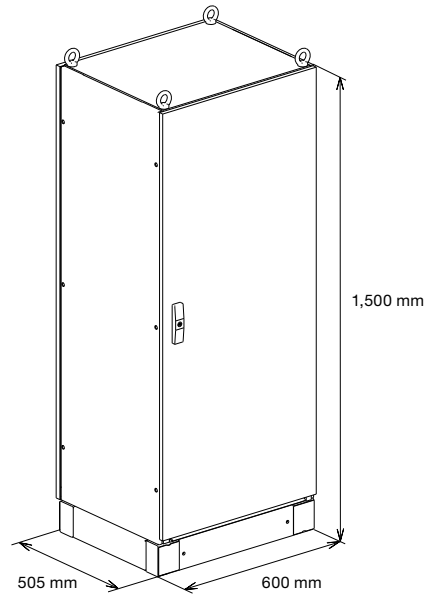

517 57 64-4.5.1

Fig. 5.16.03: The network printer and EICU cabinet unit for the ME Engine Control System

**Engine control room console**

- Recommended outline of Engine Control Room console with ME equipment

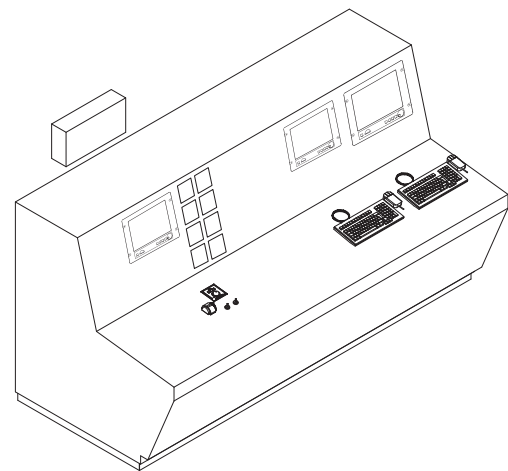
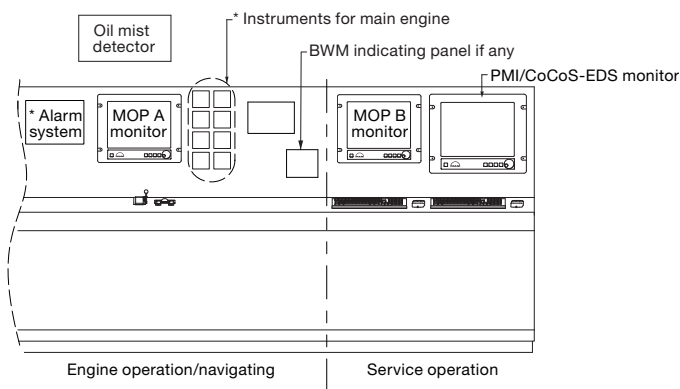

\* Yard supply

Oil mist detector equipment depending on supplier/maker  
BWM: Bearing Wear Monitoring

513 54 76-3.1.0

Fig. 5.16.04: Example of Engine Control Room console



## Shaftline Earthing Device

### Scope and field of application

A difference in the electrical potential between the hull and the propeller shaft will be generated due to the difference in materials and to the propeller being immersed in sea water.

In some cases, the difference in the electrical potential has caused spark erosion on the thrust, main bearings and journals of the crankshaft of the engine.

In order to reduce the electrical potential between the crankshaft and the hull and thus prevent spark erosion, a highly efficient shaftline earthing device must be installed.

The shaftline earthing device should be able to keep the electrical potential difference below 50 mV DC. A shaft-to-hull monitoring equipment with a mV-meter and with an output signal to the alarm system must be installed so that the potential and thus the correct function of the shaftline earthing device can be monitored.

Note that only one shaftline earthing device is needed in the propeller shaft system.

### Design description

The shaftline earthing device consists of two silver slip rings, two arrangements for holding brushes including connecting cables and monitoring equipment with a mV-meter and an output signal for alarm.

The slip rings should be made of solid silver or back-up rings of copper with a silver layer all over. The expected life span of the silver layer on the slip rings should be minimum 5 years.

The brushes should be made of minimum 80% silver and 20% graphite to ensure a sufficient electrical conducting capability.

Resistivity of the silver should be less than  $0.1\mu$  Ohm x m. The total resistance from the shaft to the hull must not exceed 0.001 Ohm.

Cabling of the shaftline earthing device to the hull must be with a cable with a cross section not less than  $45\text{ mm}^2$ . The length of the cable to the hull should be as short as possible.

Monitoring equipment should have a 4-20 mA signal for alarm and a mV-meter with a switch for changing range. Primary range from 0 to 50 mV DC and secondary range from 0 to 300 mV DC.

When the shaftline earthing device is working correctly, the electrical potential will normally be within the range of 10-50 mV DC depending of propeller size and revolutions.

The alarm set-point should be 80 mV for a high alarm. The alarm signals with an alarm delay of 30 seconds and an alarm cut-off, when the engine is stopped, must be connected to the alarm system.

Connection of cables is shown in the sketch, see Fig. 5.17.01.

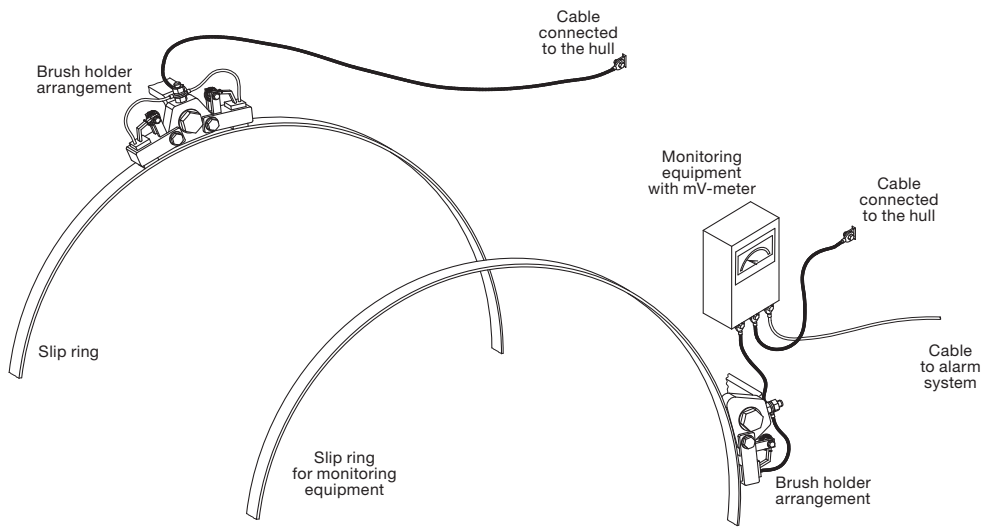

079 21 82-1.3.1.0

Fig. 5.17.01: Connection of cables for the shaftline earthing device

### Shaftline earthing device installations

The shaftline earthing device slip rings must be mounted on the foremost intermediate shaft as close to the engine as possible, see Fig. 5.17.02

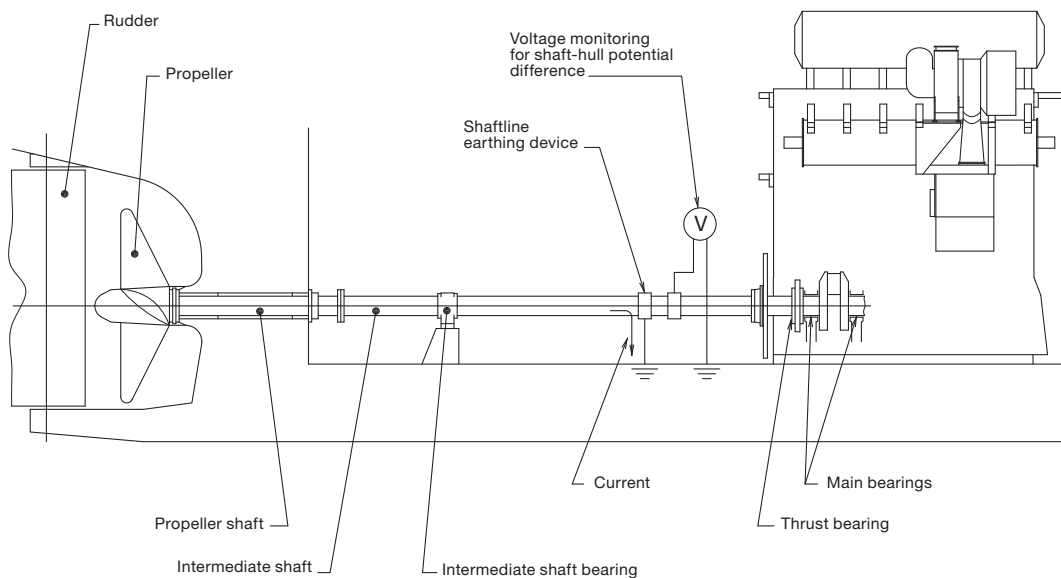

079 21 82-1.3.2.0

Fig. 5.17.02: Installation of shaftline earthing device in an engine plant without shaft-mounted generator





When a generator is fitted in the propeller shaft system, where the rotor of the generator is part of the intermediate shaft, the shaftline earthing device must be mounted between the generator and the engine, see Fig. 5.17.03

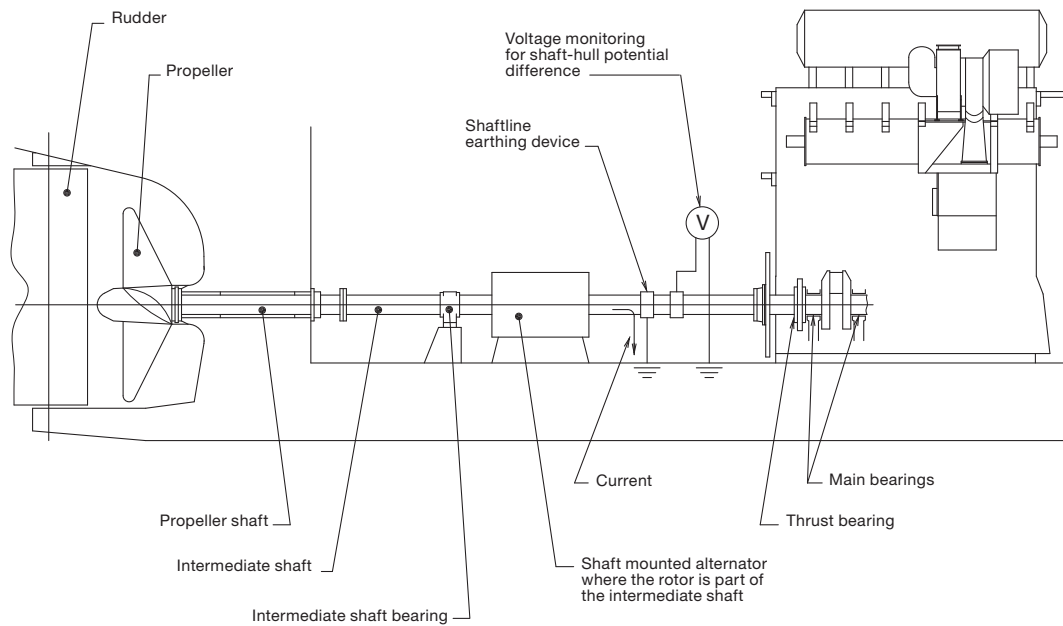

079 21 82-1.3.3.0

Fig. 5.17.03: Installation of shaftline earthing device in an engine plant with shaft-mounted generator



**MAN Alpha Controllable Pitch Propeller and Alphasonic Propulsion Control**

**This section is not applicable**



**MAN B&W**

---

---

# List of Capacities: Pumps, Coolers & Exhaust Gas

**6**

---

---

**MAN Diesel**



## Calculation of List of Capacities and Exhaust Gas Data

Updated engine and capacities data is available from the CEAS program on [www.marine.man.eu](http://www.marine.man.eu) → 'Two-Stroke' → 'CEAS Engine Calculations'.

This chapter describes the necessary auxiliary machinery capacities to be used for a nominally rated engine. The capacities given are valid for seawater cooling system and central cooling water system, respectively. For derated engine, i.e. with a specified MCR different from the nominally rated MCR

point, the list of capacities will be different from the nominal capacities.

Furthermore, among others, the exhaust gas data depends on the ambient temperature conditions.

Based on examples for a derated engine, the way of how to calculate the derated capacities, freshwater production and exhaust gas amounts and temperatures will be described in details.

## Nomenclature

In the following description and examples of the auxiliary machinery capacities, freshwater generator production and exhaust gas data, the below nomenclatures are used:

Engine ratings	Point / Index	Power	Speed
Nominal MCR point	$L_1$	$P_{L_1}$	$n_{L_1}$
Specified MCR point	M	$P_M$	$n_M$
Service point	S	$P_S$	$n_S$

Fig. 6.01.01: Nomenclature of basic engine ratings

Parameters	Cooler index	Flow index
Q = Heat dissipation	air scavenge air cooler	sw seawater flow
V = Volume flow	lub lube oil cooler	cw cooling/central water flow
M = Mass flow	jw jacket water cooler	exh exhaust gas
T = Temperature	cent central cooler	fw freshwater

Fig. 6.01.02: Nomenclature of coolers and volume flows, etc.

## Engine configurations related to SFOC

The engine type is available in the following version only with respect to the efficiency of the turbocharger:

**With high efficiency turbocharger**, which is the basic design and for which the lists of capacities Section 6.03 are calculated.



## List of Capacities for 5G95ME-C9.5-TII at NMCR

	Seawater cooling						Central cooling									
	Conventional TC			High eff. TC			Conventional TC			High eff. TC						
	2 x TCA77-21	2 x A275-L	2 x MET71-MB	2 x TCA77-21	2 x A275-L	2 x MET71-MB	2 x TCA77-21	2 x A275-L	2 x MET71-MB	2 x TCA77-21	2 x A275-L	2 x MET71-MB				
<b>Pumps</b>																
Fuel oil circulation	m <sup>3</sup> /h	15.1	15.1	15.1	15.0	15.0	15.0	15.1	15.1	15.1	15.0	15.0	15.0	15.0	15.0	15.0
Fuel oil supply	m <sup>3</sup> /h	9.1	9.1	9.1	9.1	9.1	9.1	9.2	9.2	9.2	9.1	9.1	9.1	9.1	9.1	9.1
Jacket cooling	m <sup>3</sup> /h	240	240	240	240	240	240	240	240	240	240	240	240	240	240	240
Seawater cooling *	m <sup>3</sup> /h	1010	1010	1030	1030	1030	1050	960	960	970	990	990	990	990	990	990
Main lubrication oil *	m <sup>3</sup> /h	600	590	600	600	590	600	600	590	600	600	590	600	600	590	600
Central cooling *	m <sup>3</sup> /h	-	-	-	-	-	-	770	780	790	790	800	800	810	810	810
<b>Scavenge air cooler(s)</b>																
Heat diss. app.	kW	12,380	12,380	12,380	12,930	12,930	12,930	12,350	12,350	12,350	12,900	12,900	12,900	12,900	12,900	12,900
Central water flow	m <sup>3</sup> /h	-	-	-	-	-	-	440	440	440	460	460	460	460	460	460
Seawater flow	m <sup>3</sup> /h	610	610	610	630	630	630	-	-	-	-	-	-	-	-	-
<b>Lubricating oil cooler</b>																
Heat diss. app. *	kW	2,700	2,730	2,840	2,700	2,730	2,840	2,700	2,740	2,840	2,700	2,740	2,840	2,840	2,840	2,840
Lube oil flow *	m <sup>3</sup> /h	600	590	600	600	590	600	600	590	600	600	590	600	600	600	600
Central water flow	m <sup>3</sup> /h	-	-	-	-	-	-	330	340	350	330	340	350	350	350	350
Seawater flow	m <sup>3</sup> /h	400	400	420	400	400	420	-	-	-	-	-	-	-	-	-
<b>Jacket water cooler</b>																
Heat diss. app.	kW	4,600	4,600	4,600	4,570	4,570	4,570	4,610	4,610	4,610	4,580	4,580	4,580	4,580	4,580	4,580
Jacket water flow	m <sup>3</sup> /h	240	240	240	240	240	240	240	240	240	240	240	240	240	240	240
Central water flow	m <sup>3</sup> /h	-	-	-	-	-	-	330	340	350	330	340	350	350	350	350
Seawater flow	m <sup>3</sup> /h	400	400	420	400	400	420	-	-	-	-	-	-	-	-	-
<b>Central cooler</b>																
Heat diss. app. *	kW	-	-	-	-	-	-	19,660	19,700	19,800	20,180	20,220	20,320	20,320	20,320	20,320
Central water flow	m <sup>3</sup> /h	-	-	-	-	-	-	770	780	790	790	800	810	810	810	810
Seawater flow	m <sup>3</sup> /h	-	-	-	-	-	-	960	960	970	990	990	990	990	990	990
<b>Starting air system, 30.0 bar g, 12 starts. Fixed pitch propeller - reversible engine</b>																
Receiver volume	m <sup>3</sup>	2 x 16.5	2 x 16.5	2 x 16.5	2 x 16.5	2 x 16.5	2 x 16.5	2 x 16.5	2 x 16.5	2 x 16.5	2 x 16.5	2 x 16.5	2 x 16.5	2 x 16.5	2 x 16.5	2 x 16.5
Compressor cap.	m <sup>3</sup>	990	990	990	990	990	990	990	990	990	990	990	990	990	990	990
<b>Starting air system, 30.0 bar g, 6 starts. Controllable pitch propeller - non-reversible engine</b>																
Receiver volume	m <sup>3</sup>	2 x 9.0	2 x 9.0	2 x 9.0	2 x 9.0	2 x 9.0	2 x 9.0	2 x 9.0	2 x 9.0	2 x 9.0	2 x 9.0	2 x 9.0	2 x 9.0	2 x 9.0	2 x 9.0	2 x 9.0
Compressor cap.	m <sup>3</sup>	540	540	540	540	540	540	540	540	540	540	540	540	540	540	540
<b>Other values</b>																
Fuel oil heater	kW	268	268	268	267	267	267	269	269	269	267	267	267	267	267	267
Exh. gas temp. **	°C	260	260	260	240	240	240	260	260	260	240	240	240	240	240	240
Exh. gas amount **	kg/h	256,490	256,490	256,490	273,630	273,630	273,630	256,490	256,490	256,490	273,630	273,630	273,630	273,630	273,630	273,630
Air consumption **	kg/s	63.6	63.6	63.6	67.9	67.9	67.9	64.1	64.1	64.1	68.5	68.5	68.5	68.5	68.5	68.5

\* For main engine arrangements with built-on power take-off (PTO) of a MAN Diesel & Turbo recommended type and/or torsional vibration damper the engine's capacities must be increased by those stated for the actual system

\*\* ISO based

For List of Capacities for derated engines and performance data at part load please visit <http://www.mandieselturbo.com/ceas/LOC>

Table 6.03.01e: Capacities for seawater and central systems as well as conventional and high efficiency turbochargers stated at NMCR



List of Capacities for 6G95ME-C9.5-TII at NMCR

	Seawater cooling						Central cooling					
	Conventional TC			High eff. TC			Conventional TC			High eff. TC		
	2 x TCA77-26	2 x A180-L37	2 x MET83-MB	2 x TCA88-21	2 x A280-L	2 x MET83-MB	2 x TCA77-26	2 x A180-L37	2 x MET83-MB	2 x TCA88-21	2 x A280-L	2 x MET83-MB
<b>Pumps</b>												
Fuel oil circulation	m³/h	18.1	18.1	18.1	18.0	18.0	18.0	18.1	18.1	18.1	18.1	18.1
Fuel oil supply	m³/h	11.0	11.0	11.0	10.9	10.9	10.9	11.0	11.0	11.0	10.9	10.9
Jacket cooling	m³/h	290	290	290	290	290	290	290	290	290	290	290
Seawater cooling *	m³/h	1200	1210	1230	1240	1240	1260	1150	1160	1160	1180	1190
Main lubrication oil *	m³/h	680	680	690	700	680	690	680	680	690	700	680
Central cooling *	m³/h	-	-	-	-	-	-	920	940	950	960	970
<b>Scavenge air cooler(s)</b>												
Heat diss. app.	kW	14,860	14,860	14,860	15,520	15,520	15,520	14,820	14,820	14,820	15,480	15,480
Central water flow	m³/h	-	-	-	-	-	-	530	530	530	560	560
Seawater flow	m³/h	730	730	730	760	760	760	-	-	-	-	-
<b>Lubricating oil cooler</b>												
Heat diss. app. *	kW	3,200	3,290	3,420	3,250	3,290	3,420	3,210	3,300	3,430	3,260	3,300
Lube oil flow *	m³/h	680	680	690	700	680	690	680	680	690	700	680
Central water flow	m³/h	-	-	-	-	-	-	390	410	420	400	410
Seawater flow	m³/h	470	480	500	480	480	500	-	-	-	-	-
<b>Jacket water cooler</b>												
Heat diss. app.	kW	5,510	5,510	5,510	5,480	5,480	5,480	5,530	5,530	5,530	5,490	5,490
Jacket water flow	m³/h	290	290	290	290	290	290	290	290	290	290	290
Central water flow	m³/h	-	-	-	-	-	-	390	410	420	400	410
Seawater flow	m³/h	470	480	500	480	480	500	-	-	-	-	-
<b>Central cooler</b>												
Heat diss. app. *	kW	-	-	-	-	-	-	23,560	23,650	23,780	24,230	24,270
Central water flow	m³/h	-	-	-	-	-	-	920	940	950	960	970
Seawater flow	m³/h	-	-	-	-	-	-	1,150	1,160	1,160	1,180	1,190
<b>Starting air system, 30.0 bar g, 12 starts. Fixed pitch propeller - reversible engine</b>												
Receiver volume	m³	2 x 18.0	2 x 18.0	2 x 18.0	2 x 18.0	2 x 18.0	2 x 18.0	2 x 18.0	2 x 18.0	2 x 18.0	2 x 18.0	2 x 18.0
Compressor cap.	m³	1,080	1,080	1,080	1,080	1,080	1,080	1,080	1,080	1,080	1,080	1,080
<b>Starting air system, 30.0 bar g, 6 starts. Controllable pitch propeller - non-reversible engine</b>												
Receiver volume	m³	2 x 9.5	2 x 9.5	2 x 9.5	2 x 9.5	2 x 9.5	2 x 9.5	2 x 9.5	2 x 9.5	2 x 9.5	2 x 9.5	2 x 9.5
Compressor cap.	m³	570	570	570	570	570	570	570	570	570	570	570
<b>Other values</b>												
Fuel oil heater	kW	322	322	322	320	320	320	323	323	323	321	321
Exh. gas temp. **	°C	260	260	260	240	240	240	260	260	260	240	240
Exh. gas amount **	kg/h	307,790	307,790	307,790	328,360	328,360	328,360	307,790	307,790	307,790	328,360	328,360
Air consumption **	kg/s	76.3	76.3	76.3	81.5	81.5	81.5	77.0	77.0	77.0	82.2	82.2

\* For main engine arrangements with built-on power take-off (PTO) of a MAN Diesel & Turbo recommended type and/or torsional vibration damper the engine's capacities must be increased by those stated for the actual system

\*\* ISO based

For List of Capacities for derated engines and performance data at part load please visit <http://www.mandieselturbo.com/ceas/LOC>

Table 6.03.01f: Capacities for seawater and central systems as well as conventional and high efficiency turbochargers stated at NMCR



List of Capacities for 7G95ME-C9.5-TII at NMCR

	Seawater cooling						Central cooling						
	Conventional TC			High eff. TC			Conventional TC			High eff. TC			
	2 x TCA88-21	2 x A280-L	2 x MET83-MB	2 x TCA88-21	2 x A185-L37	2 x MET83-MB	2 x TCA88-21	2 x A280-L	2 x MET83-MB	2 x TCA88-21	2 x A185-L37	2 x MET83-MB	
<b>Pumps</b>													
Fuel oil circulation	m³/h	21.1	21.1	21.1	21.0	21.0	21.0	21.2	21.2	21.2	21.1	21.1	21.1
Fuel oil supply	m³/h	12.8	12.8	12.8	12.7	12.7	12.7	12.8	12.8	12.8	12.7	12.7	12.7
Jacket cooling	m³/h	340	340	340	330	330	330	340	340	340	330	330	330
Seawater cooling *	m³/h	1400	1410	1430	1430	1440	1460	1340	1350	1350	1380	1380	1390
Main lubrication oil *	m³/h	780	760	770	780	760	770	780	760	770	780	760	770
Central cooling *	m³/h	-	-	-	-	-	-	1,080	1,090	1,100	1,110	1,120	1,130
<b>Scavenge air cooler(s)</b>													
Heat diss. app.	kW	17,330	17,330	17,330	18,110	18,110	18,110	17,290	17,290	17,290	18,060	18,060	18,060
Central water flow	m³/h	-	-	-	-	-	-	620	620	620	650	650	650
Seawater flow	m³/h	850	850	850	880	880	880	-	-	-	-	-	-
<b>Lubricating oil cooler</b>													
Heat diss. app. *	kW	3,750	3,800	3,930	3,750	3,850	3,930	3,760	3,810	3,940	3,760	3,860	3,940
Lube oil flow *	m³/h	780	760	770	780	760	770	780	760	770	780	760	770
Central water flow	m³/h	-	-	-	-	-	-	460	470	480	460	470	480
Seawater flow	m³/h	550	560	580	550	560	580	-	-	-	-	-	-
<b>Jacket water cooler</b>													
Heat diss. app.	kW	6,430	6,430	6,430	6,390	6,390	6,390	6,450	6,450	6,450	6,410	6,410	6,410
Jacket water flow	m³/h	340	340	340	330	330	330	340	340	340	330	330	330
Central water flow	m³/h	-	-	-	-	-	-	460	470	480	460	470	480
Seawater flow	m³/h	550	560	580	550	560	580	-	-	-	-	-	-
<b>Central cooler</b>													
Heat diss. app. *	kW	-	-	-	-	-	-	27,500	27,550	27,680	28,230	28,330	28,410
Central water flow	m³/h	-	-	-	-	-	-	1,080	1,090	1,100	1,110	1,120	1,130
Seawater flow	m³/h	-	-	-	-	-	-	1,340	1,350	1,350	1,380	1,380	1,390
<b>Starting air system, 30.0 bar g, 12 starts. Fixed pitch propeller - reversible engine</b>													
Receiver volume	m³	2 x 18.5	2 x 18.5	2 x 18.5	2 x 18.5	2 x 18.5	2 x 18.5	2 x 18.5	2 x 18.5	2 x 18.5	2 x 18.5	2 x 18.5	2 x 18.5
Compressor cap.	m³	1,110	1,110	1,110	1,110	1,110	1,110	1,110	1,110	1,110	1,110	1,110	1,110
<b>Starting air system, 30.0 bar g, 6 starts. Controllable pitch propeller - non-reversible engine</b>													
Receiver volume	m³	2 x 9.5	2 x 9.5	2 x 9.5	2 x 9.5	2 x 9.5	2 x 9.5	2 x 9.5	2 x 9.5	2 x 9.5	2 x 9.5	2 x 9.5	2 x 9.5
Compressor cap.	m³	570	570	570	570	570	570	570	570	570	570	570	570
<b>Other values</b>													
Fuel oil heater	kW	376	376	376	374	374	374	376	376	376	374	374	374
Exh. gas temp. **	°C	260	260	260	240	240	240	260	260	260	240	240	240
Exh. gas amount **	kg/h	359,090	359,090	359,090	383,080	383,080	383,080	359,090	359,090	359,090	383,080	383,080	383,080
Air consumption **	kg/s	89.0	89.0	89.0	95.1	95.1	95.1	89.8	89.8	89.8	95.9	95.9	95.9

\* For main engine arrangements with built-on power take-off (PTO) of a MAN Diesel & Turbo recommended type and/or torsional vibration damper the engine's capacities must be increased by those stated for the actual system

\*\* ISO based

For List of Capacities for derated engines and performance data at part load please visit <http://www.mandieselturbo.com/ceas/LOC>

Table 6.03.01g: Capacities for seawater and central systems as well as conventional and high efficiency turbochargers stated at NMCR



List of Capacities for 8G95ME-C9.5-TII at NMCR

	Seawater cooling						Central cooling						
	Conventional TC			High eff. TC			Conventional TC			High eff. TC			
	2 x TCA88-21	2 x A285-L	2 x MET90-MB	2 x TCA88-26	2 x A285-L	2 x MET90-MB	2 x TCA88-21	2 x A285-L	2 x MET90-MB	2 x TCA88-26	2 x A285-L	2 x MET90-MB	
<b>Pumps</b>													
Fuel oil circulation	m³/h	24.1	24.1	24.1	24.0	24.0	24.0	24.2	24.2	24.2	24.1	24.1	24.1
Fuel oil supply	m³/h	14.6	14.6	14.6	14.5	14.5	14.5	14.6	14.6	14.6	14.6	14.6	14.6
Jacket cooling	m³/h	380	380	380	380	380	380	380	380	380	380	380	380
Seawater cooling *	m³/h	1590	1610	1630	1630	1650	1670	1530	1540	1550	1580	1580	1590
Main lubrication oil *	m³/h	860	850	860	860	850	860	860	850	860	860	850	860
Central cooling *	m³/h	-	-	-	-	-	-	1,240	1,250	1,270	1,270	1,280	1,300
<b>Scavenge air cooler(s)</b>													
Heat diss. app.	kW	19,810	19,810	19,810	20,690	20,690	20,690	19,770	19,770	19,770	20,640	20,640	20,640
Central water flow	m³/h	-	-	-	-	-	-	710	710	710	740	740	740
Seawater flow	m³/h	970	970	970	1,010	1,010	1,010	-	-	-	-	-	-
<b>Lubricating oil cooler</b>													
Heat diss. app. *	kW	4,260	4,360	4,520	4,260	4,360	4,520	4,270	4,370	4,530	4,270	4,370	4,530
Lube oil flow *	m³/h	860	850	860	860	850	860	860	850	860	860	850	860
Central water flow	m³/h	-	-	-	-	-	-	530	540	560	530	540	560
Seawater flow	m³/h	620	640	660	620	640	660	-	-	-	-	-	-
<b>Jacket water cooler</b>													
Heat diss. app.	kW	7,350	7,350	7,350	7,310	7,310	7,310	7,370	7,370	7,370	7,330	7,330	7,330
Jacket water flow	m³/h	380	380	380	380	380	380	380	380	380	380	380	380
Central water flow	m³/h	-	-	-	-	-	-	530	540	560	530	540	560
Seawater flow	m³/h	620	640	660	620	640	660	-	-	-	-	-	-
<b>Central cooler</b>													
Heat diss. app. *	kW	-	-	-	-	-	-	31,410	31,510	31,670	32,240	32,340	32,500
Central water flow	m³/h	-	-	-	-	-	-	1,240	1,250	1,270	1,270	1,280	1,300
Seawater flow	m³/h	-	-	-	-	-	-	1,530	1,540	1,550	1,580	1,580	1,590
<b>Starting air system, 30.0 bar g, 12 starts. Fixed pitch propeller - reversible engine</b>													
Receiver volume	m³	2 x 18.5	2 x 18.5	2 x 18.5	2 x 18.5	2 x 18.5	2 x 18.5	2 x 18.5	2 x 18.5	2 x 18.5	2 x 18.5	2 x 18.5	2 x 18.5
Compressor cap.	m³	1,110	1,110	1,110	1,110	1,110	1,110	1,110	1,110	1,110	1,110	1,110	1,110
<b>Starting air system, 30.0 bar g, 6 starts. Controllable pitch propeller - non-reversible engine</b>													
Receiver volume	m³	2 x 10.0	2 x 10.0	2 x 10.0	2 x 10.0	2 x 10.0	2 x 10.0	2 x 10.0	2 x 10.0	2 x 10.0	2 x 10.0	2 x 10.0	2 x 10.0
Compressor cap.	m³	600	600	600	600	600	600	600	600	600	600	600	600
<b>Other values</b>													
Fuel oil heater	kW	429	429	429	427	427	427	430	430	430	428	428	428
Exh. gas temp. **	°C	260	260	260	240	240	240	260	260	260	240	240	240
Exh. gas amount **	kg/h	410,390	410,390	410,390	437,810	437,810	437,810	410,390	410,390	410,390	437,810	437,810	437,810
Air consumption **	kg/s	101.7	101.7	101.7	108.7	108.7	108.7	102.6	102.6	102.6	109.6	109.6	109.6

\* For main engine arrangements with built-on power take-off (PTO) of a MAN Diesel & Turbo recommended type and/or torsional vibration damper the engine's capacities must be increased by those stated for the actual system

\*\* ISO based

For List of Capacities for derated engines and performance data at part load please visit <http://www.mandieselturbo.com/ceas/LOC>

Table 6.03.01h: Capacities for seawater and central systems as well as conventional and high efficiency turbochargers stated at NMCR





## List of Capacities for 9G95ME-C9.5-TII at NMCR

	Seawater cooling						Central cooling						
	Conventional TC			High eff. TC			Conventional TC			High eff. TC			
	3 x TCA77-26	2 x A190-L37	2 x MET90-MB	3 x TCA88-21	3 x A280-L	3 x MET83-MB	3 x TCA77-26	2 x A190-L37	2 x MET90-MB	3 x TCA88-21	3 x A280-L	3 x MET83-MB	
<b>Pumps</b>													
Fuel oil circulation	m <sup>3</sup> /h	27.1	27.1	27.1	27.0	27.0	27.0	27.2	27.2	27.2	27.1	27.1	27.1
Fuel oil supply	m <sup>3</sup> /h	16.4	16.4	16.4	16.3	16.3	16.3	16.5	16.5	16.5	16.4	16.4	16.4
Jacket cooling	m <sup>3</sup> /h	430	430	430	430	430	430	430	430	430	430	430	430
Seawater cooling *	m <sup>3</sup> /h	1790	1810	1830	1850	1860	1890	1730	1730	1740	1780	1780	1790
Main lubrication oil *	m <sup>3</sup> /h	960	940	950	970	940	960	960	940	950	970	940	960
Central cooling *	m <sup>3</sup> /h	-	-	-	-	-	-	1,390	1,410	1,420	1,430	1,440	1,460
<b>Scavenge air cooler(s)</b>													
Heat diss. app.	kW	22,290	22,290	22,290	23,280	23,280	23,280	22,240	22,240	22,240	23,220	23,220	23,220
Central water flow	m <sup>3</sup> /h	-	-	-	-	-	-	800	800	800	830	830	830
Seawater flow	m <sup>3</sup> /h	1,090	1,090	1,090	1,140	1,140	1,140	-	-	-	-	-	-
<b>Lubricating oil cooler</b>													
Heat diss. app. *	kW	4,810	4,920	5,020	4,870	4,930	5,130	4,820	4,930	5,030	4,880	4,950	5,140
Lube oil flow *	m <sup>3</sup> /h	960	940	950	970	940	960	960	940	950	970	940	960
Central water flow	m <sup>3</sup> /h	-	-	-	-	-	-	590	610	620	600	610	630
Seawater flow	m <sup>3</sup> /h	700	720	740	710	720	750	-	-	-	-	-	-
<b>Jacket water cooler</b>													
Heat diss. app.	kW	8,270	8,270	8,270	8,220	8,220	8,220	8,290	8,290	8,290	8,240	8,240	8,240
Jacket water flow	m <sup>3</sup> /h	430	430	430	430	430	430	430	430	430	430	430	430
Central water flow	m <sup>3</sup> /h	-	-	-	-	-	-	590	610	620	600	610	630
Seawater flow	m <sup>3</sup> /h	700	720	740	710	720	750	-	-	-	-	-	-
<b>Central cooler</b>													
Heat diss. app. *	kW	-	-	-	-	-	-	35,350	35,460	35,560	36,340	36,410	36,600
Central water flow	m <sup>3</sup> /h	-	-	-	-	-	-	1,390	1,410	1,420	1,430	1,440	1,460
Seawater flow	m <sup>3</sup> /h	-	-	-	-	-	-	1,730	1,730	1,740	1,780	1,780	1,790
<b>Starting air system, 30.0 bar g, 12 starts. Fixed pitch propeller - reversible engine</b>													
Receiver volume	m <sup>3</sup>	2 x 19.0	2 x 19.0	2 x 19.0	2 x 19.0	2 x 19.0	2 x 19.0	2 x 19.0	2 x 19.0	2 x 19.0	2 x 19.0	2 x 19.0	2 x 19.0
Compressor cap.	m <sup>3</sup>	1,140	1,140	1,140	1,140	1,140	1,140	1,140	1,140	1,140	1,140	1,140	1,140
<b>Starting air system, 30.0 bar g, 6 starts. Controllable pitch propeller - non-reversible engine</b>													
Receiver volume	m <sup>3</sup>	2 x 10.0	2 x 10.0	2 x 10.0	2 x 10.0	2 x 10.0	2 x 10.0	2 x 10.0	2 x 10.0	2 x 10.0	2 x 10.0	2 x 10.0	2 x 10.0
Compressor cap.	m <sup>3</sup>	600	600	600	600	600	600	600	600	600	600	600	600
<b>Other values</b>													
Fuel oil heater	kW	483	483	483	480	480	480	484	484	484	481	481	481
Exh. gas temp. **	°C	260	260	260	240	240	240	260	260	260	240	240	240
Exh. gas amount **	kg/h	461,680	461,680	461,680	492,540	492,540	492,540	461,680	461,680	461,680	492,540	492,540	492,540
Air consumption **	kg/s	114.4	114.4	114.4	122.2	122.2	122.2	115.4	115.4	115.4	123.4	123.4	123.4

\* For main engine arrangements with built-on power take-off (PTO) of a MAN Diesel & Turbo recommended type and/or torsional vibration damper the engine's capacities must be increased by those stated for the actual system

\*\* ISO based

For List of Capacities for derated engines and performance data at part load please visit <http://www.mandieselturbo.com/ceas/LOC>

Table 6.03.01i: Capacities for seawater and central systems as well as conventional and high efficiency turbochargers stated at NMCR



List of Capacities for 10G95ME-C9.5-TII at NMCR

	Seawater cooling						Central cooling						
	Conventional TC			High eff. TC			Conventional TC			High eff. TC			
	3 x TCA88-21	3 x A280-L	3 x MET83-MB	3 x TCA88-21	3 x A280-L	3 x MET83-MB	3 x TCA88-21	3 x A280-L	3 x MET83-MB	3 x TCA88-21	3 x A280-L	3 x MET83-MB	
<b>Pumps</b>													
Fuel oil circulation	m³/h	30.2	30.2	30.2	30.0	30.0	30.0	30.2	30.2	30.2	30.1	30.1	30.1
Fuel oil supply	m³/h	18.3	18.3	18.3	18.2	18.2	18.2	18.3	18.3	18.3	18.2	18.2	18.2
Jacket cooling	m³/h	480	480	480	480	480	480	480	480	480	480	480	480
Seawater cooling *	m³/h	2000	2010	2040	2050	2060	2090	1920	1920	1930	1970	1970	1980
Main lubrication oil *	m³/h	1060	1030	1040	1060	1030	1040	1060	1030	1040	1060	1030	1040
Central cooling *	m³/h	-	-	-	-	-	-	1,550	1,560	1,580	1,590	1,600	1,620
<b>Scavenge air cooler(s)</b>													
Heat diss. app.	kW	24,760	24,760	24,760	25,870	25,870	25,870	24,710	24,710	24,710	25,790	25,790	25,790
Central water flow	m³/h	-	-	-	-	-	-	890	890	890	930	930	930
Seawater flow	m³/h	1,210	1,210	1,210	1,260	1,260	1,260	-	-	-	-	-	-
<b>Lubricating oil cooler</b>													
Heat diss. app. *	kW	5,380	5,440	5,640	5,380	5,440	5,640	5,390	5,450	5,650	5,390	5,450	5,650
Lube oil flow *	m³/h	1,060	1,030	1,040	1,060	1,030	1,040	1,060	1,030	1,040	1,060	1,030	1,040
Central water flow	m³/h	-	-	-	-	-	-	660	670	690	660	670	690
Seawater flow	m³/h	790	800	830	790	800	830	-	-	-	-	-	-
<b>Jacket water cooler</b>													
Heat diss. app.	kW	9,190	9,190	9,190	9,140	9,140	9,140	9,210	9,210	9,210	9,160	9,160	9,160
Jacket water flow	m³/h	480	480	480	480	480	480	480	480	480	480	480	480
Central water flow	m³/h	-	-	-	-	-	-	660	670	690	660	670	690
Seawater flow	m³/h	790	800	830	790	800	830	-	-	-	-	-	-
<b>Central cooler</b>													
Heat diss. app. *	kW	-	-	-	-	-	-	39,310	39,370	39,570	40,340	40,400	40,600
Central water flow	m³/h	-	-	-	-	-	-	1,550	1,560	1,580	1,590	1,600	1,620
Seawater flow	m³/h	-	-	-	-	-	-	1,920	1,920	1,930	1,970	1,970	1,980
<b>Starting air system, 30.0 bar g, 12 starts. Fixed pitch propeller - reversible engine</b>													
Receiver volume	m³	2 x 19.0	2 x 19.0	2 x 19.0	2 x 19.0	2 x 19.0	2 x 19.0	2 x 19.0	2 x 19.0	2 x 19.0	2 x 19.0	2 x 19.0	2 x 19.0
Compressor cap.	m³	1,140	1,140	1,140	1,140	1,140	1,140	1,140	1,140	1,140	1,140	1,140	1,140
<b>Starting air system, 30.0 bar g, 6 starts. Controllable pitch propeller - non-reversible engine</b>													
Receiver volume	m³	2 x 10.0	2 x 10.0	2 x 10.0	2 x 10.0	2 x 10.0	2 x 10.0	2 x 10.0	2 x 10.0	2 x 10.0	2 x 10.0	2 x 10.0	2 x 10.0
Compressor cap.	m³	600	600	600	600	600	600	600	600	600	600	600	600
<b>Other values</b>													
Fuel oil heater	kW	537	537	537	534	534	534	538	538	538	535	535	535
Exh. gas temp. **	°C	260	260	260	240	240	240	260	260	260	240	240	240
Exh. gas amount **	kg/h	512,980	512,980	512,980	547,260	547,260	547,260	512,980	512,980	512,980	547,260	547,260	547,260
Air consumption **	kg/s	127.1	127.1	127.1	135.8	135.8	135.8	128.3	128.3	128.3	137.1	137.1	137.1

\* For main engine arrangements with built-on power take-off (PTO) of a MAN Diesel & Turbo recommended type and/or torsional vibration damper the engine's capacities must be increased by those stated for the actual system

\*\* ISO based

For List of Capacities for derated engines and performance data at part load please visit <http://www.mandieselturbo.com/ceas/LOC>

Table 6.03.01j: Capacities for seawater and central systems as well as conventional and high efficiency turbochargers stated at NMCR



List of Capacities for 11G95ME-C9.5-TII at NMCR

	Seawater cooling						Central cooling						
	Conventional TC			High eff. TC			Conventional TC			High eff. TC			
	3 x TCA88-21	3 x A185-L37	3 x MET83-MB	3 x TCA88-21	3 x A285-L	3 x MET90-MB	3 x TCA88-21	3 x A185-L37	3 x MET83-MB	3 x TCA88-21	3 x A285-L	3 x MET90-MB	
<b>Pumps</b>													
Fuel oil circulation	m³/h	33.2	33.2	33.2	33.0	33.0	33.0	33.2	33.2	33.2	33.1	33.1	33.1
Fuel oil supply	m³/h	20.1	20.1	20.1	20.0	20.0	20.0	20.1	20.1	20.1	20.0	20.0	20.0
Jacket cooling	m³/h	530	530	530	520	520	520	530	530	530	530	530	530
Seawater cooling *	m³/h	2190	2210	2230	2250	2270	2310	2110	2120	2120	2170	2170	2190
Main lubrication oil *	m³/h	1140	1110	1130	1140	1110	1140	1140	1110	1130	1140	1110	1140
Central cooling *	m³/h	-	-	-	-	-	-	1,700	1,710	1,730	1,750	1,760	1,790
<b>Scavenge air cooler(s)</b>													
Heat diss. app.	kW	27,240	27,240	27,240	28,450	28,450	28,450	27,180	27,180	27,180	28,370	28,370	28,370
Central water flow	m³/h	-	-	-	-	-	-	970	970	970	1,020	1,020	1,020
Seawater flow	m³/h	1,330	1,330	1,330	1,390	1,390	1,390	-	-	-	-	-	-
<b>Lubricating oil cooler</b>													
Heat diss. app. *	kW	5,890	6,030	6,140	5,890	6,030	6,270	5,900	6,040	6,160	5,900	6,040	6,280
Lube oil flow *	m³/h	1,140	1,110	1,130	1,140	1,110	1,140	1,140	1,110	1,130	1,140	1,110	1,140
Central water flow	m³/h	-	-	-	-	-	-	730	740	760	730	740	770
Seawater flow	m³/h	860	880	900	860	880	920	-	-	-	-	-	-
<b>Jacket water cooler</b>													
Heat diss. app.	kW	10,110	10,110	10,110	10,050	10,050	10,050	10,130	10,130	10,130	10,070	10,070	10,070
Jacket water flow	m³/h	530	530	530	520	520	520	530	530	530	530	530	530
Central water flow	m³/h	-	-	-	-	-	-	730	740	760	730	740	770
Seawater flow	m³/h	860	880	900	860	880	920	-	-	-	-	-	-
<b>Central cooler</b>													
Heat diss. app. *	kW	-	-	-	-	-	-	43,210	43,350	43,470	44,340	44,480	44,720
Central water flow	m³/h	-	-	-	-	-	-	1,700	1,710	1,730	1,750	1,760	1,790
Seawater flow	m³/h	-	-	-	-	-	-	2,110	2,120	2,120	2,170	2,170	2,190
<b>Starting air system, 30.0 bar g, 12 starts. Fixed pitch propeller - reversible engine</b>													
Receiver volume	m³	2 x 19.0	2 x 19.0	2 x 19.0	2 x 19.0	2 x 19.0	2 x 19.0	2 x 19.0	2 x 19.0	2 x 19.0	2 x 19.0	2 x 19.0	2 x 19.0
Compressor cap.	m³	1,140	1,140	1,140	1,140	1,140	1,140	1,140	1,140	1,140	1,140	1,140	1,140
<b>Starting air system, 30.0 bar g, 6 starts. Controllable pitch propeller - non-reversible engine</b>													
Receiver volume	m³	2 x 10.0	2 x 10.0	2 x 10.0	2 x 10.0	2 x 10.0	2 x 10.0	2 x 10.0	2 x 10.0	2 x 10.0	2 x 10.0	2 x 10.0	2 x 10.0
Compressor cap.	m³	600	600	600	600	600	600	600	600	600	600	600	600
<b>Other values</b>													
Fuel oil heater	kW	591	591	591	587	587	587	592	592	592	589	589	589
Exh. gas temp. **	°C	260	260	260	240	240	240	260	260	260	240	240	240
Exh. gas amount **	kg/h	564,280	564,280	564,280	601,990	601,990	601,990	564,280	564,280	564,280	601,990	601,990	601,990
Air consumption **	kg/s	139.8	139.8	139.8	149.4	149.4	149.4	141.1	141.1	141.1	150.8	150.8	150.8

\* For main engine arrangements with built-on power take-off (PTO) of a MAN Diesel & Turbo recommended type and/or torsional vibration damper the engine's capacities must be increased by those stated for the actual system

\*\* ISO based

For List of Capacities for derated engines and performance data at part load please visit <http://www.mandieselturbo.com/ceas/LOC>

Table 6.03.01k: Capacities for seawater and central systems as well as conventional and high efficiency turbochargers stated at NMCR



List of Capacities for 12G95ME-C9.5-TII at NMCR

	Seawater cooling						Central cooling						
	Conventional TC			High eff. TC			Conventional TC			High eff. TC			
	3 x TCA88-21	3 x A285-L	3 x MET90-MB	3 x TCA88-26	3 x A285-L	3 x MET90-MB	3 x TCA88-21	3 x A285-L	3 x MET90-MB	3 x TCA88-26	3 x A285-L	3 x MET90-MB	
<b>Pumps</b>													
Fuel oil circulation	m³/h	36.2	36.2	36.2	36.0	36.0	36.0	36.3	36.3	36.3	36.1	36.1	36.1
Fuel oil supply	m³/h	21.9	21.9	21.9	21.8	21.8	21.8	22.0	22.0	22.0	21.8	21.8	21.8
Jacket cooling	m³/h	580	580	580	570	570	570	580	580	580	570	570	570
Seawater cooling *	m³/h	2390	2410	2440	2460	2480	2510	2300	2310	2320	2360	2370	2380
Main lubrication oil *	m³/h	1320	1300	1320	1320	1300	1320	1320	1300	1320	1320	1300	1320
Central cooling *	m³/h	-	-	-	-	-	-	1,850	1,870	1,890	1,900	1,920	1,940
<b>Scavenge air cooler(s)</b>													
Heat diss. app.	kW	29,720	29,720	29,720	31,040	31,040	31,040	29,650	29,650	29,650	30,950	30,950	30,950
Central water flow	m³/h	-	-	-	-	-	-	1,060	1,060	1,060	1,110	1,110	1,110
Seawater flow	m³/h	1,450	1,450	1,450	1,520	1,520	1,520	-	-	-	-	-	-
<b>Lubricating oil cooler</b>													
Heat diss. app. *	kW	6,390	6,530	6,770	6,390	6,530	6,770	6,410	6,550	6,790	6,410	6,550	6,790
Lube oil flow *	m³/h	1,320	1,300	1,320	1,320	1,300	1,320	1,320	1,300	1,320	1,320	1,300	1,320
Central water flow	m³/h	-	-	-	-	-	-	790	810	830	790	810	830
Seawater flow	m³/h	940	960	990	940	960	990	-	-	-	-	-	-
<b>Jacket water cooler</b>													
Heat diss. app.	kW	11,030	11,030	11,030	10,960	10,960	10,960	11,060	11,060	11,060	10,990	10,990	10,990
Jacket water flow	m³/h	580	580	580	570	570	570	580	580	580	570	570	570
Central water flow	m³/h	-	-	-	-	-	-	790	810	830	790	810	830
Seawater flow	m³/h	940	960	990	940	960	990	-	-	-	-	-	-
<b>Central cooler</b>													
Heat diss. app. *	kW	-	-	-	-	-	-	47,120	47,260	47,500	48,350	48,490	48,730
Central water flow	m³/h	-	-	-	-	-	-	1,850	1,870	1,890	1,900	1,920	1,940
Seawater flow	m³/h	-	-	-	-	-	-	2,300	2,310	2,320	2,360	2,370	2,380
<b>Starting air system, 30.0 bar g, 12 starts. Fixed pitch propeller - reversible engine</b>													
Receiver volume	m³	2 x 19.5	2 x 19.5	2 x 19.5	2 x 19.5	2 x 19.5	2 x 19.5	2 x 19.5	2 x 19.5	2 x 19.5	2 x 19.5	2 x 19.5	2 x 19.5
Compressor cap.	m³	1,170	1,170	1,170	1,170	1,170	1,170	1,170	1,170	1,170	1,170	1,170	1,170
<b>Starting air system, 30.0 bar g, 6 starts. Controllable pitch propeller - non-reversible engine</b>													
Receiver volume	m³	2 x 10.5	2 x 10.5	2 x 10.5	2 x 10.5	2 x 10.5	2 x 10.5	2 x 10.5	2 x 10.5	2 x 10.5	2 x 10.5	2 x 10.5	2 x 10.5
Compressor cap.	m³	630	630	630	630	630	630	630	630	630	630	630	630
<b>Other values</b>													
Fuel oil heater	kW	644	644	644	641	641	641	646	646	646	642	642	642
Exh. gas temp. **	°C	260	260	260	240	240	240	260	260	260	240	240	240
Exh. gas amount **	kg/h	615,580	615,580	615,580	656,720	656,720	656,720	615,580	615,580	615,580	656,720	656,720	656,720
Air consumption **	kg/s	152.5	152.5	152.5	163.0	163.0	163.0	153.9	153.9	153.9	164.5	164.5	164.5

\* For main engine arrangements with built-on power take-off (PTO) of a MAN Diesel & Turbo recommended type and/or torsional vibration damper the engine's capacities must be increased by those stated for the actual system

\*\* ISO based

For List of Capacities for derated engines and performance data at part load please visit <http://www.mandieselturbo.com/ceas/LOC>

Table 6.03.011: Capacities for seawater and central systems as well as conventional and high efficiency turbochargers stated at NMCR



### Auxiliary Machinery Capacities

The dimensioning of heat exchangers (coolers) and pumps for derated engines can be calculated on the basis of the heat dissipation values found by using the following description and diagrams. Those for the nominal MCR ( $L_1$ ), may also be used if wanted.

The nomenclature of the basic engine ratings and coolers, etc. used in this section is shown in Fig. 6.01.01 and 6.01.02.

### Cooler heat dissipations

For the specified MCR ( $M$ ) the following three diagrams in Figs. 6.04.01, 6.04.02 and 6.04.03 show reduction factors for the corresponding heat dissipations for the coolers, relative to the values stated in the 'List of Capacities' valid for nominal MCR ( $L_1$ ).

The percentage power ( $P_{M\%}$ ) and speed ( $n_{M\%}$ ) of  $L_1$  ie:  $P_{M\%} = P_M/P_{L1} \times 100\%$   
 $n_{M\%} = n_M/n_{L1} \times 100\%$   
for specified MCR ( $M$ ) of the derated engine is used as input in the above-mentioned diagrams, giving the % heat dissipation figures relative to those in the 'List of Capacities'.

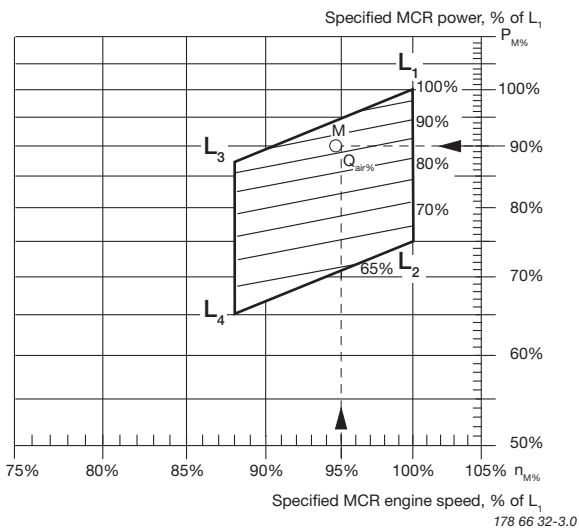

$$Q_{air\%} = 100 \times (P_M/P_{L1})^{1.68} \times (n_M/n_{L1})^{-0.83} = 1$$

Fig. 6.04.01: Scavenge air cooler, heat dissipation  $Q_{air\%}$  in point M, in % of the  $L_1$  value  $Q_{air, L1}$

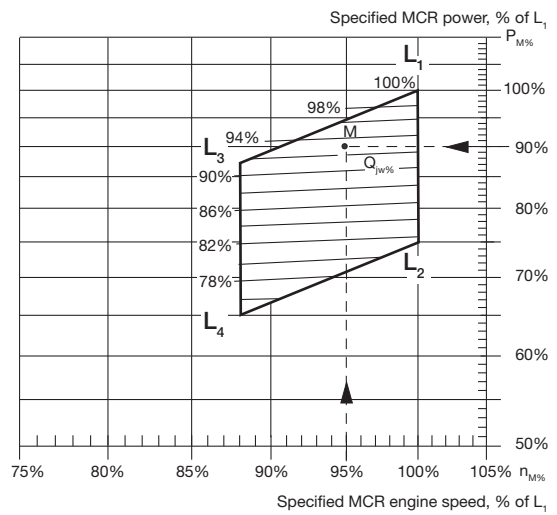

$$Q_{jw\%} = e^{(-0.0811 \times \ln(n_{M\%}) + 0.8072 \times \ln(P_{M\%}) + 1.2614)} \quad 178\ 66\ 33-5.0$$

Fig. 6.04.02: Jacket water cooler, heat dissipation  $Q_{jw\%}$  in point M, in % of the  $L_1$  value  $Q_{jw, L1}$

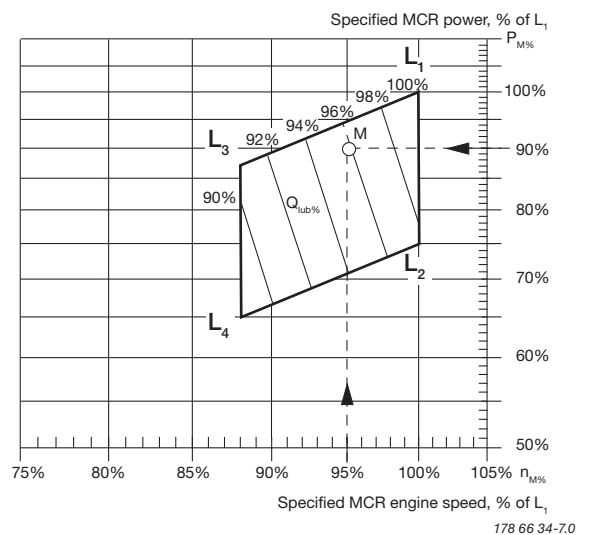

$$Q_{lub\%} = 67.3009 \times \ln(n_{M\%}) + 7.6304 \times \ln(P_{M\%}) - 245.0714 \quad 178\ 66\ 34-7.0$$

Fig. 6.04.03: Lubricating oil cooler, heat dissipation  $Q_{lub\%}$  in point M, in % of the  $L_1$  value  $Q_{lub, L1}$



The derated cooler capacities may then be found by means of following equations:

$$Q_{air, M} = Q_{air, L1} \times (Q_{air\%} / 100)$$

$$Q_{jw, M} = Q_{jw, L1} \times (Q_{jw\%} / 100)$$

$$Q_{lub, M} = Q_{lub, L1} \times (Q_{lub\%} / 100)$$

and for a central cooling water system the central cooler heat dissipation is:

$$Q_{cent, M} = Q_{air, M} + Q_{jw, M} + Q_{lub, M}$$

### Pump capacities

The pump capacities given in the 'List of Capacities' refer to engines rated at nominal MCR (L<sub>1</sub>). For lower rated engines, a marginal saving in the pump capacities is obtainable.

To ensure proper lubrication, the lubricating oil pump must remain unchanged.

In order to ensure reliable starting, the starting air compressors and the starting air receivers must also remain unchanged.

The jacket cooling water pump capacity is relatively low. Practically no saving is possible, and it is therefore unchanged.

### Seawater cooling system

The derated seawater pump capacity is equal to the sum of the below found derated seawater flow capacities through the scavenge air and lube oil coolers, as these are connected in parallel.

The seawater flow capacity for each of the scavenge air, lube oil and jacket water coolers can be reduced proportionally to the reduced heat dissipations found in Figs. 6.04.01, 6.04.02 and 6.04.03, respectively i.e. as follows:

$$V_{sw, air, M} = V_{sw, air, L1} \times (Q_{air\%} / 100)$$

$$V_{sw, lub, M} = V_{sw, lub, L1} \times (Q_{lub\%} / 100)$$

$$V_{sw, jw, M} = V_{sw, lub, M}$$

However, regarding the scavenge air cooler(s), the engine maker has to approve this reduction in order to avoid too low a water velocity in the scavenge air cooler pipes.

As the jacket water cooler is connected in series with the lube oil cooler, the seawater flow capacity for the latter is used also for the jacket water cooler.

### Central cooling water system

If a central cooler is used, the above still applies, but the central cooling water capacities are used instead of the above seawater capacities. The seawater flow capacity for the central cooler can be reduced in proportion to the reduction of the total cooler heat dissipation, i.e. as follows:

$$V_{cw, air, M} = V_{cw, air, L1} \times (Q_{air\%} / 100)$$

$$V_{cw, lub, M} = V_{cw, lub, L1} \times (Q_{lub\%} / 100)$$

$$V_{cw, jw, M} = V_{cw, lub, M}$$

$$V_{cw, cent, M} = V_{cw, air, M} + V_{cw, lub, M}$$

$$V_{sw, cent, M} = V_{sw, cent, L1} \times Q_{cent, M} / Q_{cent, L1}$$

### Pump pressures

Irrespective of the capacities selected as per the above guidelines, the below-mentioned pump heads at the mentioned maximum working temperatures for each system must be kept:

	Pump head bar	Max. working temp. °C
Fuel oil supply pump	4	100
Fuel oil circulating pump	6	150
Lubricating oil pump	4.8	70
Seawater pump	2.5	50
Central cooling water pump	2.5	80
Jacket water pump	3.0	100

### Flow velocities

For external pipe connections, we prescribe the following maximum velocities:

- Marine diesel oil ..... 1.0 m/s
- Heavy fuel oil ..... 0.6 m/s
- Lubricating oil ..... 1.8 m/s
- Cooling water ..... 3.0 m/s



## Calculation of List of Capacities for Derated Engine

### Example 1:

**Pump and cooler capacities for a derated 6G95ME-C9.5-TII with 2 high efficiency MAN TCA77-26 turbochargers, high load, fixed pitch propeller and central cooling water system.**

Nominal MCR, (L)  $P_{L1}$ : 41.220 kW (100.0%) and 80,0 r/min (100.0%)

Specified MCR, (M)  $P_M$ : 37.098 kW (90,0%) and 76,0 r/min (95.0%)

The method of calculating the reduced capacities for point M ( $n_{M\%} = 95.0\%$  and  $P_{M\%} = 90,0\%$ ) is shown below.

The values valid for the nominal rated engine are found in the 'List of Capacities', Figs. 6.03.01 and 6.03.02, and are listed together with the result in the figure on the next page.

#### Heat dissipation of scavenge air cooler

Fig. 6.04.01 which approximately indicates a  $Q_{air\%} = 87,4\%$  heat dissipation, i.e.:

$$Q_{air,M} = Q_{air,L1} \times Q_{air\%} / 100$$

$$Q_{air,M} = 15.480 \times 0,874 = 13.530 \text{ kW}$$

#### Heat dissipation of jacket water cooler

Fig. 6.04.02 indicates a  $Q_{jw\%} = 92,2\%$  heat dissipation; i.e.:

$$Q_{jw,M} = Q_{jw,L1} \times Q_{jw\%} / 100$$

$$Q_{jw,M} = 5.490 \times 0,922 = 5.062 \text{ kW}$$

#### Heat dissipation of lube oil cooler

Fig. 6.04.03 indicates a  $Q_{lub\%} = 95,7\%$  heat dissipation; i.e.:

$$Q_{lub,M} = Q_{lub,L1} \times Q_{lub\%} / 100$$

$$Q_{lub,M} = 3.260 \times 0,957 = 3.120 \text{ kW}$$

#### Heat dissipation of central water cooler

$$Q_{cent,M} = Q_{air,M} + Q_{jw,M} + Q_{lub,M}$$

$$Q_{cent,M} = 13.530 + 5.062 + 3.120 = 21.712 \text{ kW}$$

#### Total cooling water flow through scavenge air coolers

$$V_{cw,air,M} = V_{cw,air,L1} \times Q_{air\%} / 100$$

$$V_{cw,air,M} = 560 \times 0,874 = 489 \text{ m}^3/\text{h}$$

#### Cooling water flow through lubricating oil cooler

$$V_{cw,lub,M} = V_{cw,lub,L1} \times Q_{lub\%} / 100$$

$$V_{cw,lub,M} = 400 \times 0,957 = 383 \text{ m}^3/\text{h}$$

#### Cooling water flow through central cooler (Central cooling water pump)

$$V_{cw,cent,M} = V_{cw,air,M} + V_{cw,lub,M}$$

$$V_{cw,cent,M} = 489 + 383 = 872 \text{ m}^3/\text{h}$$

#### Cooling water flow through jacket water cooler (as for lube oil cooler)

$$V_{cw,jw,M} = V_{cw,lub,M}$$

$$V_{cw,jw,M} = 383 \text{ m}^3/\text{h}$$

#### Seawater pump for central cooler

As the seawater pump capacity and the central cooler heat dissipation for the nominal rated engine found in the 'List of Capacities' are 1.180 m<sup>3</sup>/h and 24.230 kW the derated seawater pump flow equals:

#### Seawater pump:

$$V_{sw,cent,M} = V_{sw,cent,L1} \times Q_{cent,M} / Q_{cent,L1}$$

$$= 1.180 \times 21.712 / 24.230 = 1.057 \text{ m}^3/\text{h}$$





		Nominal rated engine (L <sub>1</sub> ) high efficiency 2 x MAN TCA88-21	Specified MCR (M) high efficiency 2 x MAN TCA77-26
Shaft power at MCR	kW	41.220	37.098
Engine speed at MCR	r/min	80,0	76,0
<b>Pumps:</b>			
Fuel oil circulating	m <sup>3</sup> /h	18,1	16,7
Fuel oil supply	m <sup>3</sup> /h	10,9	9,7
Jacket cooling water	m <sup>3</sup> /h	290	260
Central cooling water	m <sup>3</sup> /h	960	872
Seawater	m <sup>3</sup> /h	1.180	1.057
Lubricating oil	m <sup>3</sup> /h	700	680
<b>Coolers:</b>			
<b>Scavenge air cooler</b>			
Heat dissipation	kW	15.480	13.530
Central cooling water flow	m <sup>3</sup> /h	560	489
<b>Lub. oil cooler</b>			
Heat dissipation	kW	3.260	3.120
Lubricating oil flow	m <sup>3</sup> /h	700	680
Central cooling water flow	m <sup>3</sup> /h	400	383
<b>Jacket water cooler</b>			
Heat dissipation	kW	5.490	5.062
Jacket cooling water flow	m <sup>3</sup> /h	290	260
Central cooling water flow	m <sup>3</sup> /h	400	383
<b>Central cooler</b>			
Heat dissipation	kW	24.230	21.712
Central cooling water flow	m <sup>3</sup> /h	960	872
Seawater flow	m <sup>3</sup> /h	1.180	1.057
<b>Fuel oil heater:</b>			
	kW	318	285
<b>Gases at ISO ambient conditions*</b>			
Exhaust gas amount	kg/h	328.400	294.800
Exhaust gas temperature	°C	240	236
Air consumption	kg/s	89,3	80,4
<b>Starting air system: 30 bar (gauge)</b>			
<b>Reversible engine</b>			
Receiver volume (12 starts)	m <sup>3</sup>	2 x 18,0	2 x 18,0
Compressor capacity, total	m <sup>3</sup> /h	1.080	1.080
<b>Non-reversible engine</b>			
Receiver volume (6 starts)	m <sup>3</sup>	2 x 9,5	2 x 9,5
Compressor capacity, total	m <sup>3</sup> /h	570	570
Exhaust gas tolerances: temperature $\pm 5$ °C and amount $\pm 15\%$			

The air consumption and exhaust gas figures are expected and refer to 100% specified MCR, ISO ambient reference conditions and the exhaust gas back pressure 300 mm WC

The exhaust gas temperatures refer to after turbocharger

\* Calculated in example 3, in this chapter





## Freshwater Generator

If a freshwater generator is installed and is utilising the heat in the jacket water cooling system, it should be noted that the actual available heat in the jacket cooling water system is **lower** than indicated by the heat dissipation figures valid for nominal MCR ( $L_1$ ) given in the List of Capacities. This is because the latter figures are used for dimensioning the jacket water cooler and hence incorporate a safety margin which can be needed when the engine is operating under conditions such as, e.g. overload. Normally, this margin is 10% at nominal MCR.

### Calculation Method

For a derated diesel engine, i.e. an engine having a specified MCR ( $M$ ) different from  $L_1$ , the relative jacket water heat dissipation for point  $M$  may be found, as previously described, by means of Fig. 6.04.02.

Part load correction factor for jacket cooling water heat dissipation

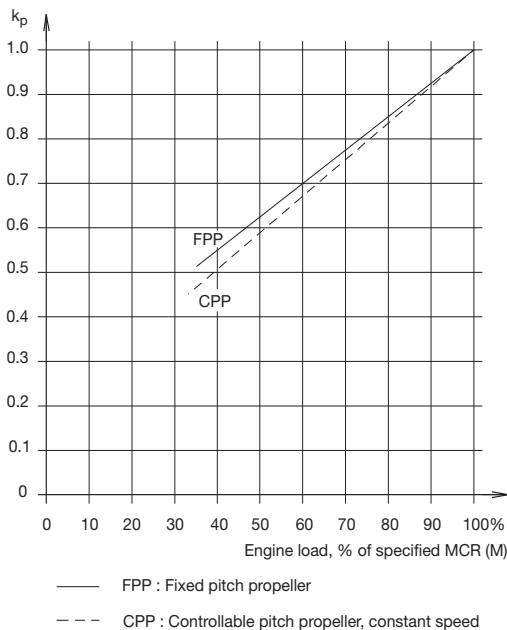

178 06 64-3.3

$$\text{FPP : } k_p = 0.742 \times \frac{P_s}{P_M} + 0.258$$

$$\text{CPP : } k_p = 0.822 \times \frac{P_s}{P_M} + 0.178$$

Fig. 6.04.04: Correction factor 'kp' for jacket cooling water heat dissipation at part load, relative to heat dissipation at specified MCR power

At part load operation, the actual jacket water heat dissipation will be reduced according to the curves for fixed pitch propeller (FPP) or for constant speed, controllable pitch propeller (CPP), respectively, in Fig. 6.04.04.

With reference to the above, the heat actually available for a derated diesel engine may then be found as follows:

1. Engine power equal to specified power  $M$ .

For specified MCR ( $M$ ) the diagram Fig. 6.04.02 is to be used, i.e. giving the percentage correction factor 'Q<sub>jw%</sub>' and hence for specified MCR power  $P_M$ :

$$Q_{jw,M} = Q_{jw,L1} \times \frac{Q_{jw\%}}{100} \times 0.9 \quad [1]$$

2. Engine power lower than specified MCR power.

For powers lower than the specified MCR power, the value  $Q_{jw,M}$  found for point  $M$  by means of the above equation [1] is to be multiplied by the correction factor  $k_p$  found in Fig. 6.04.04 and hence

$$Q_{jw} = Q_{jw,M} \times k_p \text{ -15%/0\%} \quad [2]$$

where

$Q_{jw}$  = jacket water heat dissipation

$Q_{jw,L1}$  = jacket water heat dissipation at nominal MCR ( $L_1$ )

$Q_{jw\%}$  = percentage correction factor from Fig. 6.04.02

$Q_{jw,M}$  = jacket water heat dissipation at specified MCR power ( $M$ ), found by means of equation [1]

$k_p$  = part load correction factor from Fig. 6.04.04

0.9 = factor for safety margin of cooler, tropical ambient conditions

The heat dissipation is assumed to be more or less independent of the ambient temperature conditions, yet the safety margin/ambient condition factor of about 0.88 instead of 0.90 will be more accurate for ambient conditions corresponding to ISO temperatures or lower. The heat dissipation tolerance from -15% to 0% stated above is based on experience.



## Calculation of Freshwater Production for Derated Engine

### Example 2:

**Freshwater production from a derated 6G95ME-C9.5-TII with 2 high efficiency MAN TCA77-26 turbochargers, high load and fixed pitch propeller.**

Based on the engine ratings below, this example will show how to calculate the expected available jacket cooling water heat removed from the diesel engine, together with the corresponding freshwater production from a freshwater generator.

The calculation is made for the service rating (S) of the diesel engine being 80% of the specified MCR.

Nominal MCR, (L)  $P_{L1}$ : 41.220 kW (100.0%) and 80,0 r/min (100.0%)

Specified MCR, (M)  $P_M$ : 37.098 kW (90,0%) and 76,0 r/min (95.0%)

Service rating, (S)  $P_S$ : 29.678 kW and 70,6 r/min,  $P_S = 80,0\%$  of  $P_M$

### Reference conditions

Air temperature  $T_{air}$  ..... 20° C  
 Scavenge air coolant temperature  $T_{CW}$  ..... 18° C  
 Barometric pressure  $p_{bar}$  ..... 1.013 mbar  
 Exhaust gas back-pressure at specified MCR  $\Delta p_M$  ..... 300 mm WC

The expected available jacket cooling water heat at service rating is found as follows:

$$Q_{jw,L1} = 5.490 \text{ kW from List of Capacities}$$

$$Q_{jw\%} = 92,2\% \text{ using } 90,0\% \text{ power and } 95.0\% \text{ speed for M in Fig. 6.04.02}$$

For the service point the corresponding expected obtainable freshwater production from a freshwater generator of the single effect vacuum evaporator type is then found from equation [3]:

By means of equation [1], and using factor 0,885 for actual ambient condition the heat dissipation in the SMCR point (M) is found:

$$M_{fw} = 0,03 \times Q_{jw} = 0,03 \times 3.817 = 134,4 \text{ t/24h}$$

-15%/0%

$$Q_{jw,M} = Q_{jw,L1} \times \frac{Q_{jw\%}}{100} \times 0,885$$

$$= 5.490 \times \frac{92,2}{100} \times 0,885 = 4.480 \text{ kW}$$

By means of equation [2], the heat dissipation in the service point (S) i.e. for 80.0% of specified MCR power, is found:

$$k_p = 0,852 \text{ using } 80.0\% \text{ in Fig. 6.04.04}$$

$$Q_{jw} = Q_{jw,M} \times k_p = 4.480 \times 0,852 = 3.817 \text{ kW}$$

-15%/0%



## Exhaust Gas Amount and Temperature

### Influencing factors

The exhaust gas data to be expected in practice depends, primarily, on the following three factors:

a) The specified MCR point of the engine (point M):

$P_M$  : power in kW at specified MCR point  
 $n_M$  : speed in r/min at specified MCR point

b) The ambient conditions, and exhaust gas back-pressure:

$T_{air}$  : actual ambient air temperature, in °C  
 $p_{bar}$  : actual barometric pressure, in mbar

$T_{CW}$  : actual scavenge air coolant temperature, in °C

$\Delta p_M$  : exhaust gas back-pressure in mm WC at specified MCR

c) The continuous service rating of the engine (point S), valid for fixed pitch propeller or controllable pitch propeller (constant engine speed):

$P_S$  : continuous service rating of engine, in kW

### Calculation Method

To enable the project engineer to estimate the actual exhaust gas data at an arbitrary service rating, the following method of calculation may be used.

The partial calculations based on the above influencing factors have been summarised in equations [4] and [5].

$M_{exh}$  : exhaust gas amount in kg/h, to be found  
 $T_{exh}$  : exhaust gas temperature in °C, to be found

$$M_{exh} = M_{L1} \times \frac{P_M}{P_{L1}} \times \left\{ 1 + \frac{\Delta m_{M\%}}{100} \right\} \times \left\{ 1 + \frac{\Delta M_{amb\%}}{100} \right\} \times \left\{ 1 + \frac{\Delta m_{s\%}}{100} \right\} \times \frac{P_{S\%}}{100} \quad \text{kg/h} \quad \pm 5\% \quad [4]$$

$$T_{exh} = T_{L1} + \Delta T_M + \Delta T_{amb} + \Delta T_S \quad \text{°C} \quad \pm 15 \quad [5]$$

where, according to 'List of capacities', i.e. referring to ISO ambient conditions and 300 mm WC back-pressure and specified in  $L_1$ :

$M_{L1}$ : exhaust gas amount in kg/h at nominal MCR ( $L_1$ )  
 $T_{L1}$ : exhaust gas temperature after turbocharger in °C at nominal MCR ( $L_1$ )

Fig. 6.04.06: Summarising equations for exhaust gas amounts and temperatures

The partial calculations based on the influencing factors are described in the following:

a) *Correction for choice of specified MCR point*

When choosing a specified MCR point 'M' other than the nominal MCR point ' $L_1$ ', the resulting

changes in specific exhaust gas amount and temperature are found by using as input in diagrams the corresponding percentage values (of  $L_1$ ) for specified MCR power  $P_{M\%}$  and speed  $n_{M\%}$ :

$$P_{M\%} = \frac{P_M}{P_{L1}} \times 100\%$$

$$n_{M\%} = \frac{n_M}{n_{L1}} \times 100\%$$

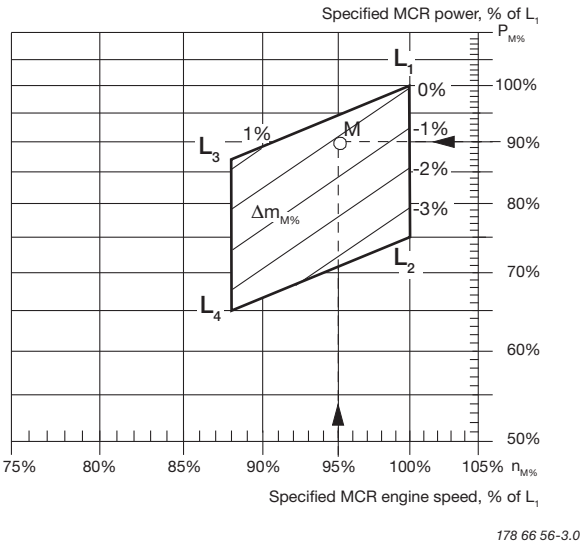

$$\Delta m_{M\%} = 14 \times \ln (P_M/P_{L1}) - 24 \times \ln (n_M/n_{L1})$$

Fig. 6.04.07: Change of specific exhaust gas amount,  $\Delta m_{M\%}$  in % of  $L_1$  value

$\Delta m_{M\%}$ : change of specific exhaust gas amount, in % of specific gas amount at nominal MCR ( $L_1$ ), see Fig. 6.04.07.

$\Delta T_M$ : change in exhaust gas temperature after turbocharger relative to the  $L_1$  value, in °C, see Fig. 6.04.08.

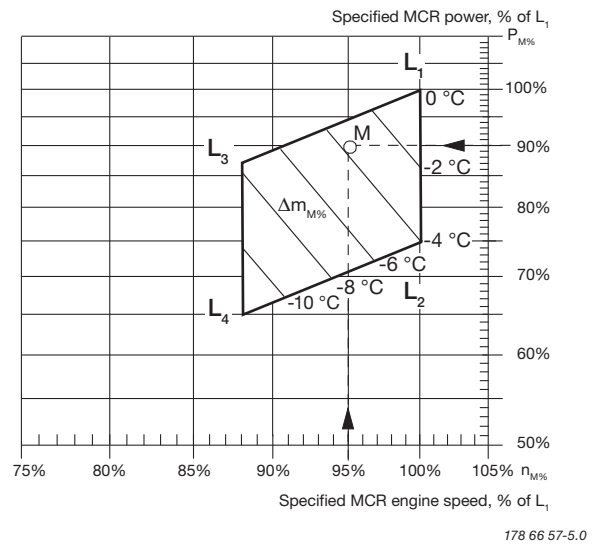

$$\Delta T_M = 15 \times \ln (P_M/P_{L1}) + 45 \times \ln (n_M/n_{L1})$$

Fig. 6.04.08: Change of exhaust gas temperature,  $\Delta T_M$  in point M, in °C after turbocharger relative to  $L_1$  value

b) Correction for actual ambient conditions and back-pressure

For ambient conditions other than ISO 3046-1:2002 (E) and ISO 15550:2002 (E), and back-pressure other than 300 mm WC at specified MCR point (M), the correction factors stated in the table in Fig. 6.04.09 may be used as a guide, and the corresponding relative change in the exhaust gas data may be found from equations [7] and [8], shown in Fig. 6.04.10.

Parameter	Change	Change of exhaust gas temperature	Change of exhaust gas amount
Blower inlet temperature	+ 10° C	+ 16.0° C	- 4.1 %
Blower inlet pressure (barometric pressure)	+ 10 mbar	- 0.1° C	+ 0.3 %
Charge air coolant temperature (seawater temperature)	+ 10° C	+ 1.0° C	+ 1.9 %
Exhaust gas back pressure at the specified MCR point	+ 100 mm WC	+ 5.0° C	-1.1 %

Fig. 6.04.09: Correction of exhaust gas data for ambient conditions and exhaust gas back pressure



$$\Delta M_{amb\%} = -0.41 \times (T_{air} - 25) + 0.03 \times (p_{bar} - 1000) + 0.19 \times (T_{CW} - 25) - 0.011 \times (\Delta p_M - 300) \% \quad [7]$$

$$\Delta T_{amb} = 1.6 \times (T_{air} - 25) - 0.01 \times (p_{bar} - 1000) + 0.1 \times (T_{CW} - 25) + 0.05 \times (\Delta p_M - 300) \text{ } ^\circ\text{C} \quad [8]$$

where the following nomenclature is used:

$\Delta M_{amb\%}$  : change in exhaust gas amount, in % of amount at ISO conditions

$\Delta T_{amb}$  : change in exhaust gas temperature, in  $^\circ\text{C}$  compared with temperatures at ISO conditions

Fig. 6.04.10: Exhaust gas correction formula for ambient conditions and exhaust gas back pressure

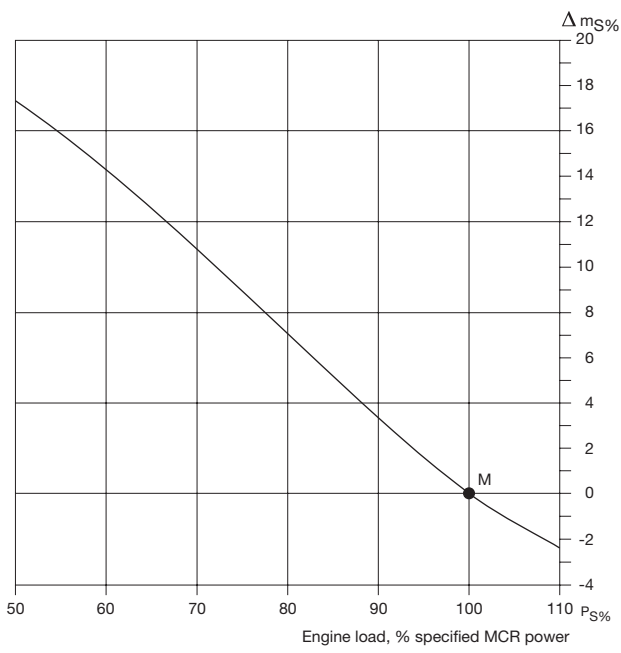

178 24 62-3.0

$$P_{S\%} = (P_S/P_M) \times 100\%$$

$$\Delta m_{S\%} = 37 \times (P_S/P_M)^3 - 87 \times (P_S/P_M)^2 + 31 \times (P_S/P_M) + 19$$

Fig. 6.04.11: Change of specific exhaust gas amount,  $\Delta m_{S\%}$  in % at part load, and valid for FPP and CPP

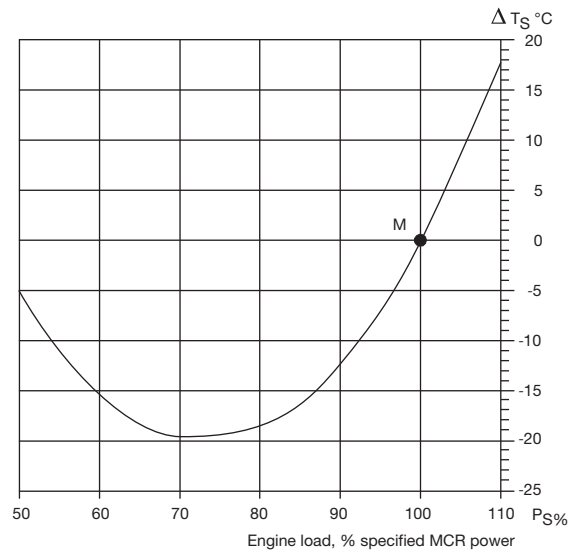

178 24 63-5.0

$$P_{S\%} = (P_S/P_M) \times 100\%$$

$$\Delta T_S = 280 \times (P_S/P_M)^2 - 410 \times (P_S/P_M) + 130$$

Fig. 6.04.12: Change of exhaust gas temperature,  $\Delta T_S$  in  $^\circ\text{C}$  at part load, and valid for FPP and CPP

c) Correction for engine load

Figs. 6.04.11 and 6.04.12 may be used, as guidance, to determine the relative changes in the specific exhaust gas data when running at part load, compared to the values in the specified MCR point, i.e. using as input  $P_{S\%} = (P_S/P_M) \times 100\%$ :

$\Delta m_{S\%}$  : change in specific exhaust gas amount, in % of specific amount at specified MCR point, see Fig. 6.04.11.

$\Delta T_S$  : change in exhaust gas temperature, in  $^\circ\text{C}$ , see Fig. 6.04.12.



### Calculation of Exhaust Data for Derated Engine

**Example 3:**

**Expected exhaust gas data for a derated 6G95ME-C9.5-TII with 2 high efficiency MAN TCA77-26 turbochargers, high load and fixed pitch propeller.**

Based on the engine ratings below, and by means of an example, this chapter will show how to calculate the expected exhaust gas amount and temperature at service rating, and for a given ambient reference condition different from ISO.

The calculation is made for the service rating (S) of the diesel engine being 80% of the specified MCR.

Nominal MCR, (L)  $P_{L1}$ : 41.220 kW (100.0%) and 80,0 r/min (100.0%)

Specified MCR, (M)  $P_M$ : 37.098 kW (90,0%) and 76,0 r/min (95.0%)

Service rating, (S)  $P_S$ : 29.678 kW and 70,6 r/min,  $P_S = 80,0\%$  of  $P_M$

**Reference conditions**

Air temperature $T_{air}$ .....	20° C
Scavenge air coolant temperature $T_{CW}$ .....	18° C
Barometric pressure $p_{bar}$ .....	1.013 mbar
Exhaust gas back-pressure at specified MCR $\Delta p_M$ .....	300 mm WC

a) Correction for choice of specified MCR point M:

$$\Delta M_{amb\%} = + 1.11\%$$

$$P_{M\%} = \frac{37.098}{41.220} \times 100 = 90,0\%$$

$$\Delta T_{amb} = 1.6 \times (20 - 25) - 0.01 \times (1,013 - 1,000) + 0.1 \times (18 - 25) + 0.05 \times (300 - 300) \text{ °C}$$

$$\eta_{M\%} = \frac{76,0}{80,0} \times 100 = 95.0\%$$

$$\Delta T_{amb} = - 8.8 \text{ °C}$$

By means of Figs. 6.04.07 and 6.04.08:

c) Correction for the engine load:

$$\Delta m_{M\%} = -0,24\%$$

$$\Delta T_M = -3,9 \text{ °C}$$

Service rating = 80% of specified MCR power  
By means of Figs. 6.04.11 and 6.04.12:

b) Correction for ambient conditions and back-pressure:

$$\Delta m_{S\%} = + 7.1\%$$

By means of equations [7] and [8]:

$$\Delta T_S = - 18.8 \text{ °C}$$

$$\Delta M_{amb\%} = - 0.41 \times (20 - 25) + 0.03 \times (1,013 - 1,000) + 0.19 \times (18 - 25) - 0.011 \times (300 - 300)\%$$



**Final calculation**

By means of equations [4] and [5], the final result is found taking the exhaust gas flow  $M_{L1}$  and temperature  $T_{L1}$  from the 'List of Capacities':

$$M_{L1} = 328.400 \text{ kg/h}$$

$$M_{\text{exh}} = 328.400 \times \frac{37.098}{41.220} \times (1 + \frac{-0.24}{100}) \times$$

$$(1 + \frac{1.11}{100}) \times (1 + \frac{7.1}{100}) \times \frac{80}{100} = 255.432 \text{ kg/h}$$

$$M_{\text{exh}} = 255.400 \text{ kg/h} \pm 15\%$$

**The exhaust gas temperature**

$$T_{L1} = 240 \text{ }^\circ\text{C}$$

$$T_{\text{exh}} = 240 - 3,9 - 8,8 - 18,8 = 208,5 \text{ }^\circ\text{C}$$

$$T_{\text{exh}} = 208,5 \text{ }^\circ\text{C} \pm 5 \text{ }^\circ\text{C}$$

**Exhaust gas data at specified MCR (ISO)**

At specified MCR (M), the running point may be in equations [4] and [5] considered as a service point where  $P_{s\%} = 100$ ,  $\Delta m_{s\%} = 0.0$  and  $\Delta T_s = 0.0$ .

For ISO ambient reference conditions where  $\Delta M_{\text{amb}\%} = 0.0$  and  $\Delta T_{\text{amb}} = 0.0$ , the corresponding calculations will be as follows:

$$M_{\text{exh,M}} = 328.400 \times \frac{37.098}{41.220} \times (1 + \frac{-0.24}{100}) \times (1 + \frac{0.0}{100}) \times (1 + \frac{0.0}{100}) \times \frac{100.0}{100} = 294.839 \text{ kg/h}$$

$$M_{\text{exh,M}} = 294.800 \text{ kg/h} \pm 15\%$$

$$T_{\text{exh,M}} = 240 - 3,9 + 0 + 0 = 236,1 \text{ }^\circ\text{C}$$

$$T_{\text{exh,M}} = 236,1 \text{ }^\circ\text{C} \pm 5 \text{ }^\circ\text{C}$$

The air consumption will be:

$$294.839 \times 0,982 \text{ kg/h} = 289.532 \text{ kg/h} \Leftrightarrow 289.532 / 3,600 \text{ kg/s} = 80,4 \text{ kg/s}$$



**MAN B&W**

---

---

**Fuel**

**7**

---

---

**MAN Diesel**





## Pressurised Fuel Oil System

The system is so arranged that both diesel oil and heavy fuel oil can be used, see Fig. 7.01.01.

From the service tank the fuel is led to an electrically driven supply pump by means of which a pressure of approximately 4 bar can be maintained in the low pressure part of the fuel circulating system, thus avoiding gasification of the fuel in the venting box in the temperature ranges applied.

The venting box is connected to the service tank via an automatic deaerating valve, which will release any gases present, but will retain liquids.

From the low pressure part of the fuel system the fuel oil is led to an electrically-driven circulating pump, which pumps the fuel oil through a heater and a full flow filter situated immediately before the inlet to the engine.

The fuel injection is performed by the electronically controlled pressure booster located on the Hydraulic Cylinder Unit (HCU), one per cylinder, which also contains the actuator for the electronic exhaust valve activation.

The Cylinder Control Units (CCU) of the Engine Control System (described in Section 16.01) calculate the timing of the fuel injection and the exhaust valve activation.

To ensure ample filling of the HCU, the capacity of the electrically-driven circulating pump is higher than the amount of fuel consumed by the diesel engine. Surplus fuel oil is recirculated from the engine through the venting box.

To ensure a constant fuel pressure to the fuel injection pumps during all engine loads, a spring loaded overflow valve is inserted in the fuel oil system on the engine.

The fuel oil pressure measured on the engine (at fuel pump level) should be 7-8 bar, equivalent to a circulating pump pressure of 10 bar.

### Fuel considerations

When the engine is stopped, the circulating pump will continue to circulate heated heavy fuel through the fuel oil system on the engine, thereby keeping the fuel pumps heated and the fuel valves deaerated. This automatic circulation of preheated fuel during engine standstill is the background for our recommendation: *constant operation on heavy fuel*.

In addition, if this recommendation was not followed, there would be a latent risk of diesel oil and heavy fuels of marginal quality forming incompatible blends during fuel change over or when operating in areas with restrictions on sulphur content in fuel oil due to exhaust gas emission control.

In special circumstances a change-over to diesel oil may become necessary – and this can be performed at any time, even when the engine is not running. Such a change-over may become necessary if, for instance, the vessel is expected to be inactive for a prolonged period with cold engine e.g. due to:

- docking
- stop for more than five days
- major repairs of the fuel system, etc.

The built-on overflow valves, if any, at the supply pumps are to be adjusted to 5 bar, whereas the external bypass valve is adjusted to 4 bar. The pipes between the tanks and the supply pumps shall have minimum 50% larger passage area than the pipe between the supply pump and the circulating pump.

If the fuel oil pipe 'X' at inlet to engine is made as a straight line immediately at the end of the engine, it will be necessary to mount an expansion joint. If the connection is made as indicated, with a bend immediately at the end of the engine, no expansion joint is required.



### Fuel Oil System

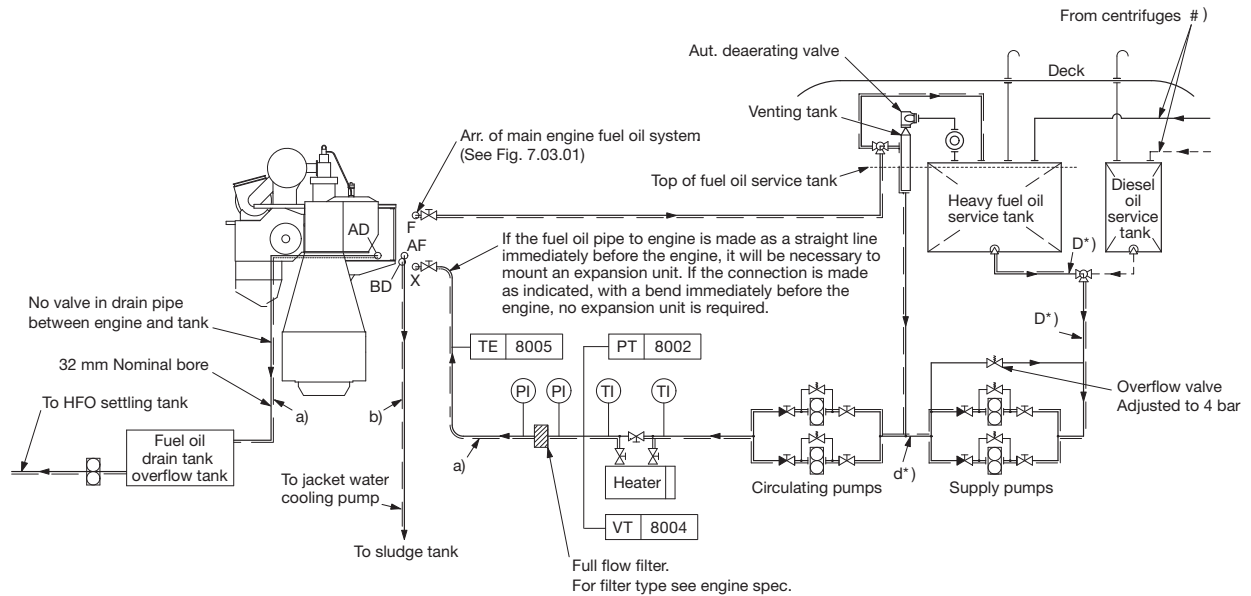

#) Approximately the following quantity of fuel oil should be treated in the centrifuges: 0.23 l/kwh as explained in Section 7.05. The capacity of the centrifuges to be according to manufacturer's recommendation.

\*) D to have min. 50% larger passage area than d.

178 52 19-7.4

- Diesel oil
- Heavy fuel oil
- ===== Heated pipe with insulation
- a) Tracing fuel oil lines: Max.150°C
- b) Tracing drain lines: By jacket cooling water

The letters refer to the list of 'Counterflanges'

Fig. 7.01.01: Fuel oil system



**Drain of clean fuel oil from HCU, pumps, pipes**

The HCU Fuel Oil Pressure Booster has a leakage drain of clean fuel oil from the umbrella sealing through 'AD' to the fuel oil drain tank.

The flow rate in litres is approximately as listed in Table 7.01.02.

Engine	Flow rate, litres/cyl. h. HFO 12 cSt
K98ME/ME-C,	0.65
S90ME-C, K90ME/ME-C	0.55
G/S/K80ME-C	0.50
G/S/L70ME-C, S70ME-C-GI, S65ME-C/-GI	0.40
G/S/L60ME-C, S60ME-C-GI, S60ME-B	0.30

Table 7.01.02: Approximate flow in HCU leakage drain.

This drained clean oil will, of course, influence the measured SFOC, but the oil is not wasted, and the quantity is well within the measuring accuracy of the flowmeters normally used.

The main purpose of the drain 'AD' is to collect fuel oil from the fuel pumps. As a safety measure for the crew during maintenance, an overhaul drain from the umbrella leads clean fuel oil from the umbrella directly to drain 'AF'. Also washing water from the cylinder cover and the baseplate is led to drain 'AF'.

The drain oil is led to a sludge tank and can be pumped to the Heavy Fuel Oil service tank or to the settling tank.

The 'AF' drain is provided with a box for giving alarm in case of leakage in a high pressure pipe.

The size of the sludge tank is determined on the basis of the draining intervals, the classification society rules, and on whether it may be vented directly to the engine room.

Drains 'AD', 'AF' and the drain for overhaul are shown in Fig. 7.03.01.

**Drain of contaminated fuel etc.**

Leakage oil, in shape of fuel and lubricating oil contaminated with water, dirt etc. and collected by the HCU Base Plate top plate, is drained off through the bedplate drains 'AE'.

Drain 'AE' is shown in Fig. 8.07.02.

**Heating of fuel drain pipes**

Owing to the relatively high viscosity of the heavy fuel oil, it is recommended that the drain pipes and the fuel oil drain tank are heated to min. 50 °C, but max. 100 °C.

The drain pipes between engine and tanks can be heated by the jacket water, as shown in Fig. 7.01.01 'Fuel oil system' as flange 'BD'.

**Fuel oil flow velocity and viscosity**

For external pipe connections, we prescribe the following maximum flow velocities:

- Marine diesel oil ..... 1.0 m/s
- Heavy fuel oil..... 0.6 m/s

The fuel viscosity is influenced by factors such as emulsification of water into the fuel for reducing the NO<sub>x</sub> emission. This is further described in Section 7.06.

An emulsification arrangement for the main engine is described in our publication:

*Exhaust Gas Emission Control Today and Tomorrow*

Further information about fuel oil specifications is available in our publication:

*Guidelines for Fuels and Lubes Purchasing*

The publications are available at [www.marine.man.eu](http://www.marine.man.eu) → 'Two-Stroke' → 'Technical Papers'.



## Fuel Oils

### Marine diesel oil:

Marine diesel oil ISO 8217, Class DMB  
British Standard 6843, Class DMB  
Similar oils may also be used

### Heavy fuel oil (HFO)

Most commercially available HFO with a viscosity below 700 cSt at 50 °C (7,000 sec. Redwood I at 100 °F) can be used.

For guidance on purchase, reference is made to ISO 8217:2012, British Standard 6843 and to CIMAC recommendations regarding requirements for heavy fuel for diesel engines, fourth edition 2003, in which the maximum acceptable grades are RMH 700 and RMK 700. The above-mentioned ISO and BS standards supersede BSMA 100 in which the limit was M9.

The data in the above HFO standards and specifications refer to fuel as delivered to the ship, i.e. before on-board cleaning.

In order to ensure effective and sufficient cleaning of the HFO, i.e. removal of water and solid contaminants, the fuel oil specific gravity at 15 °C (60 °F) should be below 0.991, unless modern types of centrifuges with adequate cleaning abilities are used.

Higher densities can be allowed if special treatment systems are installed.

Current analysis information is not sufficient for estimating the combustion properties of the oil. This means that service results depend on oil properties which cannot be known beforehand. This especially applies to the tendency of the oil to form deposits in combustion chambers, gas passages and turbines. It may, therefore, be necessary to rule out some oils that cause difficulties.

### Guiding heavy fuel oil specification

Based on our general service experience we have, as a supplement to the above mentioned standards, drawn up the guiding HFO specification shown below.

Heavy fuel oils limited by this specification have, to the extent of the commercial availability, been used with satisfactory results on MAN B&W two-stroke low speed diesel engines.

The data refers to the fuel as supplied i.e. before any on-board cleaning.

Guiding specification (maximum values)		
Density at 15 °C	kg/m <sup>3</sup>	≤ 1.010*
Kinematic viscosity	at 100 °C	cSt ≤ 55
	at 50 °C	cSt ≤ 700
Flash point	°C	≥ 60
Pour point	°C	≤ 30
Carbon residue	% (m/m)	≤ 20
Ash	% (m/m)	≤ 0.15
Total sediment potential	% (m/m)	≤ 0.10
Water	% (v/v)	≤ 0.5
Sulphur	% (m/m)	≤ 4.5
Vanadium	mg/kg	≤ 450
Aluminum + Silicon	mg/kg	≤ 60
Equal to ISO 8217:2010 - RMK 700 / CIMAC recommendation No. 21 - K700		
* Provided automatic clarifiers are installed		
m/m = mass		v/v = volume

If heavy fuel oils with analysis data exceeding the above figures are to be used, especially with regard to viscosity and specific gravity, the engine builder should be contacted for advice regarding possible fuel oil system changes.



### Fuel Oil Pipes and Drain Pipes

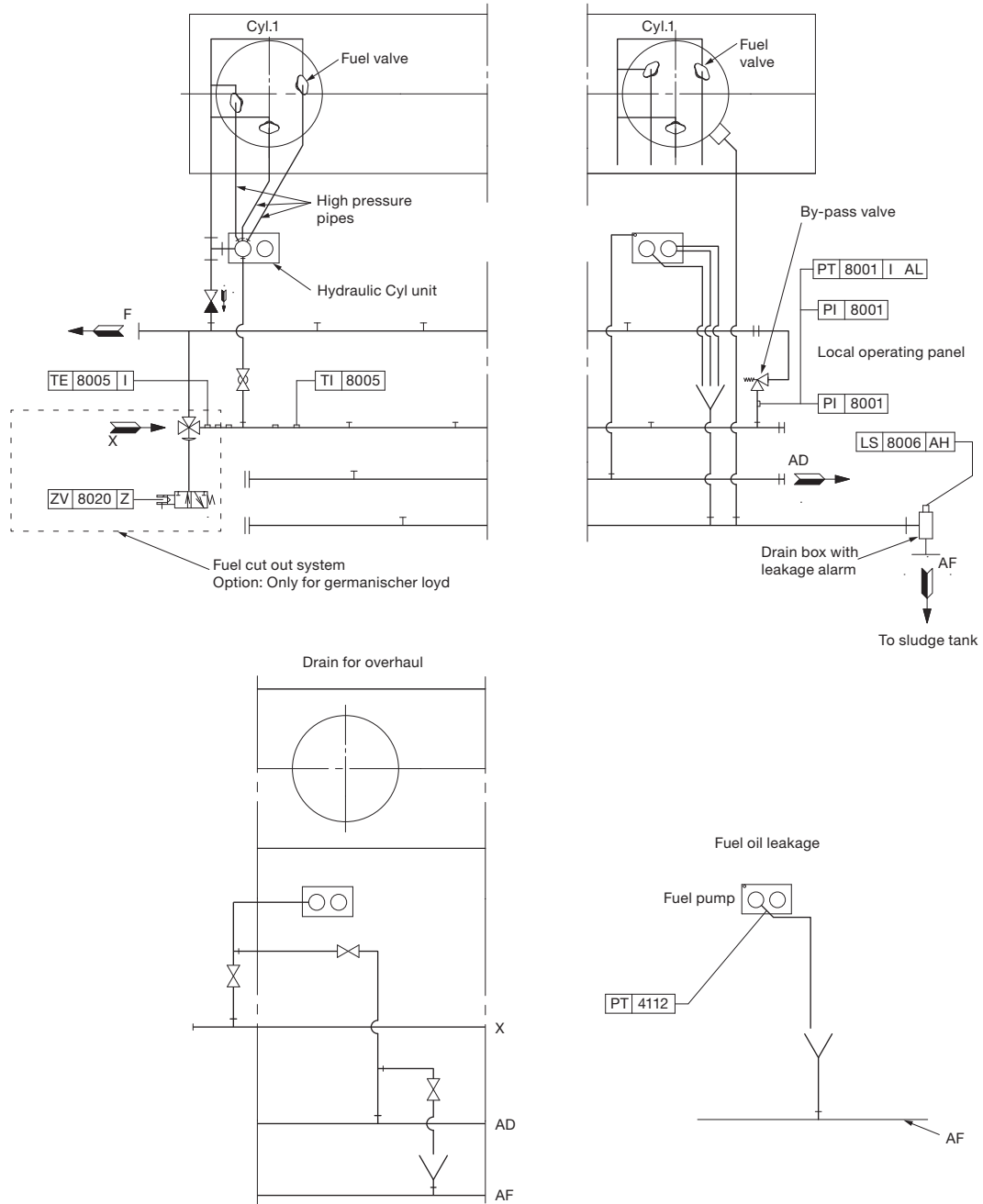

The letters refer to list of 'Counterflanges'

The item No. refer to 'Guidance values automation'

546 95 16-8.1.0b

Fig. 7.03.01: Fuel oil and drain pipes



### Fuel Oil Pipe Insulation

Insulation of fuel oil pipes and fuel oil drain pipes should not be carried out until the piping systems have been subjected to the pressure tests specified and approved by the respective classification society and/or authorities, Fig. 7.04.01.

The directions mentioned below include insulation of hot pipes, flanges and valves with a surface temperature of the complete insulation of maximum 55 °C at a room temperature of maximum 38 °C. As for the choice of material and, if required, approval for the specific purpose, reference is made to the respective classification society.

#### Fuel oil pipes

The pipes are to be insulated with 20 mm mineral wool of minimum 150 kg/m<sup>3</sup> and covered with glass cloth of minimum 400 g/m<sup>2</sup>.

#### Fuel oil pipes and heating pipes together

Two or more pipes can be insulated with 30 mm wired mats of mineral wool of minimum 150 kg/m<sup>3</sup> covered with glass cloth of minimum 400 g/m<sup>2</sup>.

#### Flanges and valves

The flanges and valves are to be insulated by means of removable pads. Flange and valve pads are made of glass cloth, minimum 400 g/m<sup>2</sup>, containing mineral wool stuffed to minimum 150 kg/m<sup>3</sup>.

Thickness of the pads to be:

- Fuel oil pipes ..... 20 mm
- Fuel oil pipes and heating pipes together.... 30 mm

The pads are to be fitted so that they lap over the pipe insulating material by the pad thickness. At flanged joints, insulating material on pipes should not be fitted closer than corresponding to the minimum bolt length.

#### Mounting

Mounting of the insulation is to be carried out in accordance with the supplier's instructions.

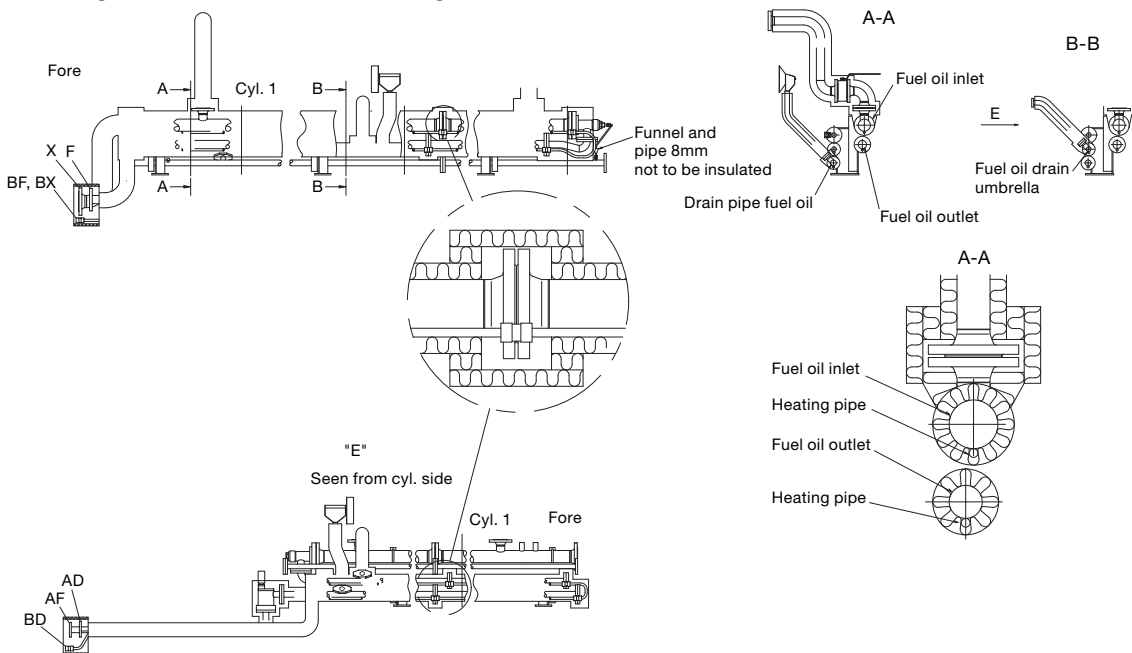
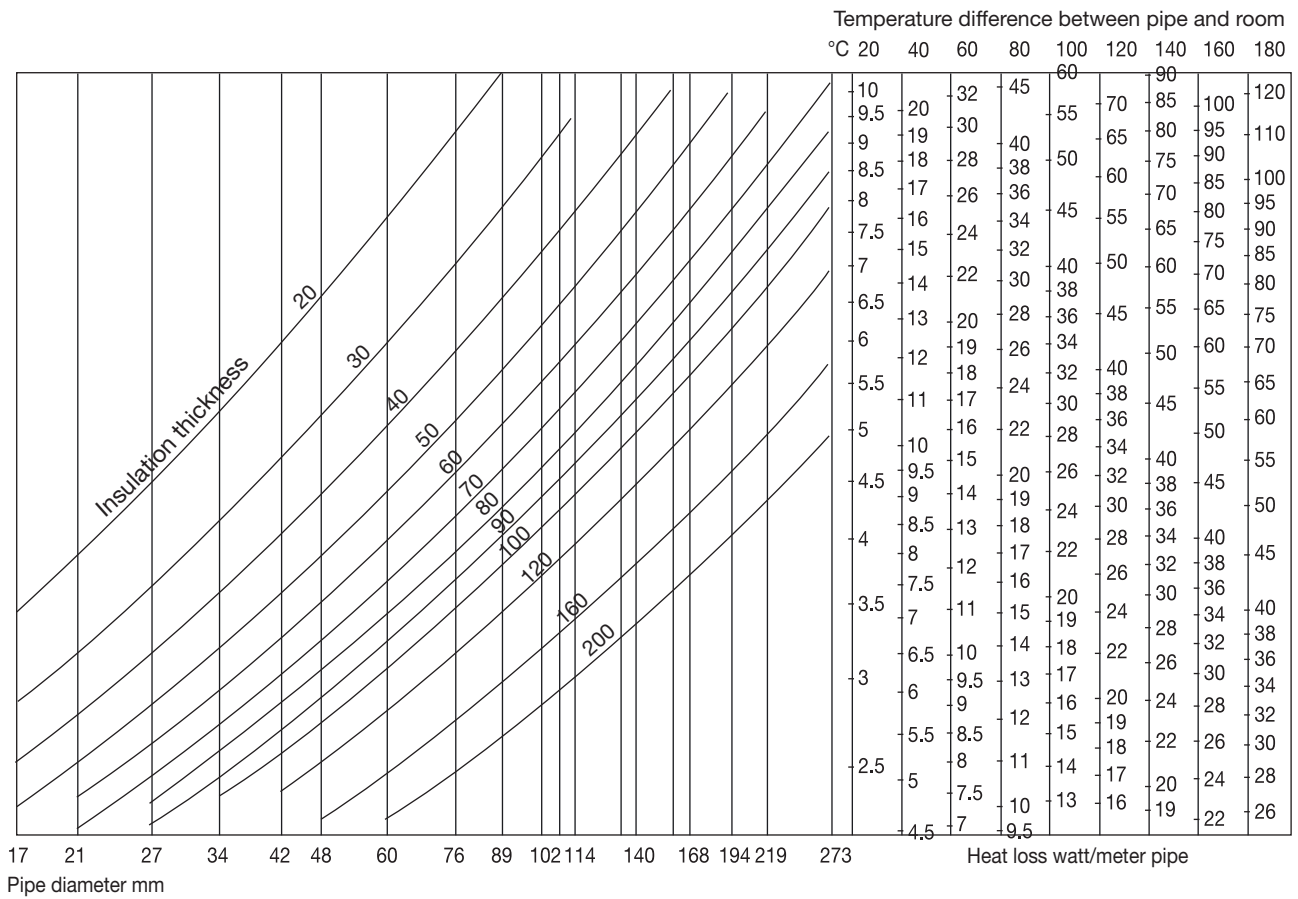

Fig. 7.04.01: Details of fuel oil pipes insulation, option: 4 35 121. Example from 98-50 MC engine

178 50 65 -0.2



### Heat Loss in Piping



178 50 60-2.0

Fig. 7.04.02: Heat loss/Pipe cover



### Fuel Oil Pipe Heat Tracing

The steam tracing of the fuel oil pipes is intended to operate in two situations:

1. When the circulation pump is running, there will be a temperature loss in the piping, see Fig. 7.04.02. This loss is very small, therefore tracing in this situation is only necessary with very long fuel supply lines.
2. When the circulation pump is stopped with heavy fuel oil in the piping and the pipes have cooled down to engine room temperature, as it is not possible to pump the heavy fuel oil. In this situation the fuel oil must be heated to pumping temperature of about 50 °C.

To heat the pipe to pumping level we recommend to use 100 watt leaking/meter pipe.

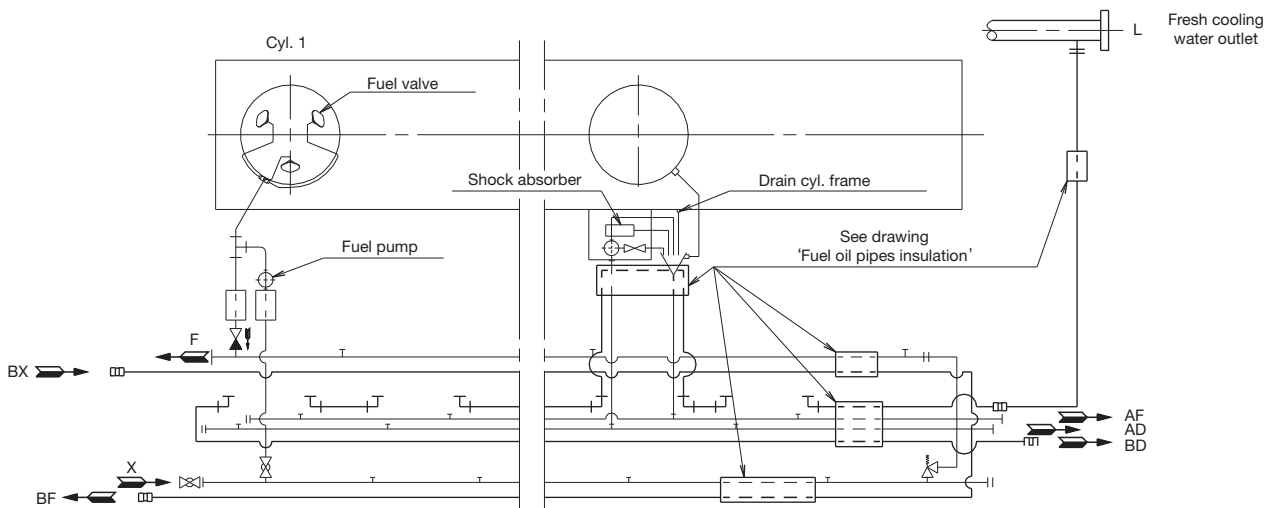

The letters refer to list of 'Counterflanges'

178 50 62-5.0

Fig. 7.04.03: Fuel oil pipe heat tracing

### Fuel Oil and Lubricating Oil Pipe Spray Shields

To fulfill IMO regulations, fuel and oil pipes assemblies are to be secured by spray shields as shown.

To ensure tightness the spray shields are to be applied after pressure test of the pipe system. as shown in Fig. 7.04.04a and b.

To avoid leaks, the spray shields are to be installed after pressure testing of the pipe system.

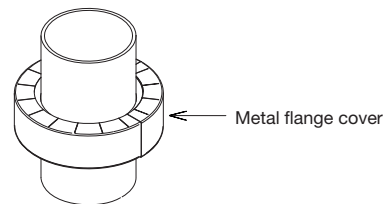

Fig. 7.04.04a: Spray Shields by anti-splashing tape

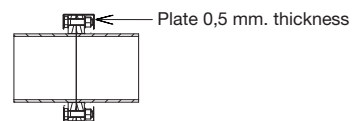

Fig. 7.04.04b: Spray Shields by clamping bands

176 94 23-4.4.0





## Components for Fuel Oil System

### Fuel oil centrifuges

The manual cleaning type of centrifuges are not to be recommended. Centrifuges must be self-cleaning, either with total discharge or with partial discharge.

Distinction must be made between installations for:

- Specific gravities < 0.991 (corresponding to ISO 8217 and British Standard 6843 from RMA to RMH, and CIMAC from A to H-grades)
- Specific gravities > 0.991 and (corresponding to CIMAC K-grades).

For the latter specific gravities, the manufacturers have developed special types of centrifuges, e.g.:

Alfa Laval.....	Alcap
Westfalia.....	Unitrol
Mitsubishi.....	E-Hidens II

The centrifuge should be able to treat approximately the following quantity of oil:

**0.23 litres/kWh**

This figure includes a margin for:

- Water content in fuel oil
- Possible sludge, ash and other impurities in the fuel oil
- Increased fuel oil consumption, in connection with other conditions than ISO standard condition
- Purifier service for cleaning and maintenance.

The size of the centrifuge has to be chosen according to the supplier's table valid for the selected viscosity of the Heavy Fuel Oil. Normally, two centrifuges are installed for Heavy Fuel Oil (HFO), each with adequate capacity to comply with the above recommendation.

A centrifuge for Marine Diesel Oil (MDO) is not a must. However, MAN Diesel & Turbo recommends that at least one of the HFO purifiers can also treat MDO.

If it is decided after all to install an individual purifier for MDO on board, the capacity should be based on the above recommendation, or it should be a centrifuge of the same size as that for HFO.

The *Nominal MCR* is used to determine the total installed capacity. Any derating can be taken into consideration in border-line cases where the centrifuge that is one step smaller is able to cover *Specified MCR*.

### Fuel oil supply pump

This is to be of the screw or gear wheel type.

Fuel oil viscosity, specified.... up to 700 cSt at 50 °C	
Fuel oil viscosity maximum.....	1,000 cSt
Pump head.....	4 bar
Fuel oil flow.....	see 'List of Capacities'
Delivery pressure.....	4 bar
Working temperature.....	100 °C
Minimum temperature.....	50 °C

The capacity stated in 'List of Capacities' is to be fulfilled with a tolerance of: ±0% to +15% and shall also be able to cover the back-flushing, see 'Fuel oil filter'.

### Fuel oil circulating pump

This is to be of the screw or gear wheel type.

Fuel oil viscosity, specified.... up to 700 cSt at 50 °C	
Fuel oil viscosity normal.....	20 cSt
Fuel oil viscosity maximum.....	1,000 cSt
Fuel oil flow.....	see 'List of Capacities'
Pump head.....	6 bar
Delivery pressure.....	10 bar
Working temperature.....	150 °C

The capacity stated in 'List of Capacities' is to be fulfilled with a tolerance of: ±0% to +15% and shall also be able to cover the back-flushing, see 'Fuel oil filter'.

*Pump head is based on a total pressure drop in filter and preheater of maximum 1.5 bar.*



### Fuel Oil Heater

The heater is to be of the tube or plate heat exchanger type.

The required heating temperature for different oil viscosities will appear from the 'Fuel oil heating chart', Fig. 7.05.01. The chart is based on information from oil suppliers regarding typical marine fuels with viscosity index 70-80.

Since the viscosity after the heater is the controlled parameter, the heating temperature may vary, depending on the viscosity and viscosity index of the fuel.

Recommended viscosity meter setting is 10-15 cSt.

- Fuel oil viscosity specified ... up to 700 cSt at 50°C
- Fuel oil flow ..... see capacity of fuel oil circulating pump
- Heat dissipation ..... see 'List of Capacities'
- Pressure drop on fuel oil side ..... maximum 1 bar
- Working pressure ..... 10 bar
- Fuel oil inlet temperature ..... approx. 100 °C
- Fuel oil outlet temperature ..... 150 °C
- Steam supply, saturated ..... 7 bar abs

To maintain a correct and constant viscosity of the fuel oil at the inlet to the main engine, the steam supply shall be automatically controlled, usually based on a pneumatic or an electrically controlled system.

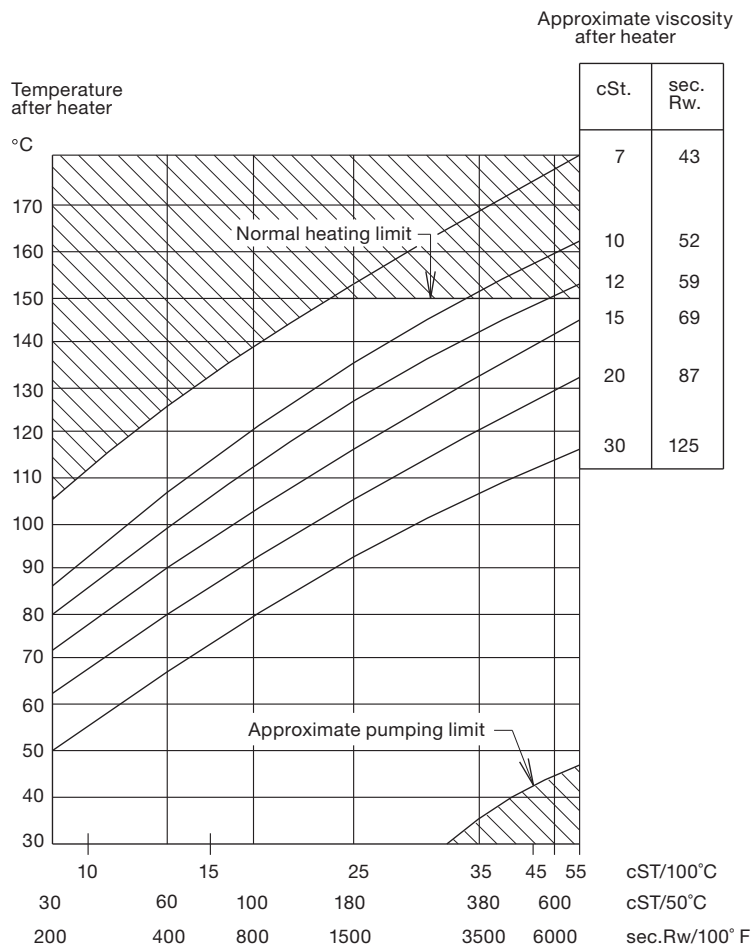

178 06 28-0.1

Fig. 7.05.01: Fuel oil heating chart



Fuel oil filter

The filter can be of the manually cleaned duplex type or an automatic filter with a manually cleaned bypass filter.

If a double filter (duplex) is installed, it should have sufficient capacity to allow the specified full amount of oil to flow through each side of the filter at a given working temperature with a max. 0.3 bar pressure drop across the filter (clean filter).

If a filter with backflushing arrangement is installed, the following should be noted. The required oil flow specified in the 'List of capacities', i.e. the delivery rate of the fuel oil supply pump and the fuel oil circulating pump, should be increased by the amount of oil used for the backflushing, so that the fuel oil pressure at the inlet to the main engine can be maintained during cleaning.

In those cases where an automatically cleaned filter is installed, it should be noted that in order to activate the cleaning process, certain makers of filters require a greater oil pressure at the inlet to the filter than the pump pressure specified. Therefore, the pump capacity should be adequate for this purpose, too.

The fuel oil filter should be based on heavy fuel oil of: 130 cSt at 80 °C = 700 cSt at 50 °C = 7000 sec Redwood I/100 °F.

Fuel oil flow ..... see 'List of capacities'
Working pressure ..... 10 bar
Test pressure..... according to class rule
Absolute fineness..... 50 µm
Working temperature ..... maximum 150 °C
Oil viscosity at working temperature ..... 15 cSt
Pressure drop at clean filter..... maximum 0.3 bar
Filter to be cleaned at a pressure drop of ..... maximum 0.5 bar

Note:

Absolute fineness corresponds to a nominal fineness of approximately 35 µm at a retaining rate of 90%.

The filter housing shall be fitted with a steam jacket for heat tracing.

Fuel oil venting box

The design of the Fuel oil venting box is shown in Fig. 7.05.02. The size is chosen according to the maximum flow of the fuel oil circulation pump, which is listed in section 6.03.

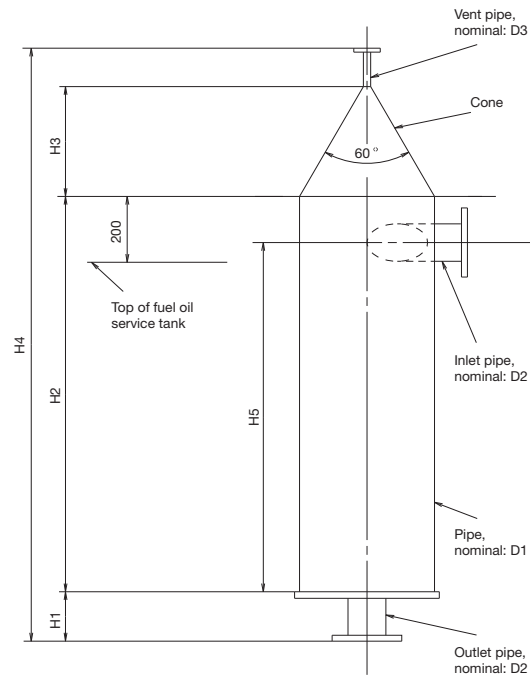

178 38 39-3.3

Table with 9 columns: Flow m³/h, Q (max.)\*, D1, D2, D3, H1, H2, H3, H4, H5. It lists various flow rates and their corresponding dimensions.

\* The maximum flow of the fuel oil circulation pump

Fig. 07.05.02: Fuel oil venting box

Flushing of the fuel oil system

Before starting the engine for the first time, the system on board has to be flushed in accordance with MAN Diesel & Turbos recommendations 'Flushing of Fuel Oil System' which is available on request.



## Water In Fuel Emulsification

The emulsification of water into the fuel oil reduces the NO<sub>x</sub> emission with about 1% per 1% water added to the fuel up to about 20% without modification of the engine fuel injection equipment.

A Water In Fuel emulsion (WIF) mixed for this purpose and based on Heavy Fuel Oil (HFO) is stable for a long time, whereas a WIF based on Marine Diesel Oil is only stable for a short period of time unless an emulsifying agent is applied.

As both the MAN B&W two-stroke main engine and the MAN GenSets are designed to run on emulsified HFO, it can be used for a common system.

It is supposed below, that both the main engine and GenSets are running on the same fuel, either HFO or a homogenised HFO-based WIF.

Special arrangements are available on request for a more sophisticated system in which the GenSets can run with or without a homogenised HFO-based WIF, if the main engine is running on that.

Please note that the fuel pump injection capacity shall be confirmed for the main engine as well as the GenSets for the selected percentage of water in the WIF.

### Temperature and pressure

When water is added by emulsification, the fuel viscosity increases. In order to keep the injection viscosity at 10-15 cSt and still be able to operate on up to 700 cSt fuel oil, the heating temperature has to be increased to about 170 °C depending on the water content.

The higher temperature calls for a higher pressure to prevent cavitation and steam formation in the system. The inlet pressure is thus set to 13 bar.

In order to avoid temperature chock when mixing water into the fuel in the homogeniser, the water inlet temperature is to be set to 70-90 °C.

### Safety system

In case the pressure in the fuel oil line drops, the water homogenised into the Water In Fuel emulsion will evaporate, damaging the emulsion and creating supply problems. This situation is avoided by installing a third, air driven supply pump, which keeps the pressure as long as air is left in the tank 'S', see Fig. 7.06.01.

Before the tank 'S' is empty, an alarm is given and the drain valve is opened, which will drain off the WIF and replace it with HFO or diesel oil from the service tank.

The drain system is kept at atmospheric pressure, so the water will evaporate when the hot emulsion enters the safety tank. The safety tank shall be designed accordingly.

### Impact on the auxiliary systems

Please note that if the engine operates on Water In Fuel emulsion (WIF), in order to reduce the NO<sub>x</sub> emission, the exhaust gas temperature will decrease due to the reduced air / exhaust gas ratio and the increased specific heat of the exhaust gas.

Depending on the water content, this will have an impact on the calculation and design of the following items:

- Freshwater generators
- Energy for production of freshwater
- Jacket water system
- Waste heat recovery system
- Exhaust gas boiler
- Storage tank for freshwater

For further information about emulsification of water into the fuel and use of Water In Fuel emulsion (WIF), please refer to our publication titled:

*Exhaust Gas Emission Control Today and Tomorrow*

The publication is available at [www.marine.man.eu](http://www.marine.man.eu)  
→ 'Two-Stroke' → 'Technical Papers'

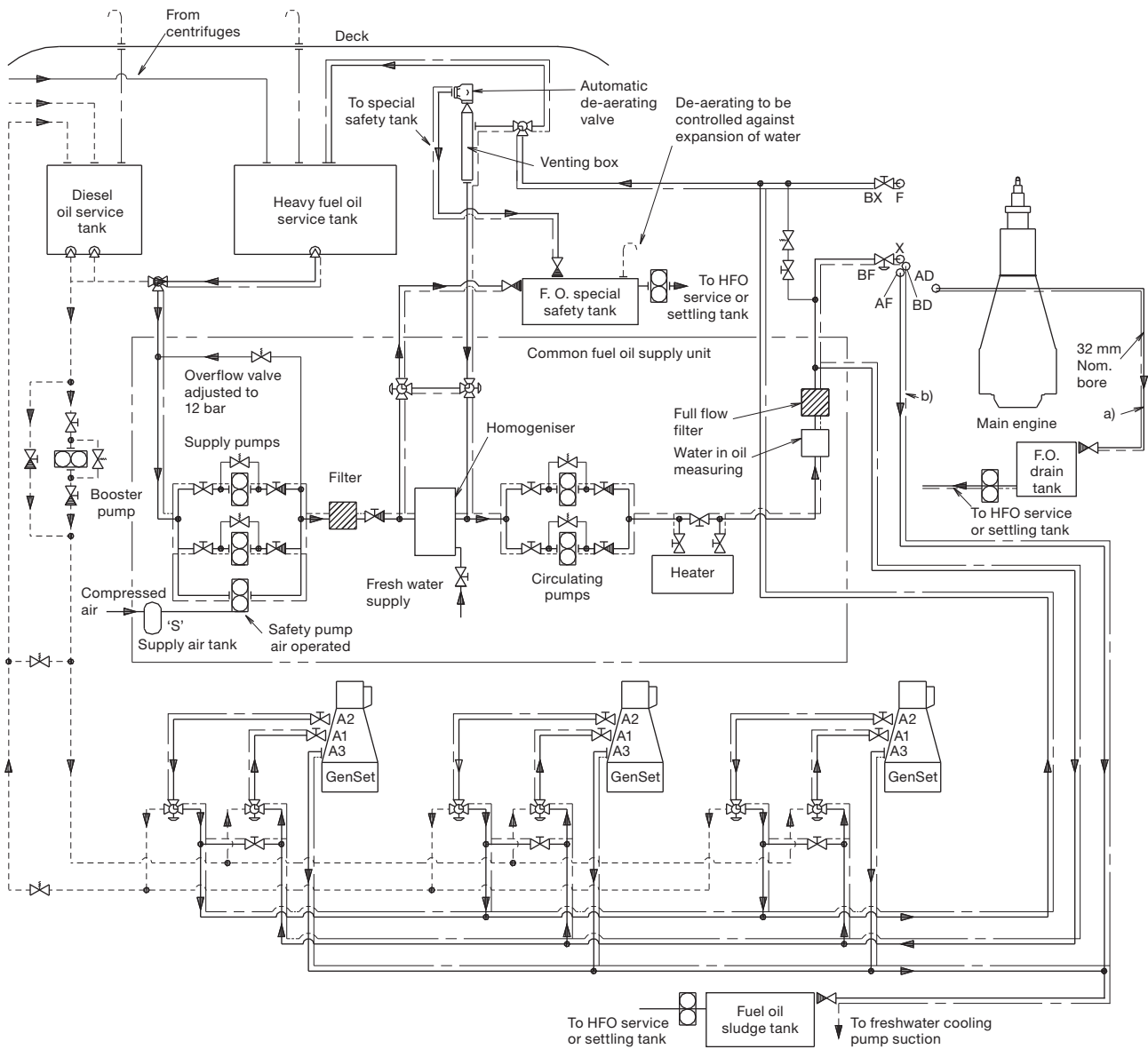

- - - - - Diesel oil  
 \_\_\_\_\_ Heavy fuel oil  
 = = = = = Heated pipe with insulation

Number of auxiliary engines, pumps, coolers, etc. are subject to alterations according to the actual plant specification.

- a) Tracing fuel oil lines: Max. 150 °C
- b) Tracing fuel oil drain lines: Max. 90 °C, min. 50 °C for installations with jacket cooling water

The letters refer to the list of 'Counterflanges'.

198 99 01-8.3

Fig. 7.06.01: System for emulsification of water into the fuel common to the main engine and MAN GenSets



**MAN B&W**

---

# Lubricating Oil

**8**

---

**MAN Diesel**



### Lubricating and Cooling Oil System

The lubricating oil is pumped from a bottom tank by means of the main lubricating oil pump to the lubricating oil cooler, a thermostatic valve and, through a full-flow filter, to the engine inlet RU, Fig. 8.01.01.

RU lubricates main bearings, thrust bearing, axial vibration damper, piston cooling, crosshead bearings, crankpin bearings. It also supplies oil to the Hydraulic Power Supply unit and to moment compensator and torsional vibration damper.

From the engine, the oil collects in the oil pan, from where it is drained off to the bottom tank, see Fig. 8.06.01a and b 'Lubricating oil tank, with cofferdam'. By class demand, a cofferdam must be placed underneath the lubricating oil tank.

The engine crankcase is vented through 'AR' by a pipe which extends directly to the deck. This pipe

has a drain arrangement so that oil condensed in the pipe can be led to a drain tank, see details in Fig. 8.07.01.

Drains from the engine bedplate 'AE' are fitted on both sides, see Fig. 8.07.02 'Bedplate drain pipes'.

For external pipe connections, we prescribe a maximum oil velocity of 1.8 m/s.

### Lubrication of turbochargers

Turbochargers with slide bearings are normally lubricated from the main engine system. AB is outlet from the turbocharger, see Figs. 8.03.01 to 8.03.04.

Figs. 8.03.01 to 8.03.04 show the lube oil pipe arrangements for different turbocharger makes.

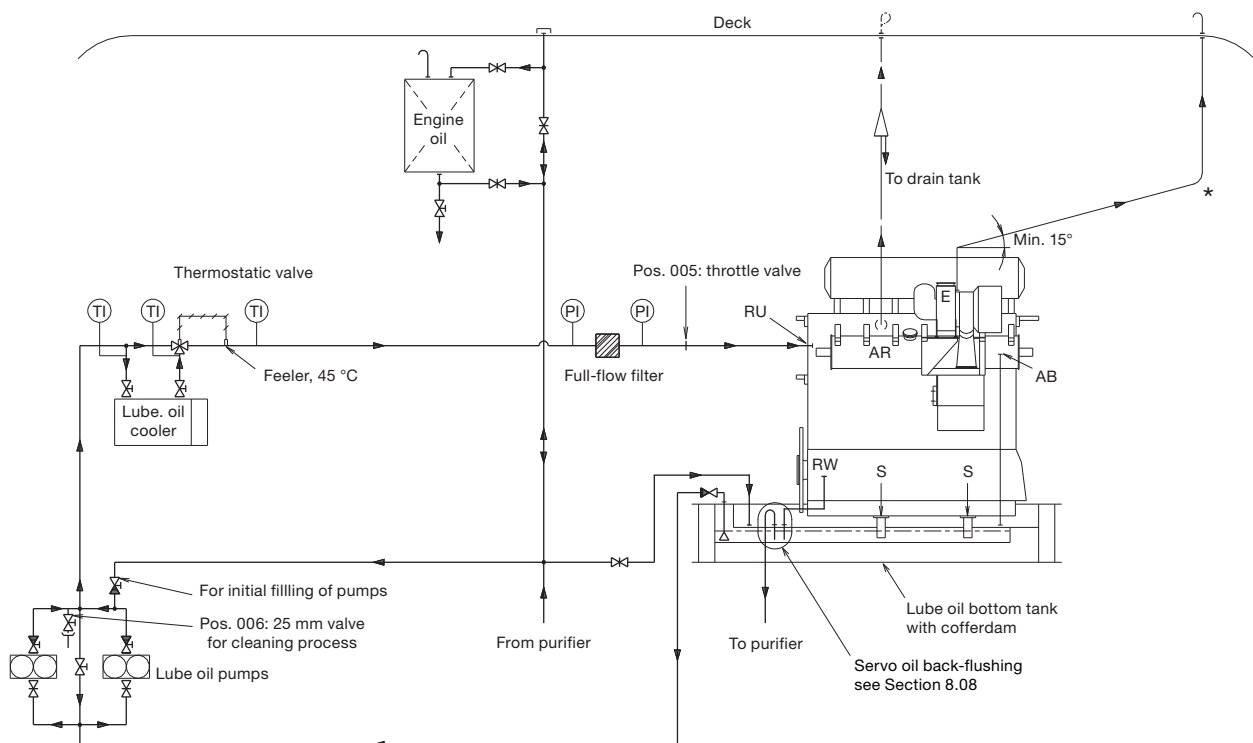

The letters refer to list of 'Counterflanges'  
\* Venting for MAN or Mitsubishi turbochargers only

Fig. 8.01.01 Lubricating and cooling oil system

198 99 84-4.5



## Hydraulic Power Supply Unit

Hydraulic power for the ME hydraulic-mechanical system for activation of the fuel injection and the exhaust valve is supplied by the Hydraulic Power Supply (HPS) unit.

As hydraulic medium, normal lubricating oil is used, as standard taken from the engine's main lubricating oil system and filtered in the HPS unit.

### HPS connection to lubrication oil system

Internally on the engine, the system oil inlet RU is connected to the HPS unit which supplies the hydraulic oil to the Hydraulic Cylinder Units (HCUs). See Figs. 16.01.02a and 16.01.02b.

RW is the oil outlet from the automatic backflushing filter.

The hydraulic oil is supplied to the Hydraulic Cylinder Units (HCU) located at each cylinder, where it is diverted to the electronic Fuel Injection system, and to the electronic exhaust Valve Activation (FIVA) system, which perform the fuel injection and opens the exhaust valve. The exhaust valve is closed by the conventional 'air spring'.

The electronic signals to the FIVA valves are given by the Engine Control System, see Chapter 16, Engine Control System (ECS).

### HPS configurations

The HPS pumps are driven either mechanically by the engine (via a step-up gear from the crankshaft) or electrically.

With mechanically driven pumps, the HPS unit consists of:

- an automatic and a redundant filter
- three to five engine driven main pumps
- two electrically driven start-up pumps
- a safety and accumulator block

as shown in Fig. 8.02.01.

With electrically driven pumps, the HPS unit differs in having a total of three pumps which serve as combined main and start-up pumps.

The HPS unit is mounted on the engine no matter how its pumps are driven.

### HPS unit types

Altogether, three HPS configurations are available:

- **STANDARD** mechanically driven HPS, EoD: 4 40 160, with mechanically driven main pumps and start-up pumps with capacity sufficient to deliver the start-up pressure only. The engine cannot run with all engine driven main pumps out of operation, whereas 66% engine load is available in case one main pump is out
- **COMBINED** mechanically driven HPS unit, EoD: 4 40 167 with electrically driven start-up pumps with back-up capacity. In this case, at least 15% engine power is available as back-up power if all engine driven pumps are out
- **electrically driven HPS**, EoD: 4 40 161, with 66% engine load available in case one pump is out.

The electric power consumption of the electrically driven pumps should be taken into consideration in the specification of the auxiliary machinery capacity.





### Hydraulic Power Supply Unit, Engine Driven, and Lubricating Oil Pipes

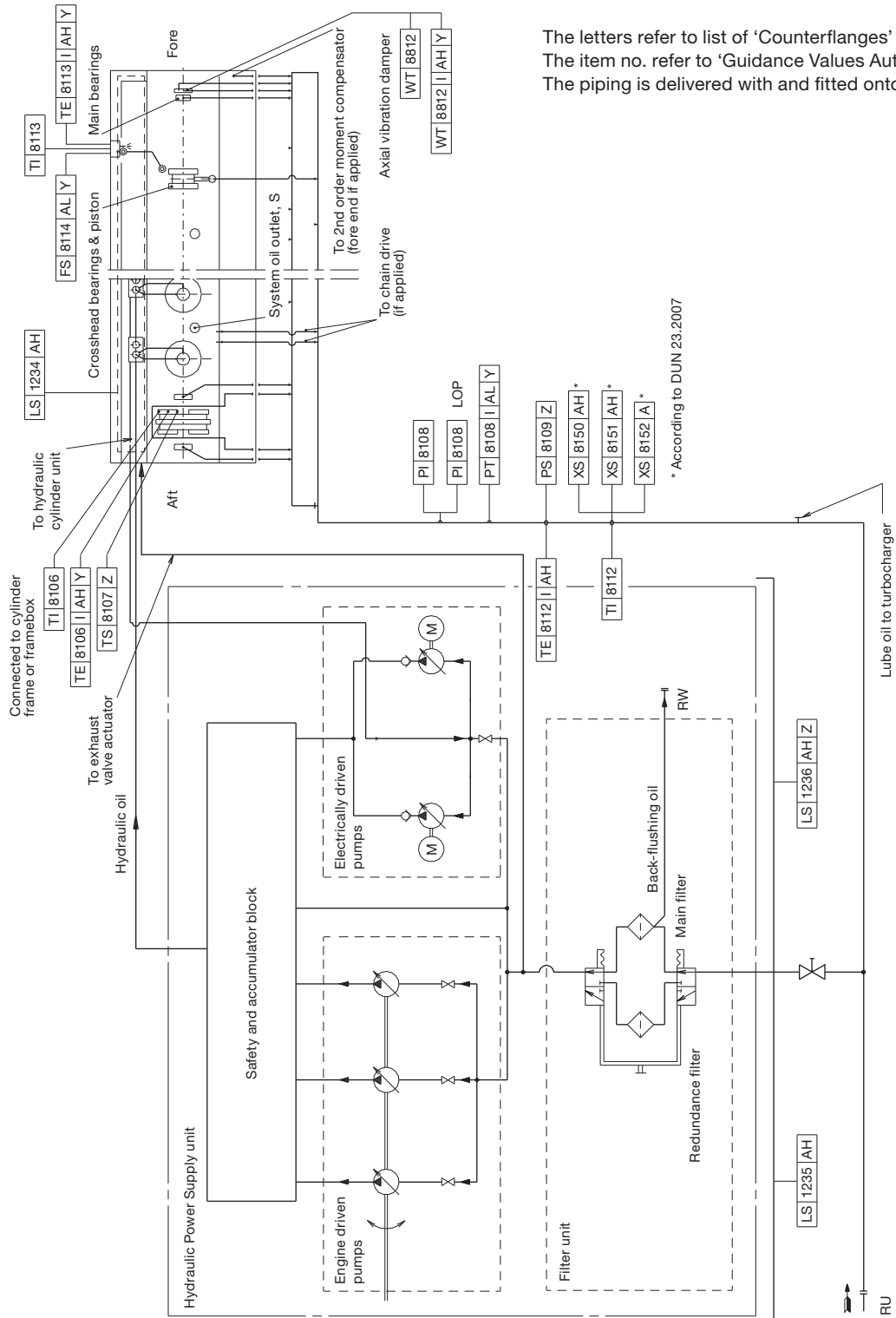

The letters refer to list of 'Counterflanges'  
 The item no. refer to 'Guidance Values Automation'  
 The piping is delivered with and fitted onto the engine

\* According to DUN 23.2007

178 48 13-4.4a

Fig. 8.02.01: Engine driven hydraulic power supply unit and lubricating oil pipes



### Lubricating Oil Pipes for Turbochargers

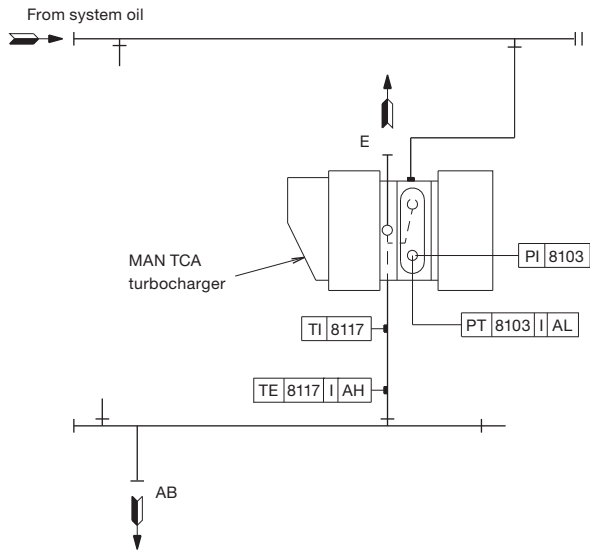

121 14 96-6.1.2

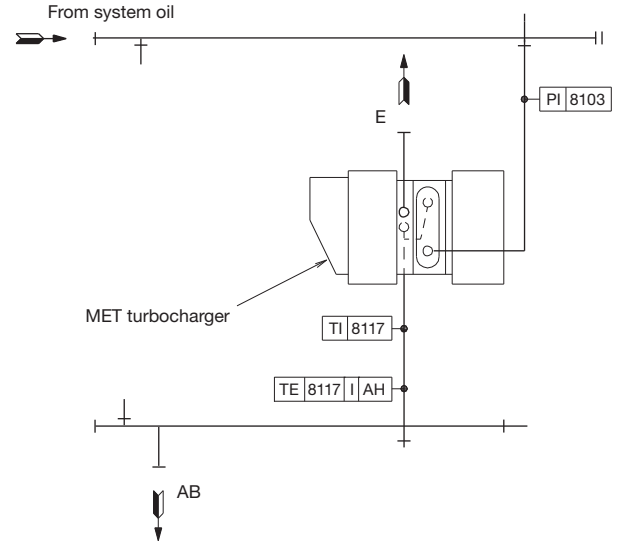

126 40 87-1.2.0

Fig. 8.03.01: MAN turbocharger type TCA

Fig. 8.03.03: Mitsubishi turbocharger type MET

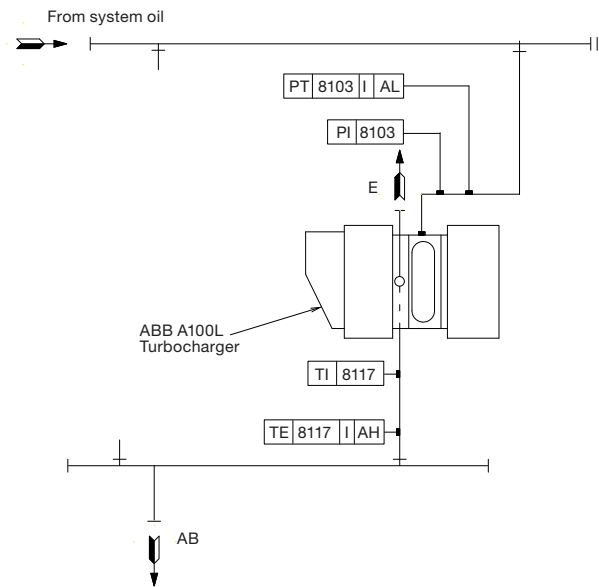

524 26 81-4.0.0

Fig. 8.03.03: ABB turbocharger type A100L

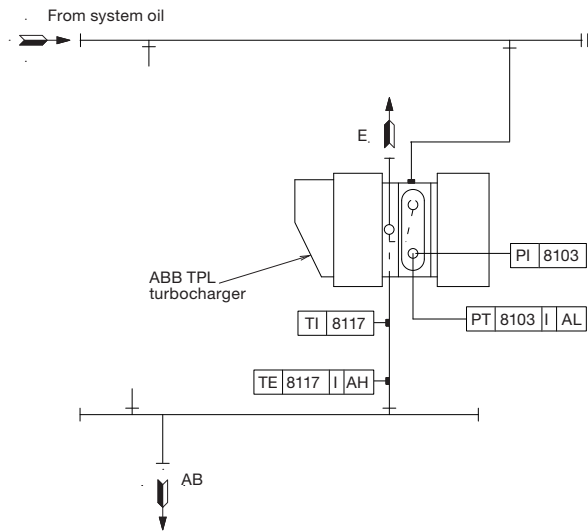

515 85 30-3.1.0

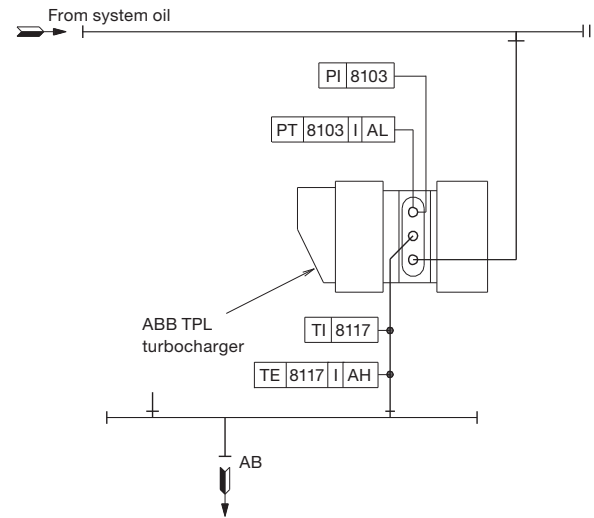

126 40 85-8.3.0

Fig. 8.03.02: ABB turbocharger type TPL85B14-16 / TPL 91B12

Fig. 8.03.02: ABB turbocharger type TPL65B12 - TPL85B12



## Lubricating Oil Consumption, Centrifuges and List of Lubricating Oils

### Lubricating oil consumption

The system oil consumption varies for different engine sizes and operational patterns. Typical consumptions are in the range from

**negligible to 0.1 g/kWh**

subject to load, maintenance condition and installed equipment like PTO.

### Lubricating oil centrifuges

Automatic centrifuges are to be used, either with total discharge or partial discharge.

The nominal capacity of the centrifuge is to be according to the supplier's recommendation for lubricating oil, based on the figure:

**0.136 litre/kWh**

The Nominal MCR is used as the total installed power.

Further information about lubricating oil qualities is available in our publication:

*Guidelines for Fuels and Lubes Purchasing*

The publication is available at [www.marine.man.eu](http://www.marine.man.eu) → 'Two-Stroke' → 'Technical Papers'.

### List of lubricating oils

The circulating oil (lubricating and cooling oil) must be of the rust and oxidation inhibited type of oil of SAE 30 viscosity grade.

In short, MAN Diesel and Turbo recommends the use of system oils with the following main properties:

- SAE 30 viscosity grade
- BN level 5-10
- adequately corrosion and oxidation inhibited
- adequate detergency and dispersancy.

The adequate dispersion and detergent properties are in order to keep the crankcase and piston cooling spaces clean of deposits.

Alkaline circulating oils are generally superior in this respect.

The major international system oil brands listed below have been tested in service with acceptable results. Some of the oils have also given satisfactory service results during long-term operation on MAN B&W engines running on heavy fuel oil (HFO).

Company	Circulating oil SAE 30, BN 5-10
Aegean	Alfasys 305
BP	OE-HT 30
Castrol	CDX 30
Chevron	Veritas 800 Marine 30
ExxonMobil	Mobilgard 300
Gulf Oil Marine	GulfSea Superbear 3006
Lukoil	Navigo 6 SO
JX	Marine S30
Shell	Melina S 30
Sinopec	System Oil 3005
Total	Atlanta Marine D3005

Oils from other companies can be equally suitable. Further information can be obtained from the engine builder or MAN Diesel & Turbo, Copenhagen.



### Flushing of lubricating oil components and piping system at the shipyard

During installation of the lubricating oil system for the main engine, it is important to minimise or eliminate foreign particles in the system. This is done as a final step onboard the vessel by flushing the lubricating oil components and piping system of the MAN B&W main engine types ME/ME-C/ME-B/-GI before starting the engine.

At the shipyard, the following main points should be observed during handling and flushing of the lubricating oil components and piping system:

- **Before and during installation**

Components delivered from subsuppliers, such as pumps, coolers and filters, are expected to be clean and rust protected. However, these must be spot-checked before being connected to the piping system.

All piping must be 'finished' in the workshop before mounting onboard, i.e. all internal welds must be ground and piping must be acid-treated followed by neutralisation, cleaned and corrosion protected.

Both ends of all pipes must be closed/sealed during transport.

Before final installation, carefully check the inside of the pipes for rust and other kinds of foreign particles.

Never leave a pipe end uncovered during assembly.

- **Bunkering and filling the system**

Tanks must be cleaned manually and inspected before filling with oil.

When filling the oil system, MAN Diesel & Turbo recommends that new oil is bunkered through 6 µm fine filters, or that a purifier system is used. New oil is normally delivered with a cleanliness level of XX/23/19 according to ISO 4406 and, therefore, requires further cleaning to meet our specification.

- **Flushing the piping with engine bypass**

When flushing the system, the first step is to bypass the main engine oil system. Through temporary piping and/or hosing, the oil is circulated through the vessel's system and directly back to the main engine oil sump tank.

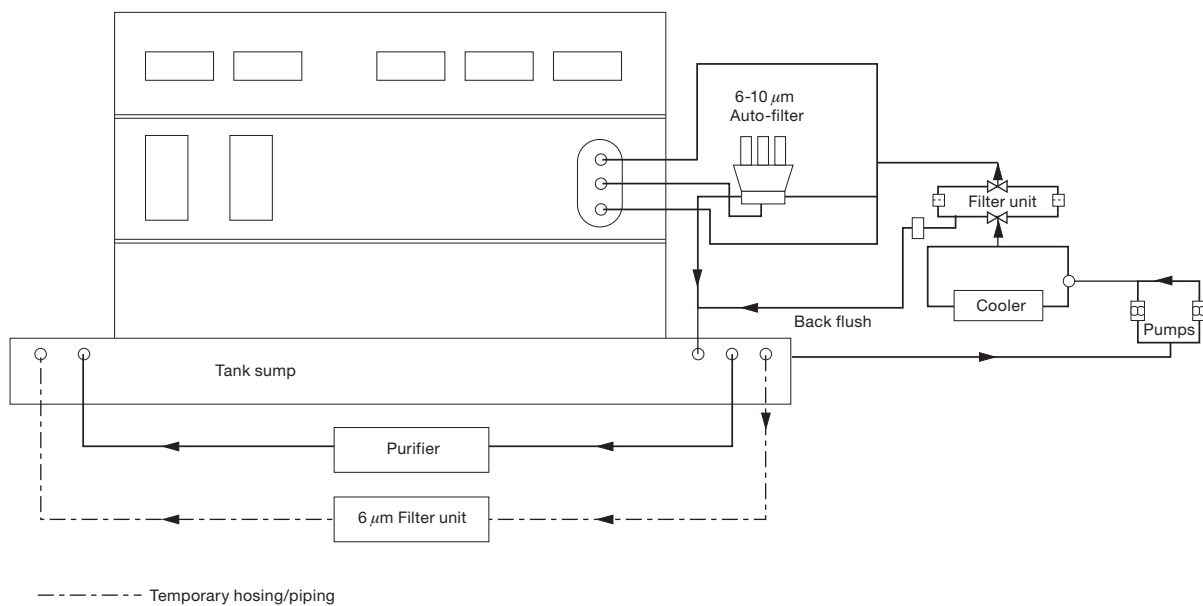

178 61 99-7.0

Fig. 8.05.01: Lubricating oil system with temporary hosing/piping for flushing at the shipyard



If the system has been out of operation, unused for a long time, it may be necessary to spot-check for signs of corrosion in the system. Remove end covers, bends, etc., and inspect accordingly.

It is important during flushing to keep the oil warm, approx 60 °C, and the flow of oil as high as possible. For that reason it may be necessary to run two pumps at the same time.

- **Filtering and removing impurities**

In order to remove dirt and impurities from the oil, it is essential to run the purifier system during the complete flushing period and/or use a bypass unit with a 6 µm fine filter and sump-to-sump filtration, see Fig. 8.05.01.

Furthermore, it is recommended to reduce the filter mesh size of the main filter unit to 10-25 µm (to be changed again after sea trial) and use the 6 µm fine filter already installed in the auto-filter for this temporary installation, see Fig. 8.05.01. This can lead to a reduction of the flushing time.

The flushing time depends on the system type, the condition of the piping and the experience of the yard. (15 to 26 hours should be expected).

- **Cleanliness level, measuring kit and flushing log**

MAN Diesel & Turbo specifies ISO 4406 XX/16/13 as accepted cleanliness level for the ME/ME-C/ME-B/-GI hydraulic oil system, and ISO 4406 XX/19/15 for the remaining part of the lubricating oil system.

The amount of contamination contained in system samples can be estimated by means of the Pall Fluid Contamination Comparator combined with the Portable Analysis Kit, HPCA-Kit-0, which is used by MAN Diesel & Turbo. This kit and the Comparator included is supplied by Pall Corporation, USA, [www.pall.com](http://www.pall.com)

It is important to record the flushing condition in statements to all inspectors involved. The MAN Diesel & Turbo Flushing Log form, which is available on request, or a similar form is recommended for this purpose.

- **Flushing the engine oil system**

The second step of flushing the system is to flush the complete engine oil system. The procedure depends on the engine type and the condition in which the engine is delivered from the engine builder. For detailed information we recommend contacting the engine builder or MAN Diesel & Turbo.

- **Inspection and recording in operation**

Inspect the filters before and after the sea trial.

During operation of the oil system, check the performance and behaviour of all filters, and note down any abnormal condition. Take immediate action if any abnormal condition is observed. For instance, if high differential pressure occurs at short intervals, or in case of abnormal back flushing, check the filters and take appropriate action.

Further information and recommendations regarding flushing, the specified cleanliness level and how to measure it, and how to use the NAS 1638 oil cleanliness code as an alternative to ISO 4406, are available from MAN Diesel & Turbo.



### Lubricating oil outlet

A protecting ring position 1-4 is to be installed if required, by class rules, and is placed loose on the tanktop and guided by the hole in the flange.

In the vertical direction it is secured by means of screw position 4, in order to prevent wear of the rubber plate.

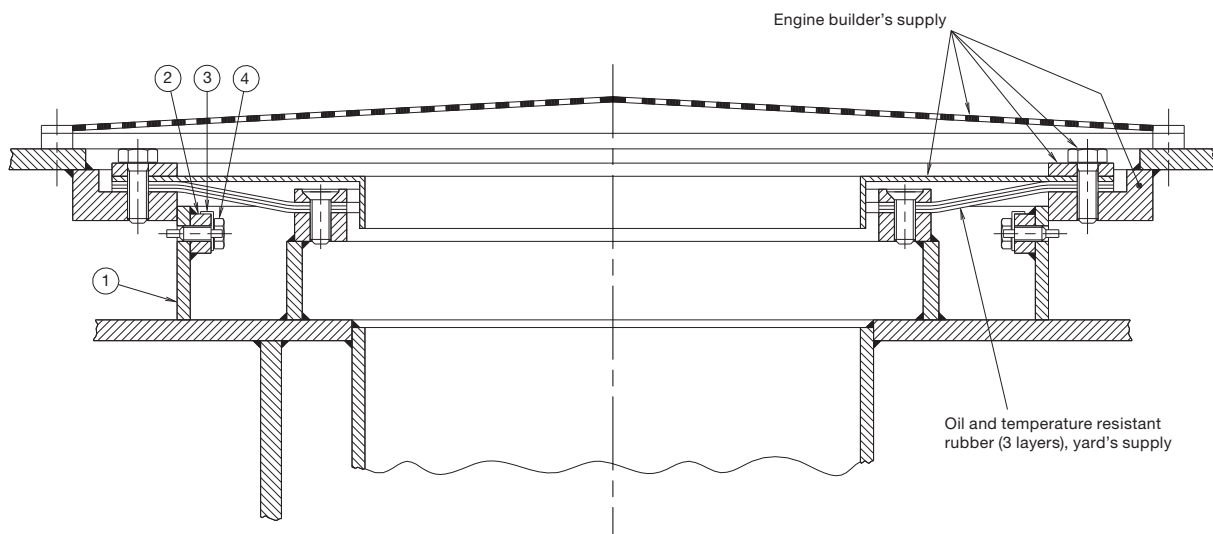

178 07 41-6.1

Fig. 8.05.02: Lubricating oil outlet



### Lubricating Oil Tank

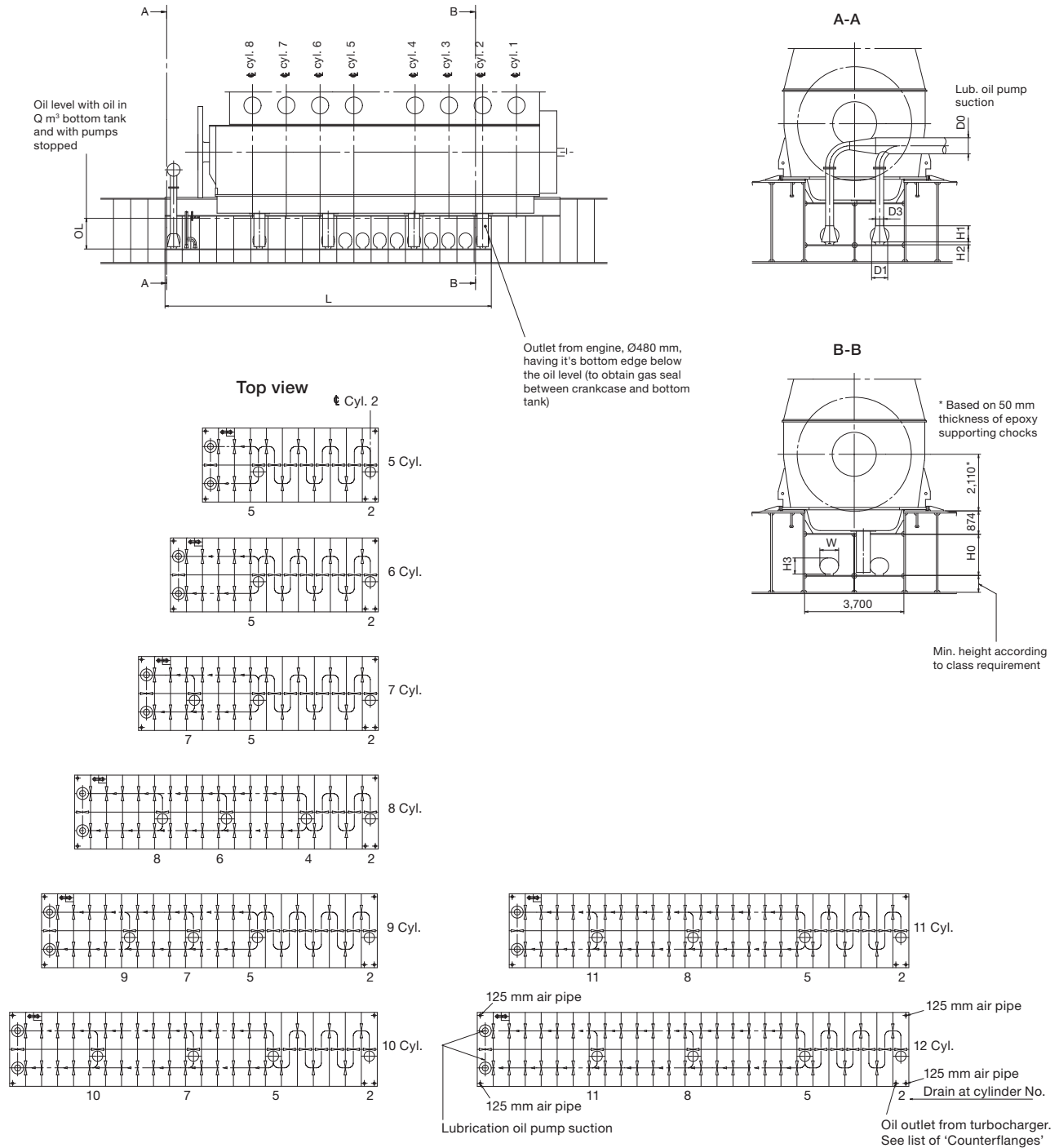

079 62 82-5.0.0

Fig. 8.06.01a: Lubricating oil tank, with cofferdam



**Note:**

When calculating the tank heights, allowance has not been made for the possibility that a quantity of oil in the lubricating oil system outside the engine may be returned to the bottom tank, when the pumps are stopped.

If the system outside the engine is so designed that an amount of the lubricating oil is drained back to the tank, when the pumps are stopped, the height of the bottom tank indicated in Table 8.06.01b has to be increased to include this quantity.

Cyl. No.	Drain at Cyl. No.	D0	D1	D3	H0	H1	H2	H3	W	L	OL	Qm <sup>3</sup>
5	2-5	350	472	2 x 250	1,280	475	95	600	700	8,800	1,180	38.4
6	2-5	375	550	2 x 275	1,350	550	110	600	700	10,400	1,250	48.1
7	2-5-7	400	550	2 x 275	1,430	550	110	600	700	1,200	1,330	59.1
8	2-4-6-8	425	600	2 x 300	1,530	600	110	600	700	15,200	1,430	80.4
9	2-5-7-9	425	600	2 x 300	1,620	600	110	600	800	16,800	1,520	94.5
10	2-5-7-10	450	650	2 x 325	1,700	650	120	600	800	18,400	1,600	108.9
11	2-5-8-11	475	700	2 x 350	1,800	700	130	700	900	20,000	1,700	125.8
12	2-5-8-11	500	700	2 x 375	1,900	700	130	700	900	21,600	1,800	143.9

Table 8.06.01b: Lubricating oil tank, with cofferdam

If space is limited, however, other solutions are possible. Minimum lubricating oil bottom tank volume (m<sup>3</sup>) is:

5 cyl.	6 cyl.	7 cyl.	8 cyl.
31.9	36.7	41.4	46.1

9 cyl.	10 cyl.	11 cyl.	12 cyl.
51.1	55.6	61.1	70.6

**Lubricating oil tank operating conditions**

The lubricating oil bottom tank complies with the rules of the classification societies by operation under the following conditions:

Angle of inclination, degrees			
Athwartships		Fore and aft	
Static	Dynamic	Static	Dynamic
15	22.5	5	7.5



### Crankcase Venting and Bedplate Drain Pipes

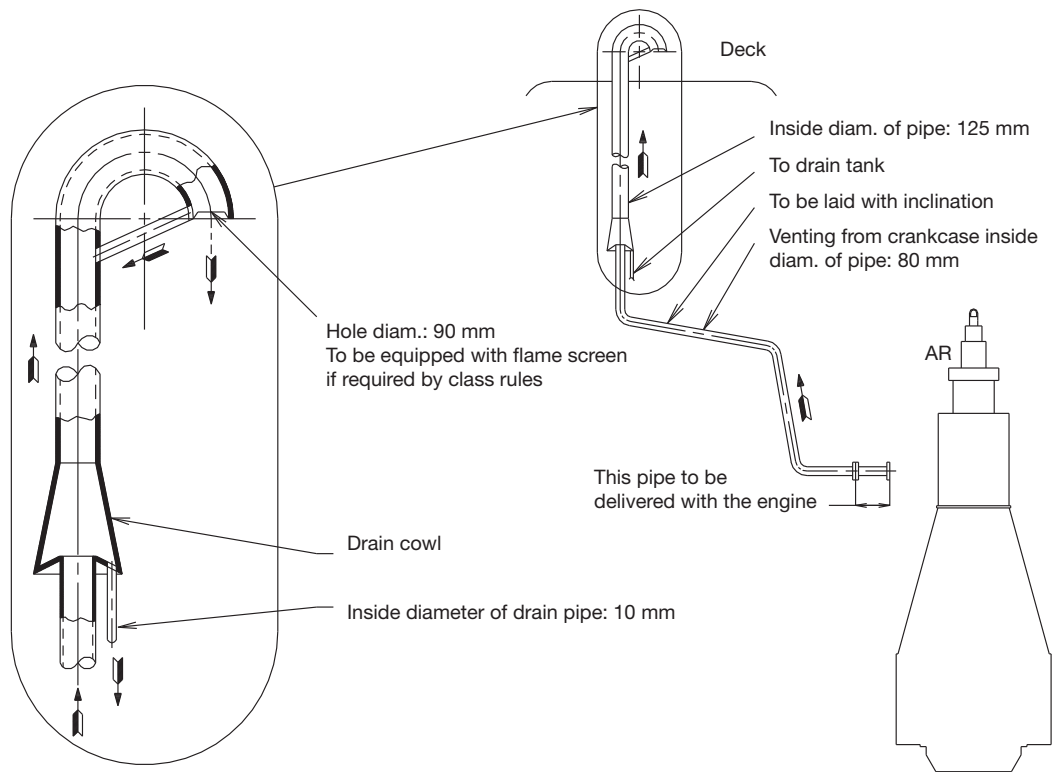

198 97 10-1.4a

Fig. 8.07.01: Crankcase venting

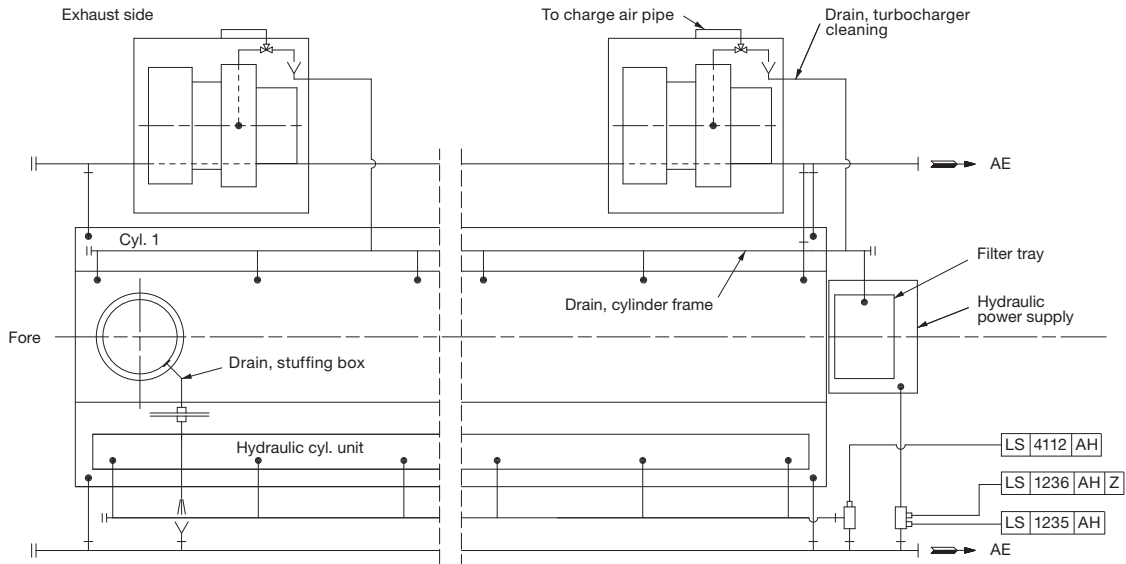

525 29 54-1.3.0

Fig. 8.07.02a: Bedplate drain pipes, aft-mounted HPS: 6-8K98ME/ME-C7/8, 5-9S90ME-C9, 6-8S90ME-C8 and 6-8K90ME-C6

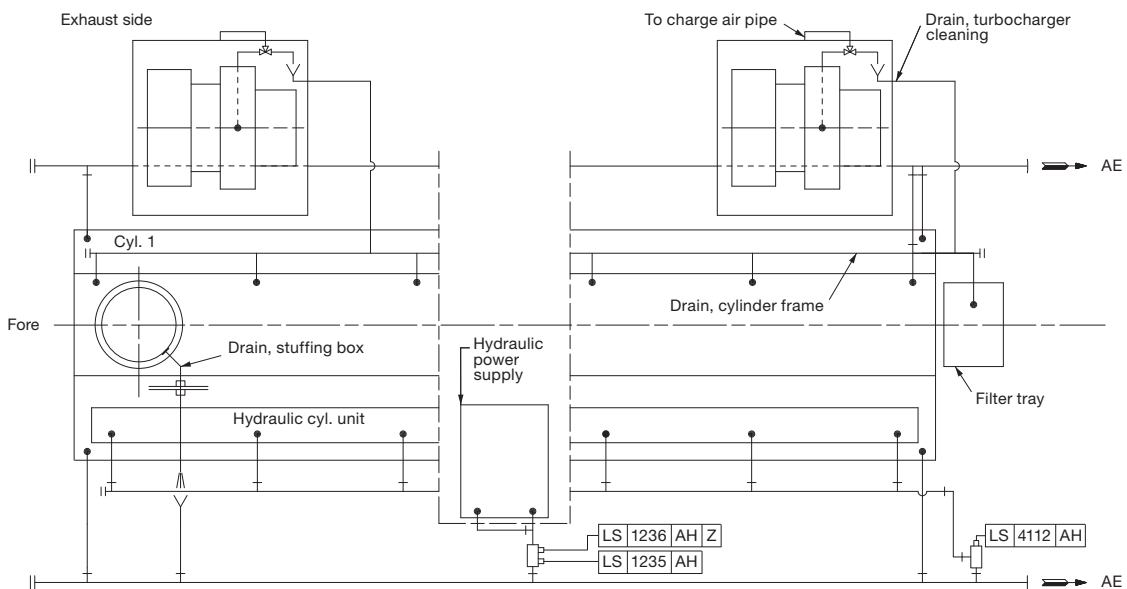

525 18 57-6.0.0

Fig. 8.07.02b: Bedplate drain pipes, center-mounted HPS: 8-14K98ME/ME-C6/7, 10-14S90ME-C9, 9S90ME-C8 and 9-12K90ME-C6



### Engine and Tank Venting to the Outside Air

#### Venting of engine plant equipment separately

The various tanks, engine crankcases and turbochargers should be provided with sufficient venting to the outside air.

MAN Diesel & Turbo recommends to vent the individual components directly to outside air above deck by separate venting pipes as shown in Fig. 8.07.03a.

It is not recommended to join the individual venting pipes in a common venting chamber as shown in Fig. 8.07.03b.

In order to avoid condensed oil (water) from blocking the venting, all vent pipes must be vertical or laid with an inclination.

Additional information on venting of tanks is available from MAN Diesel & Turbo, Copenhagen.

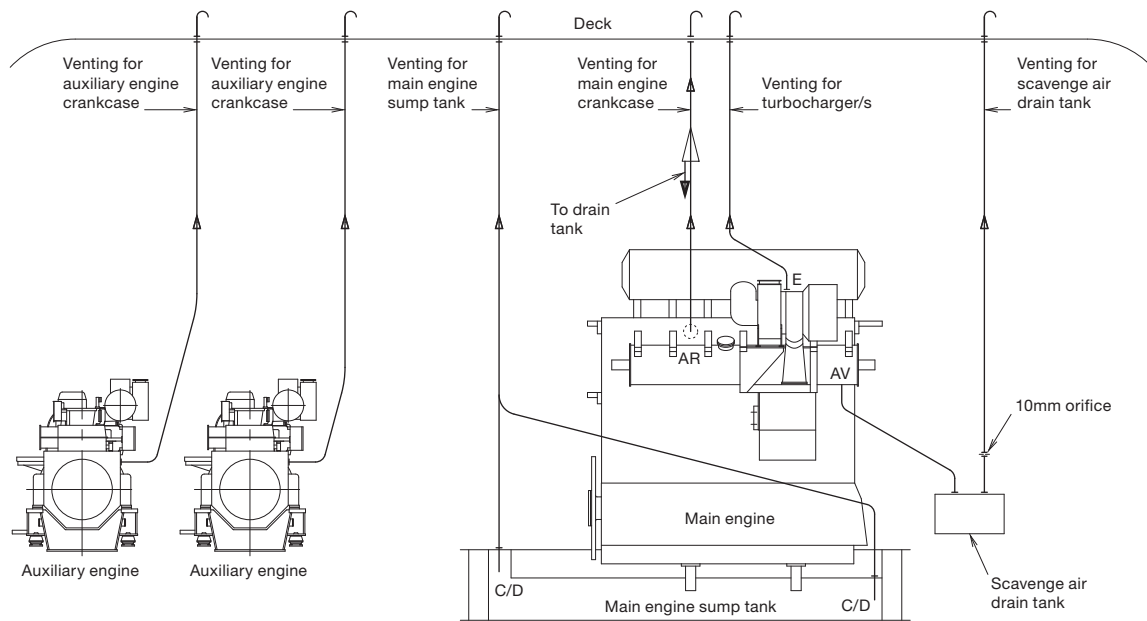
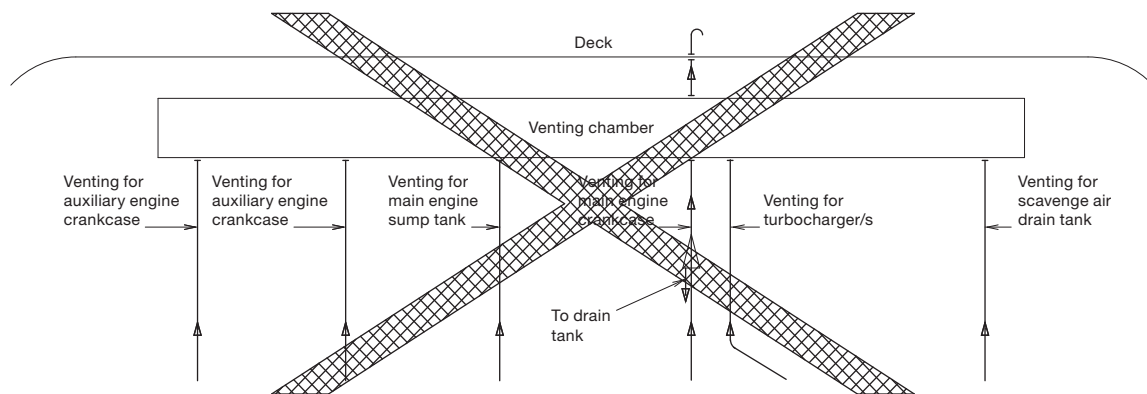

Fig. 8.07.03a: Separate venting of all systems directly to outside air above deck



079 61 00-5.1.1

Fig. 8.07.03b: Venting through a common venting chamber is **not recommended**



### Hydraulic Oil Back-flushing

The special suction arrangement for purifier suction in connection with the ME engine (Integrated system).

The back-flushing oil from the self cleaning 6 µm hydraulic control oil filter unit built onto the engine is contaminated and it is therefore not expedient to lead it directly into the lubricating oil sump tank.

The amount of back-flushed oil is large, and it is considered to be too expensive to discard it. Therefore, we suggest that the lubricating oil sump tank is modified for the ME engines in order not to have this contaminated lubricating hydraulic control oil mixed up in the total amount of lubricating oil. The lubricating oil sump tank is designed with a small 'back-flushing hydraulic control oil drain tank' to which the back-flushed hydraulic control oil is led and from which the lubricating oil purifier can also suck.

This is explained in detail below and the principle is shown in Fig. 8.08.01. Three suggestions for the arrangement of the drain tank in the sump tank are shown in Fig. 8.08.02 illustrates another suggestion for a back-flushing oil drain tank.

The special suction arrangement for the purifier is consisting of two connected tanks (lubricating oil sump tank and back-flushing oil drain tank) and of this reason the oil level will be the same in both tanks, as explained in detail below.

The oil level in the two tanks will be equalizing through the 'branch pipe to back-flushing oil drain tank', see Fig. 8.08.01. As the pipes have the same diameters but a different length, the resistance is larger in the 'branch pipe to back-flushing oil drain tank', and therefore the purifier will suck primarily from the sump tank.

The oil level in the sump tank and the back-flushing oil drain tank will remain to be about equal because the tanks are interconnected at the top.

When hydraulic control oil is back-flushed from the filter, it will give a higher oil level in the back-flushing hydraulic control oil drain tank and the purifier will suck from this tank until the oil level is the same in both tanks. After that, the purifier will suck from the sump tank, as mentioned above.

This special arrangement for purifier suction will ensure that a good cleaning effect on the lubrication oil is obtained.

If found profitable the back-flushed lubricating oil from the main lubricating oil filter (normally a 50 or 40 µm filter) can also be returned into the special back-flushing oil drain tank.

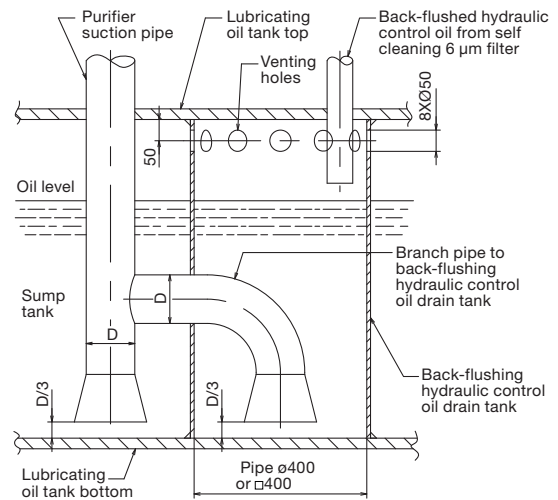

178 52 49-6.2

Fig. 8.08.01: Back-flushing servo oil drain tank

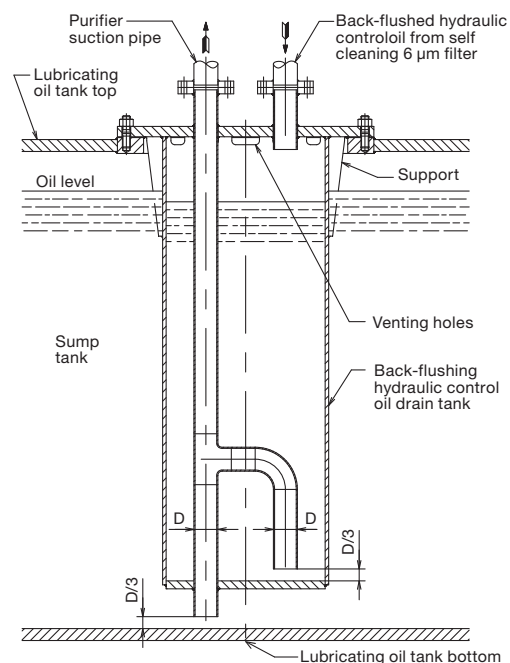

178 52 51-8.2

Fig. 8.08.02: Alternative design for the back-flushing servo oil drain tank



## Separate System for Hydraulic Control Unit

As an option, the engine can be prepared for the use of a separate hydraulic control oil system Fig. 8.09.01.

The separate hydraulic control oil system can be built as a unit, or be built streamlined in the engine room with the various components placed and fastened to the steel structure of the engine room.

The design and the dimensioning of the various components are based on the aim of having a reliable system that is able to supply low-pressure oil to the inlet of the engine-mounted high-pressure hydraulic control oil pumps at a constant pressure, both at engine stand-by and at various engine loads.

### Cleanliness of the hydraulic control oil

The hydraulic control oil must fulfil the same cleanliness level as for our standard integrated lube/cooling/hydraulic-control oil system, i.e. ISO 4406 XX/16/13 equivalent to NAS 1638 Class 7.

Information and recommendations regarding flushing, the specified cleanliness level and how to measure it, and how to use the NAS 1638 oil cleanliness code as an alternative to ISO 4406, are available from MAN Diesel & Turbo.

### Control oil system components

The hydraulic control oil system comprises:

- 1 Hydraulic control oil tank
- 2 Hydraulic control oil pumps (one for stand-by)
- 1 Pressure control valve
- 1 Hydraulic control oil cooler, water-cooled by the low temperature cooling water
- 1 Three-way valve, temperature controlled
- 1 Hydraulic control oil filter, duplex type or automatic self-cleaning type
- 1 Hydraulic control oil fine filter with pump
- 1 Temperature indicator
- 1 Pressure indicator
- 2 Level alarms
- Valves and cocks
- Piping.

### Hydraulic control oil tank

The tank can be made of mild steel plate or be a part of the ship structure.

The tank is to be equipped with flange connections and the items listed below:

- 1 Oil filling pipe
- 1 Outlet pipe for pump suctions
- 1 Return pipe from engine
- 1 Drain pipe
- 1 Vent pipe.

The hydraulic control oil tank is to be placed at least 1 m below the hydraulic oil outlet flange, RZ.

### Hydraulic control oil pump

The pump must be of the displacement type (e.g. gear wheel or screw wheel pump).

The following data is specified in Table 8.09.02:

- Pump capacity
- Pump head
- Delivery pressure
- Working temperature
- Oil viscosity range.

### Pressure control valve

The valve is to be of the self-operating flow controlling type, which bases the flow on the pre-defined pressure set point. The valve must be able to react quickly from the fully-closed to the fully-open position ( $t_{\max} = 4$  sec), and the capacity must be the same as for the hydraulic control oil low-pressure pumps. The set point of the valve has to be within the adjustable range specified in a separate drawing.

The following data is specified in Table 8.09.02:

- Flow rate
- Adjustable differential pressure range across the valve
- Oil viscosity range.



### Hydraulic control oil cooler

The cooler must be of the plate heat exchanger or shell and tube type.

The following data is specified in Table 8.09.02:

- Heat dissipation
- Oil flow rate
- Oil outlet temperature
- Maximum oil pressure drop across the cooler
- Cooling water flow rate
- Water inlet temperature
- Maximum water pressure drop across the cooler.

### Temperature controlled three-way valve

The valve must act as a control valve, with an external sensor.

The following data is specified in Table 8.09.02:

- Capacity
- Adjustable temperature range
- Maximum pressure drop across the valve.

### Hydraulic control oil filter

The filter is to be of the duplex full flow type with manual change over and manual cleaning or of the automatic self cleaning type.

A differential pressure gauge is fitted onto the filter.

The following data is specified in Table 8.09.02:

- Filter capacity
- Maximum pressure drop across the filter
- Filter mesh size (absolute)
- Oil viscosity
- Design temperature.

### Off-line hydraulic control oil fine filter / purifier

Shown in Fig. 8.09.01, the off-line fine filter unit or purifier must be able to treat 15-20% of the total oil volume per hour.

The fine filter is an off-line filter and removes metallic and non-metallic particles larger than 0,8 µm as well as water and oxidation **residues**. The filter has a pertaining pump and is to be fitted on the top of the hydraulic control oil tank.

A suitable fine filter unit is:

Make: CJC, C.C. Jensen A/S, Svendborg, Denmark - [www.cjc.dk](http://www.cjc.dk).

For oil volume <10,000 litres:

HDU 27/-MZ-Z with a pump flow of 15-20% of the total oil volume per hour.

For oil volume >10,000 litres:

HDU 27/-GP-DZ with a pump flow of 15-20% of the total oil volume per hour.

### Temperature indicator

The temperature indicator is to be of the liquid straight type.

### Pressure indicator

The pressure indicator is to be of the dial type.

### Level alarm

The hydraulic control oil tank has to have level alarms for high and low oil level.

### Piping

The pipes can be made of mild steel.

The design oil pressure is to be 10 bar.

The return pipes are to be placed vertical or laid with a downwards inclination of minimum 15°.

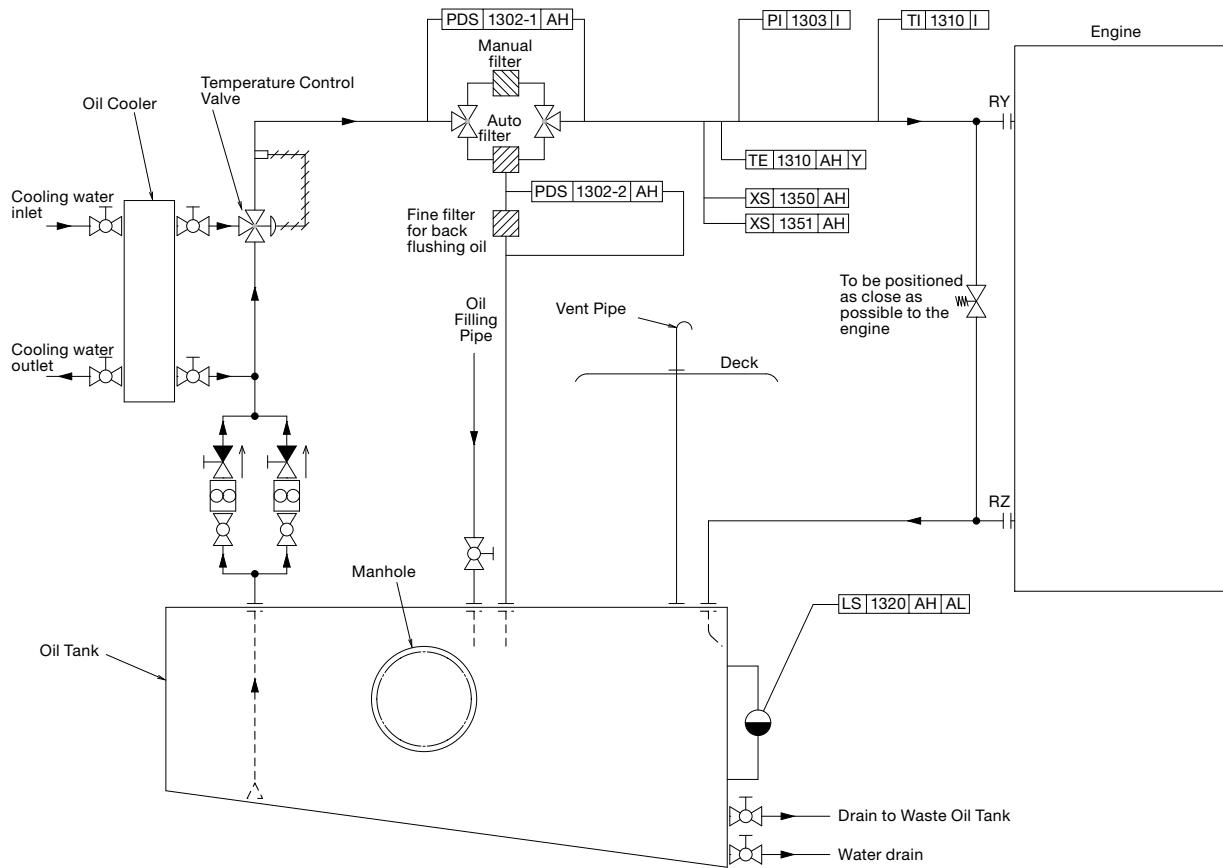

078 83 82-6.4.0

Fig. 8.09.01: Hydraulic control oil system, manual filter





**MAN B&W**

---

# Cylinder Lubrication

9

---

**MAN Diesel**



### Cylinder Lubricating Oil System

The cost of the cylinder lubricating oil is one of the largest contributions to total operating costs, next to the fuel oil cost. Another aspect is that the lubrication rate has a great influence on the cylinder condition, and thus on the overhauling schedules and maintenance costs.

It is therefore of the utmost importance that the cylinder lubricating oil system as well as its operation is optimised.

#### Cylinder oils

In short, MAN Diesel and Turbo recommends the use of cylinder oils with the following main properties:

- SAE 50 viscosity grade
- high detergency
- BN 100 for high-sulphur fuel
- BN 40 for low-sulphur fuel.

A BN 100 cylinder oil is to be used as the default choice of oil and it may be used on all fuel types. However, in case of the engine running on fuel with sulphur content lower than 1.5% for more than 2 weeks, we recommend to change to a lower BN cylinder oil such as a BN 40.

#### Two-tank cylinder oil supply system

Fig. 9.01.01 shows a cylinder oil supply system with separate tanks for cylinder oils with high and low BN.

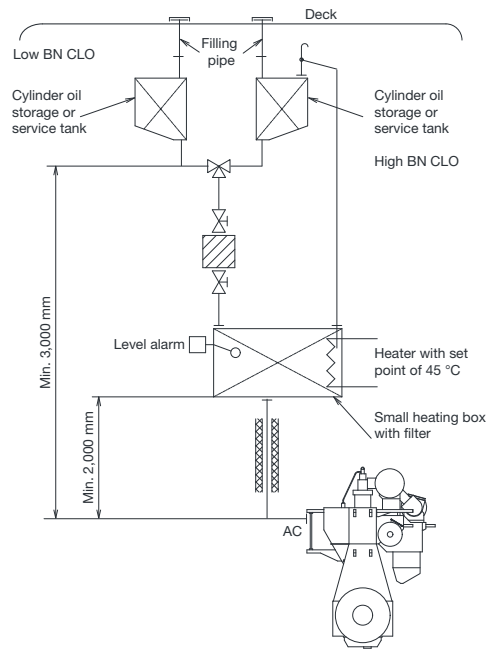

The letters refer to list of 'Counterflanges'

178 52 37-6.3

Fig. 9.01.01: Cylinder lubricating oil system

#### Cylinder oil feed rate (dosage)

Adjustment of the cylinder oil dosage to the sulphur content in the fuel being burnt is further explained in Section 9.02.

Further information about cylinder lubrication on different fuel types is available in our publication:

#### Operation on Low-Sulphur Fuels

The publication is available at [www.marine.man.eu](http://www.marine.man.eu) → 'Two-Stroke' → 'Technical Papers'.

**List of cylinder oils**

The major international cylinder oil brands listed below have been tested in service with acceptable results. Some of the oils have also given satisfactory service results during long-term operation on MAN B&W engines running on heavy fuel oil (HFO).

Company	Cylinder oil name, SAE 50	BN level
Aegean	Alfacylo 540 LS	40
	Alfacylo 100 HS	100
BP	CL-DX 405	40
	Energol CL 100 ACC	100
Castrol	Cyltech 40SX	40
	Cyltech CL 100 ACC	100
Chevron	Taro Special HT LS 40	40
	Taro Special HT 100	100
ExxonMobil	Mobilgard L540	40
	Mobilgard 5100	100
Gulf Oil Marine	GulfSea Cylcare DCA 5040H	40
	GulfSea Cylcare 50100	100
JX Nippon Oil & Energy	Marine C405	40
	MC-1005-8 ( <i>internal code</i> )	100
Lukoil	Navigo 40 MCL	40
	Navigo 100 MCL	100
Shell	Alexia S6	100
Sinopec	Marine Cylinder Oil 5040	40
Total	Talusia LS 40	40
	Talusia Universal 100	100

Oils from other companies can be equally suitable. Further information can be obtained from the engine builder or MAN Diesel & Turbo, Copenhagen.



## MAN B&W Alpha Cylinder Lubrication System

The MAN B&W Alpha cylinder lubrication system, see Figs. 9.02.02a and 9.02.02b, is designed to supply cylinder oil intermittently, e.g. every four engine revolutions with electronically controlled timing and dosage at a defined position.

The cylinder lubricating oil is pumped from the cylinder oil storage tank to the service tank, the size of which depends on the owner's and the yard's requirements, - it is normally dimensioned for minimum two days' cylinder lubricating oil consumption.

Cylinder lubricating oil is fed to the Alpha cylinder lubrication system by gravity from the service tank.

The storage tank and the service tank may alternatively be one and the same tank.

The oil fed to the injectors is pressurised by means of the Alpha Lubricator which is placed on the HCU and equipped with small multi-piston pumps.

The oil pipes fitted on the engine is shown in Fig. 9.02.04.

The whole system is controlled by the Cylinder Control Unit (CCU) which controls the injection frequency on the basis of the engine-speed signal given by the tacho signal and the fuel index.

Prior to start-up, the cylinders can be pre-lubricated and, during the running-in period, the operator can choose to increase the lubricating oil feed rate to a max. setting of 200%.

The MAN B&W Alpha Cylinder Lubricator is preferably to be controlled in accordance with the Alpha ACC (Adaptive Cylinder oil Control) feed rate system.

The yard supply should be according to the items shown in Fig. 9.02.02a within the broken line. With regard to the filter and the small box, please see Fig. 9.02.05.



### Alpha Adaptive Cylinder Oil Control (Alpha ACC)

It is a well-known fact that the actual need for cylinder oil quantity varies with the operational conditions such as load and fuel oil quality. Consequently, in order to perform the optimal lubrication – cost-effectively as well as technically – the cylinder lubricating oil dosage should follow such operational variations accordingly.

The Alpha lubricating system offers the possibility of saving a considerable amount of cylinder lubricating oil per year and, at the same time, to obtain a safer and more predictable cylinder condition.

Alpha ACC (Adaptive Cylinder-oil Control) is the lubrication mode for MAN B&W two-stroke engines, i.e. lube oil dosing proportional to the engine load and proportional to the sulphur content in the fuel oil being burnt.

#### Working principle

The feed rate control should be adjusted in relation to the actual fuel quality and amount being burnt at any given time.

The following criteria determine the control:

- The cylinder oil dosage shall be proportional to the sulphur percentage in the fuel
- The cylinder oil dosage shall be proportional to the engine load (i.e. the amount of fuel entering the cylinders)
- The actual feed rate is dependent of the operating pattern and determined based on engine wear and cylinder condition.

The implementation of the above criteria will lead to an optimal cylinder oil dosage.

#### Specific minimum dosage with Alpha ACC

The recommendations are valid for all plants, whether controllable pitch or fixed pitch propellers are used. The specific minimum dosage at lower-sulphur fuels is set at 0.6 g/kWh.

After a running-in period of 500 hours, the feed rate sulphur proportional factor is 0.20 - 0.34 g/kWh × S%. The actual ACC factor will be based on cylinder condition, and preferably a cylinder oil feed rate sweep test should be applied.

Examples of average cylinder oil consumption based on calculations of the average worldwide sulphur content used on MAN B&W two-stroke engines are shown in Fig. 9.02.01a and b.

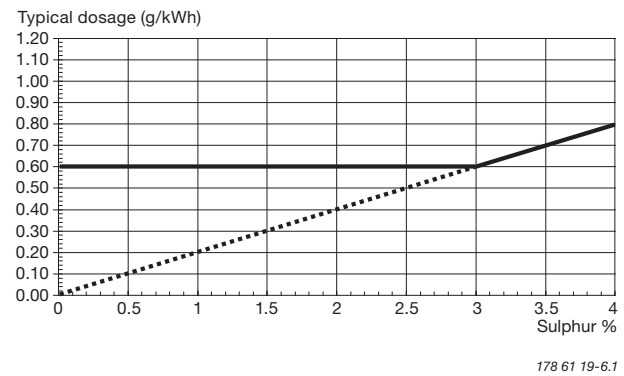

Fig. 9.02.01a: ACC = 0.20 g/kWh × S% and BN100 cylinder oil – average consumption less than 0.65 g/kWh

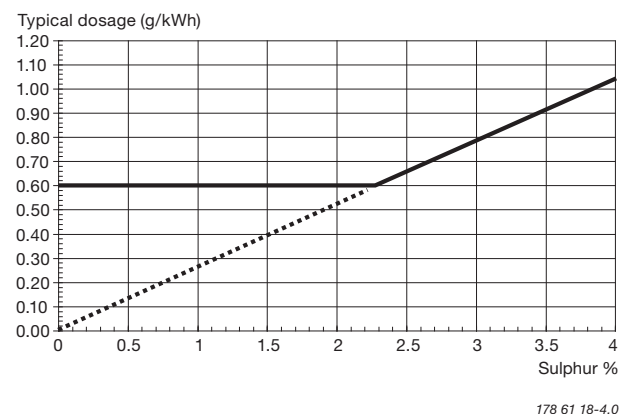

Fig. 9.02.01b: ACC = 0.26 g/kWh × S% and BN100 cylinder oil – average consumption less than 0.7 g/kWh

Further information on cylinder oil as a function of fuel oil sulphur content, alkalinity of lubricating oil and operating pattern as well as assessing the engine wear and cylinder condition is available from MAN Diesel & Turbo, Copenhagen.



### Cylinder Oil Pipe Heating

In case of low engine room temperature, it can be difficult to keep the cylinder oil temperature at 45 °C at the MAN B&W Alpha Lubricator, mounted on the hydraulic cylinder.

Therefore the cylinder oil pipe from the small tank, see Figs. 9.02.02a and 9.02.02b, in the vessel and of the main cylinder oil pipe on the engine is insulated and electrically heated.

The engine builder is to make the insulation and heating on the main cylinder oil pipe on the engine. Moreover, the engine builder is to mount the junction box and the thermostat on the engine. See Fig. 9.02.03.

The ship yard is to make the insulation of the cylinder oil pipe in the engine room. The heating cable supplied by the engine builder is to be mounted from the small tank to the junction box on the engine. See Figs. 9.02.02a and 9.02.02b.

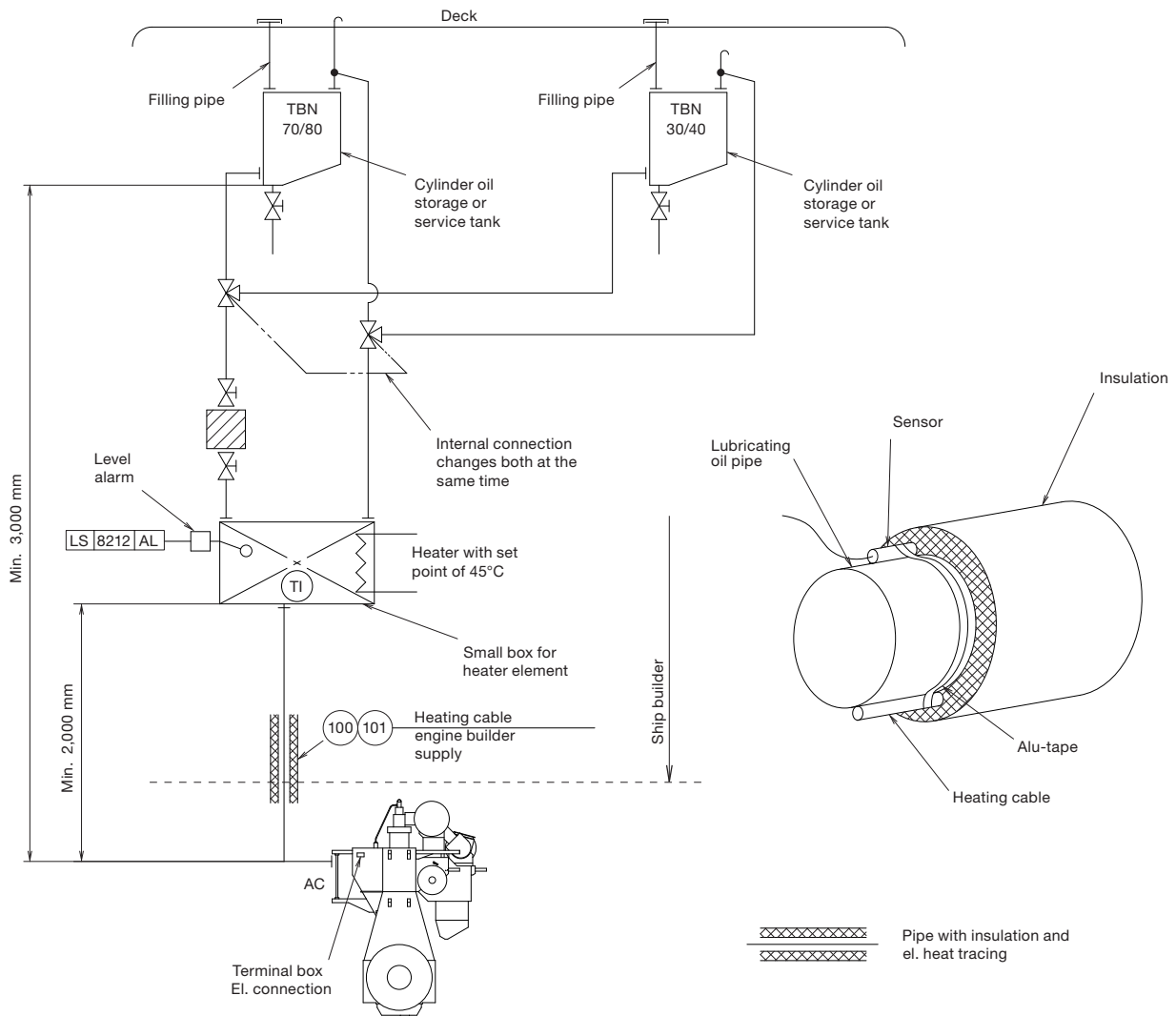

0079 33 17-1.0.1

Fig. 9.02.02a: Cylinder lubricating oil system with dual service tanks for two different TBN cylinder oils

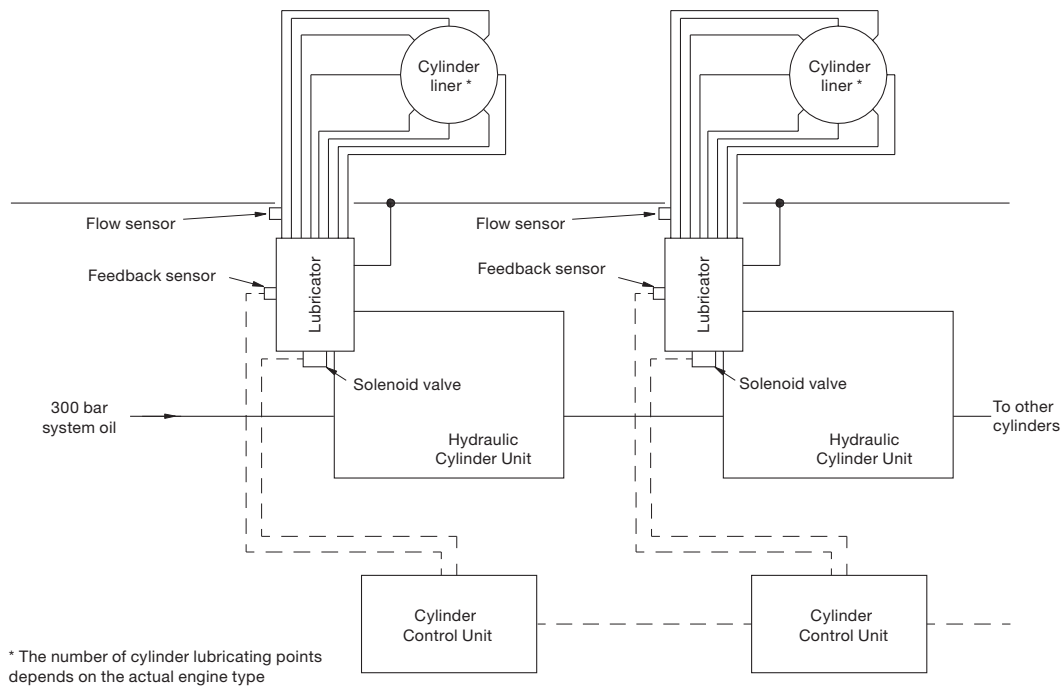

178 49 83-4.8b

Fig. 9.02.02b: Cylinder lubricating oil system. Example from 80/70/65ME-C engines

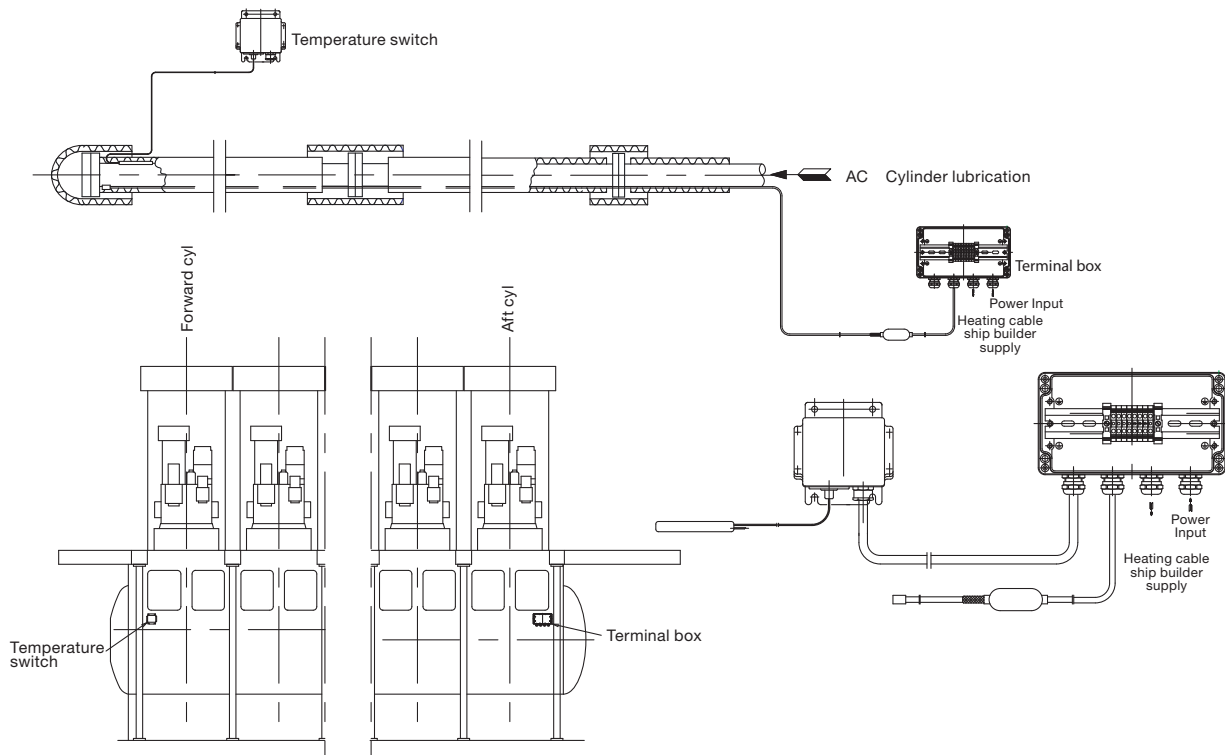

178 53 71-6.0

Fig. 9.02.03: Electric heating of cylinder oil pipes

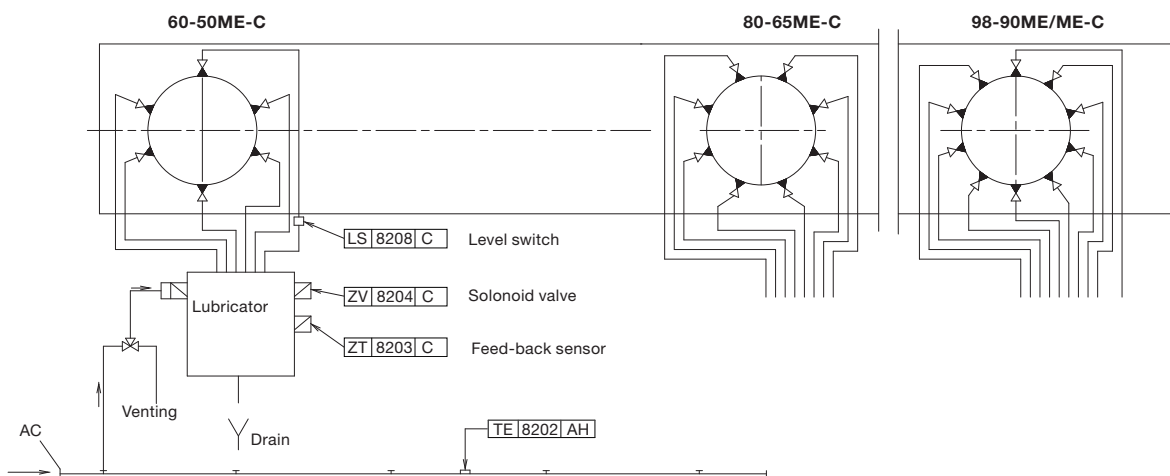

The letters refer to list of 'Counterflanges'  
 The item No refer to 'Guidance Values Automation'

121 50 90-1.6.1

Fig. 9.02.04: Cylinder lubricating oil pipes



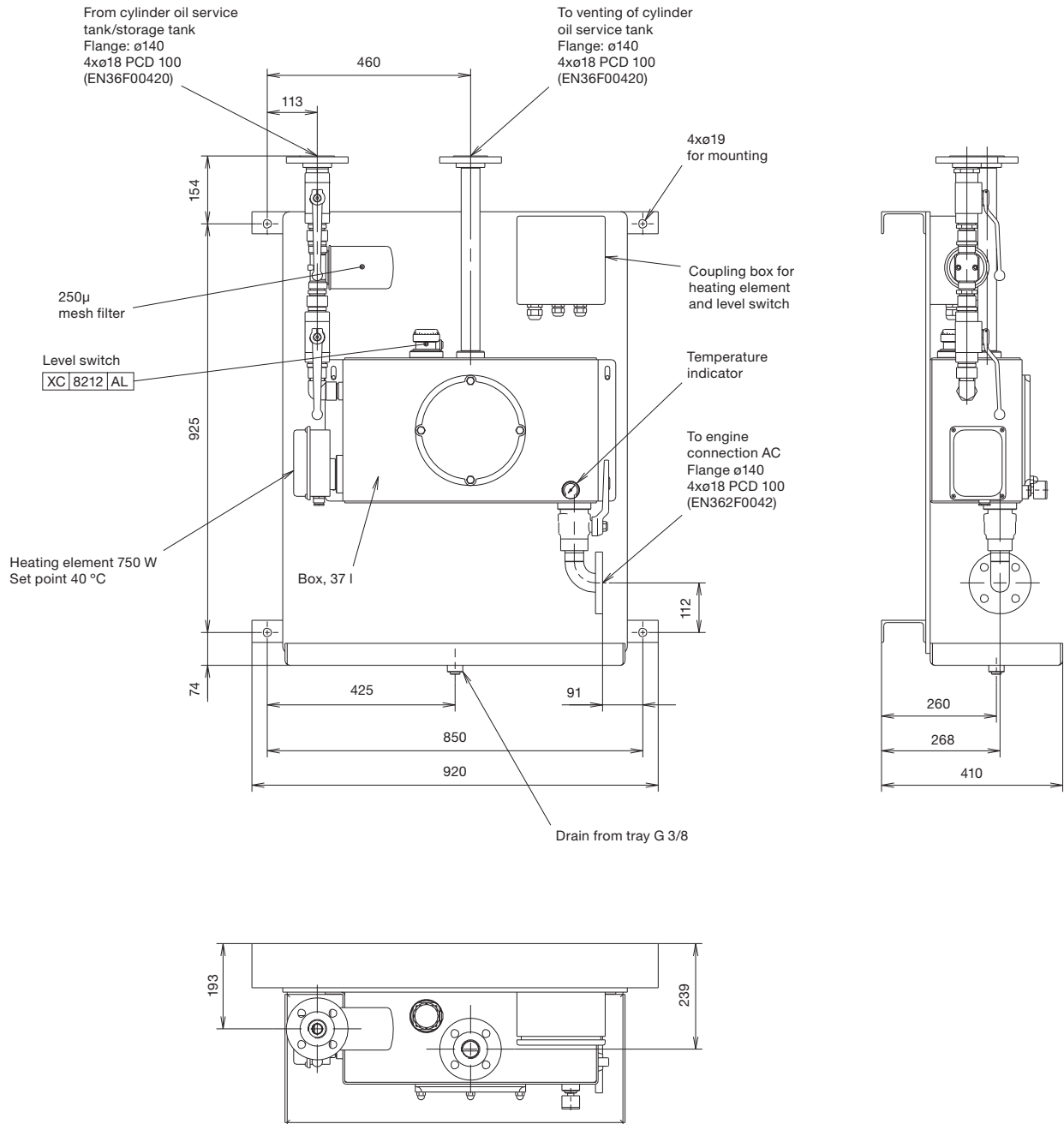

178 52 75-8.1

Fig. 9.02.05: Suggestion for small heating box with filter



**MAN B&W**

---

---

# Piston Rod Stuffing Box Drain Oil

# 10

---

---

**MAN Diesel**



### Stuffing Box Drain Oil System

For engines running on heavy fuel, it is important that the oil drained from the piston rod stuffing boxes is not led directly into the system oil, as the oil drained from the stuffing box is mixed with sludge from the scavenge air space.

The performance of the piston rod stuffing box on the engines has proved to be very efficient, primarily because the hardened piston rod allows a higher scraper ring pressure.

The amount of drain oil from the stuffing boxes is about 5 - 10 litres/24 hours per cylinder during normal service. In the running-in period, it can be higher.

The relatively small amount of drain oil is led to the general oily waste drain tank or is burnt in the incinerator, Fig. 10.01.01. (Yard's supply).

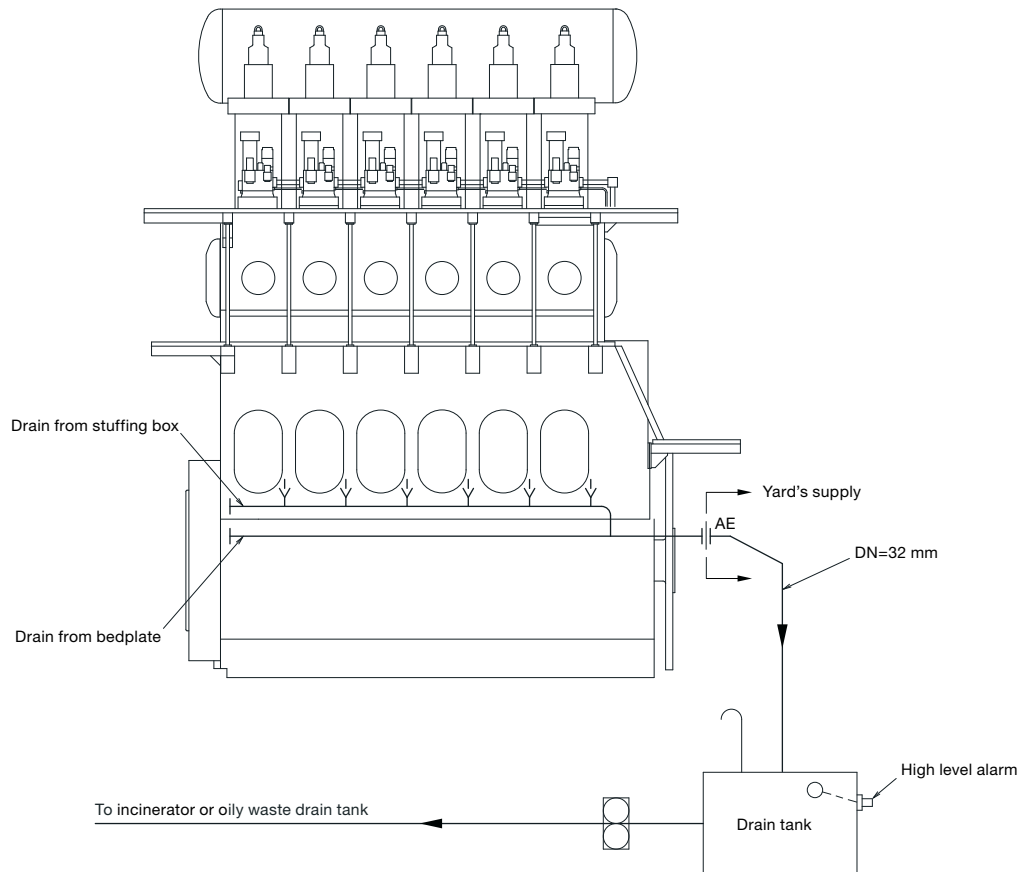

079 32 26-0.1.1

Fig. 10.01.01: Stuffing box drain oil system



**MAN B&W**

---

# Central Cooling Water System

11

---

**MAN Diesel**



## Central Cooling

The water cooling can be arranged in several configurations, the most common system choice being a central cooling water system.

### Advantages of the central cooling system:

- Only one heat exchanger cooled by seawater, and thus, only one exchanger to be overhauled
- All other heat exchangers are freshwater cooled and can, therefore, be made of a less expensive material
- Few non-corrosive pipes to be installed
- Reduced maintenance of coolers and components
- Increased heat utilisation.

### Disadvantages of the central cooling system:

- Three sets of cooling water pumps (seawater, central water and jacket water).
- Higher first cost.

For information on the alternative Seawater Cooling System, see Chapter 12.

An arrangement common for the main engine and MAN Diesel & Turbo auxiliary engines is available on request.

For further information about common cooling water system for main engines and auxiliary engines please refer to our publication:

*Uni-concept Auxiliary Systems for Two-Stroke Main Engines and Four-Stroke Auxiliary Engines*

The publication is available at [www.marine.man.eu](http://www.marine.man.eu)  
→ 'Two-Stroke' → 'Technical Papers'.



### Central Cooling Water System

The central cooling water system is characterised by having only one heat exchanger cooled by seawater, and by the other coolers, including the jacket water cooler, being cooled by central cooling water.

In order to prevent too high a scavenge air temperature, the cooling water design temperature in the central cooling water system is normally 36 °C, corresponding to a maximum seawater temperature of 32 °C.

Our recommendation of keeping the cooling water inlet temperature to the main engine scavenge

air cooler as low as possible also applies to the central cooling system. This means that the temperature control valve in the central cooling water circuit is to be set to minimum 10 °C, whereby the temperature follows the outboard seawater temperature when central cooling water temperature exceeds 10 °C.

For external pipe connections, we prescribe the following maximum water velocities:

- Jacket water ..... 3.0 m/s
- Central cooling water ..... 3.0 m/s
- Seawater ..... 3.0 m/s

Regarding the lubricating oil coolers, this valve should be adjusted so that the inlet temperature of the cooling water is not below 10 °C

Air pockets, if any, in the pipe line between the pumps, must be vented to the expansion tank

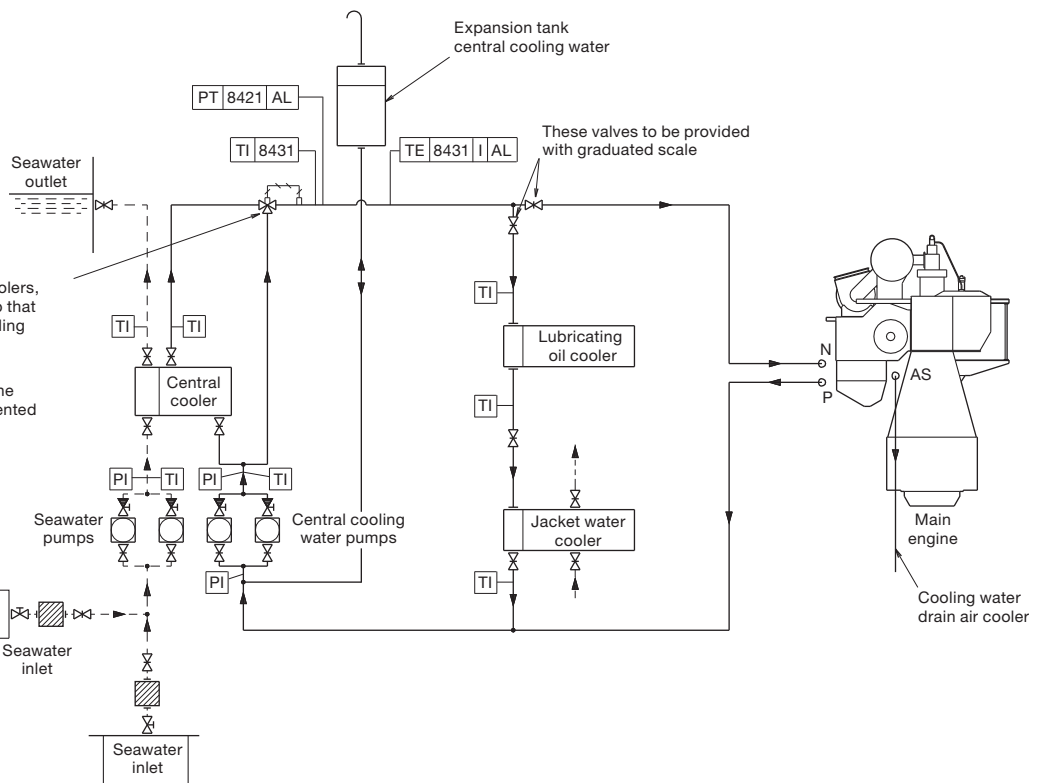

— Jacket cooling water  
 - - - Sea water  
 - - - - Fuel oil

The letters refer to list of 'Counterflanges', Fig. 5.10.01  
The item No. refer to 'Guidance values automation'

178 52 77-1.1

Fig. 11.02.01: Central cooling water system



### Components for Central Cooling Water System

#### Seawater cooling pumps

The pumps are to be of the centrifugal type.

- Seawater flow..... see 'List of Capacities'
- Pump head .....2.5 bar
- Test pressure.....according to class rules
- Working temperature, normal .....0-32 °C
- Working temperature ..... maximum 50 °C

The flow capacity must be within a range from 100 to 110% of the capacity stated.

The differential pressure of the pumps is to be determined on the basis of the total actual pressure drop across the cooling water system.

#### Central cooler

The cooler is to be of the shell and tube or plate heat exchanger type, made of seawater resistant material.

- Heat dissipation..... see 'List of Capacities'
- Central cooling water flow ..... see 'List of Capacities'
- Central cooling water temperature, outlet..... 36 °C
- Pressure drop on central cooling side ....max. 0.2 bar
- Seawater flow..... see 'List of Capacities'
- Seawater temperature, inlet ..... 32 °C
- Pressure drop on seawater side..... maximum 0.2 bar

The pressure drop may be larger, depending on the actual cooler design.

The heat dissipation and the seawater flow figures are based on MCR output at tropical conditions, i.e. a seawater temperature of 32 °C and an ambient air temperature of 45 °C.

Overload running at tropical conditions will slightly increase the temperature level in the cooling system, and will also slightly influence the engine performance.

#### Central cooling water pumps

The pumps are to be of the centrifugal type.

- Central cooling water flow... see 'List of Capacities'
- Pump head .....2.5 bar
- Delivery pressure .....depends on location of expansion tank
- Test pressure.....according to class rules
- Working temperature ..... 80 °C
- Design temperature..... 100 °C

The flow capacity must be within a range from 100 to 110% of the capacity stated.

The 'List of Capacities' covers the main engine only. The differential pressure provided by the pumps is to be determined on the basis of the total actual pressure drop across the cooling water system.

#### Central cooling water thermostatic valve

The low temperature cooling system is to be equipped with a three-way valve, mounted as a mixing valve, which by-passes all or part of the fresh water around the central cooler.

The sensor is to be located at the outlet pipe from the thermostatic valve and is set so as to keep a temperature level of minimum 10 °C.



**Jacket water system**

Due to the central cooler the cooling water inlet temperature is about 4 °C higher for for this system compared to the seawater cooling system. The input data are therefore different for the scavenge air cooler, the lube oil cooler and the jacket water cooler.

The heat dissipation and the central cooling water flow figures are based on an MCR output at tropical conditions, i.e. a maximum seawater temperature of 32 °C and an ambient air temperature of 45 °C.

**Jacket water cooling pump**

The pumps are to be of the centrifugal type.  
Jacket water flow ..... see 'List of Capacities'  
Pump head .....3.0 bar  
Delivery pressure .....depends on location of expansion tank  
Test pressure.....according to class rules  
Working temperature ..... 80 °C  
Design temperature..... 100 °C

The flow capacity must be within a range from 100 to 110% of the capacity stated.

The stated of capacities cover the main engine only. The pump head of the pumps is to be determined on the basis of the total actual pressure drop across the cooling water system.

**Scavenge air cooler**

The scavenge air cooler is an integrated part of the main engine.

Heat dissipation ..... see 'List of Capacities'  
Central cooling water flow ..... see 'List of Capacities'  
Central cooling temperature, inlet ..... 36 °C  
Pressure drop on FW-LT water side.... approx. 0.5 bar

**Lubricating oil cooler**

See Chapter 8 'Lubricating Oil'.

**Cooling water pipes**

Diagrams of cooling water pipes are shown in Figs. 12.03.01.

**Jacket water cooler**

The cooler is to be of the shell and tube or plate heat exchanger type.

Heat dissipation ..... see 'List of Capacities'  
Jacket water flow ..... see 'List of Capacities'  
Jacket water temperature, inlet..... 80 °C  
Pressure drop on jacket water side ....max. 0.2 bar  
Central cooling water flow... see 'List of Capacities'  
Central cooling water temperature, inlet .....approx. 42 °C  
Pressure drop on Central cooling water side.....max. 0.2 bar

The other data for the jacket cooling water system can be found in Chapter 12.

For further information about a common cooling water system for main engines and MAN Diesel & Turbo auxiliary engines, please refer to our publication:

*Uni-concept Auxiliary Systems for Two-Stroke Main Engines and Four-Stroke Auxiliary Engines*

The publication is available at [www.marine.man.eu](http://www.marine.man.eu) → 'Two-Stroke' → 'Technical Papers'.





**MAN B&W**

---

# Seawater Cooling System

# 12

---

**MAN Diesel**



## Seawater Systems

The water cooling can be arranged in several configurations, the most simple system choices being seawater and central cooling water system:

- A **seawater cooling system** and a jacket cooling water system
- The advantages of the seawater cooling system are mainly related to first cost, viz:
- Only two sets of cooling water pumps (seawater and jacket water)
- Simple installation with few piping systems.

Whereas the disadvantages are:

- Seawater to all coolers and thereby higher maintenance cost
- Expensive seawater piping of non-corrosive materials such as galvanised steel pipes or Cu-Ni pipes.



### Seawater Cooling System

The seawater cooling system is used for cooling, the main engine lubricating oil cooler, the jacket water cooler and the scavenge air cooler, see Fig. 12.02.01.

The lubricating oil cooler for a PTO step-up gear should be connected in parallel with the other coolers. The capacity of the seawater pump is based on the outlet temperature of the seawater being maximum 50 °C after passing through the coolers – with an inlet temperature of maximum 32 °C (tropical conditions), i.e. a maximum temperature increase of 18 °C.

The valves located in the system fitted to adjust the distribution of cooling water flow are to be provided with graduated scales.

The inter-related positioning of the coolers in the system serves to achieve:

- The lowest possible cooling water inlet temperature to the lubricating oil cooler in order to obtain the cheapest cooler. On the other hand, in order to prevent the lubricating oil from stiffening in cold services, the inlet cooling water temperature should not be lower than 10 °C
- The lowest possible cooling water inlet temperature to the scavenge air cooler, in order to keep the fuel oil consumption as low as possible.

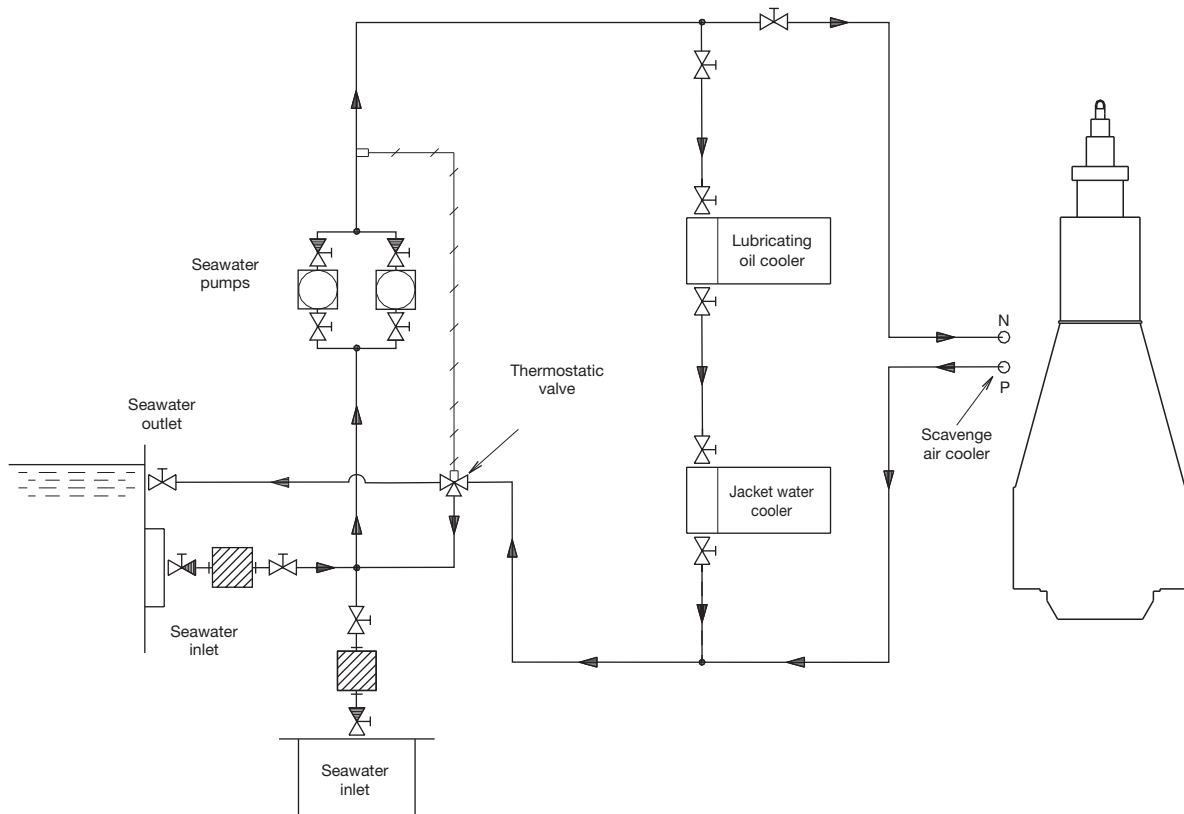

198 98 13-2.5

The letters refer to list of 'Counterflanges'

Fig. 12.02.01: Seawater cooling system



### Cooling Water Pipes

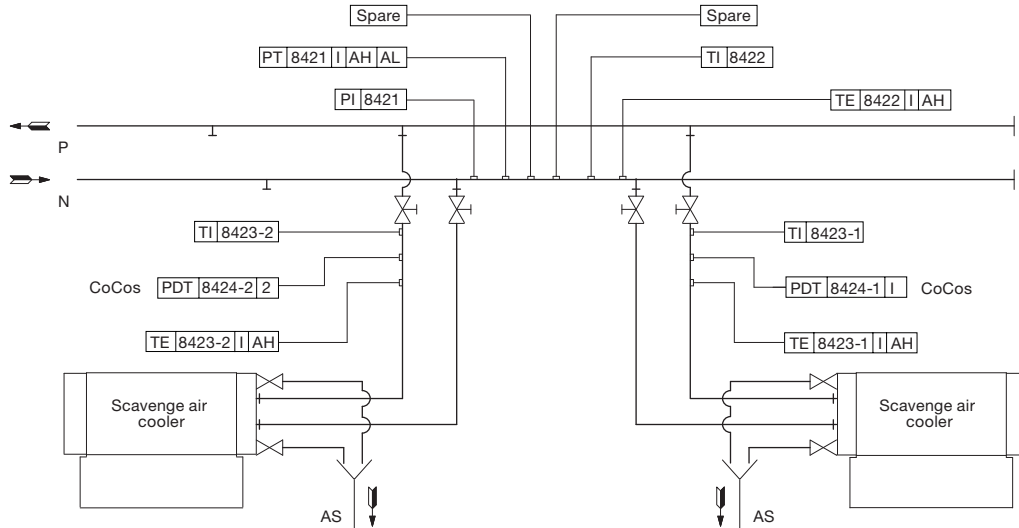

121 14 99-1.7.0

The letters refer to list of 'Counterflanges'. The item No. refer to 'Guidance Values Automation'

Fig. 12.03.01a: Cooling water pipes for engines with two or more turbochargers

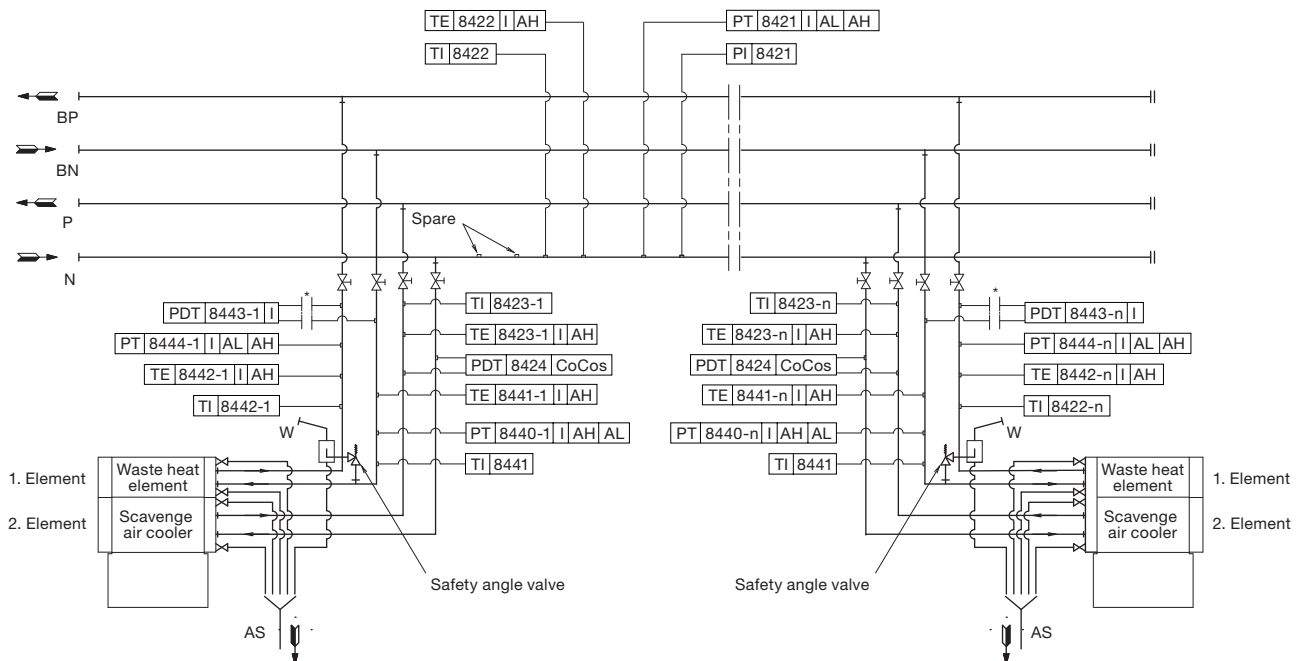

521 21 78-2.3.0

The letters refer to list of 'Counterflanges'. The item No. refer to 'Guidance Values Automation'

- \* Calculated valve from PT8440/844X if possible
- n Refer to number of air coolers

Fig. 12.03.01b: Cooling water cooling pipes with waste heat recovery for engines with two or more turbochargers



## Components for Seawater Cooling System

### Seawater cooling pump

The pumps are to be of the centrifugal type.

Seawater flow ..... see 'List of Capacities'  
Pump head ..... 2.5 bar  
Test pressure ..... according to class rule  
Working temperature ..... maximum 50 °C

The flow capacity must be within a range from 100 to 110% of the capacity stated.

### Lubricating oil cooler

See Chapter 8 'Lubricating Oil'.

### Jacket water cooler

The cooler is to be of the shell and tube or plate heat exchanger type, made of seawater resistant material.

Heat dissipation ..... see 'List of Capacities'  
Jacket water flow ..... see 'List of Capacities'  
Jacket water temperature, inlet ..... 80 °C  
Pressure drop  
on jacket water side ..... maximum 0.2 bar  
Seawater flow ..... see 'List of Capacities'  
Seawater temperature, inlet ..... 38 °C  
Pressure drop on  
seawater side ..... maximum 0.2 bar

The heat dissipation and the seawater flow are based on an MCR output at tropical conditions, i.e. seawater temperature of 32 °C and an ambient air temperature of 45 °C.

### Scavenge air cooler

The scavenge air cooler is an integrated part of the main engine.

Heat dissipation ..... see 'List of Capacities'  
Seawater flow ..... see 'List of Capacities'  
Seawater temperature,  
for seawater cooling inlet, max. .... 32 °C  
Pressure drop on  
cooling water side ..... between 0.1 and 0.5 bar

The heat dissipation and the seawater flow are based on an MCR output at tropical conditions, i.e. seawater temperature of 32 °C and an ambient air temperature of 45 °C.

### Seawater thermostatic valve

The temperature control valve is a three-way valve which can recirculate all or part of the seawater to the pump's suction side. The sensor is to be located at the seawater inlet to the lubricating oil cooler, and the temperature level must be a minimum of +10 °C.

Seawater flow ..... see 'List of Capacities'  
Temperature range,  
adjustable within ..... +5 to +32 °C

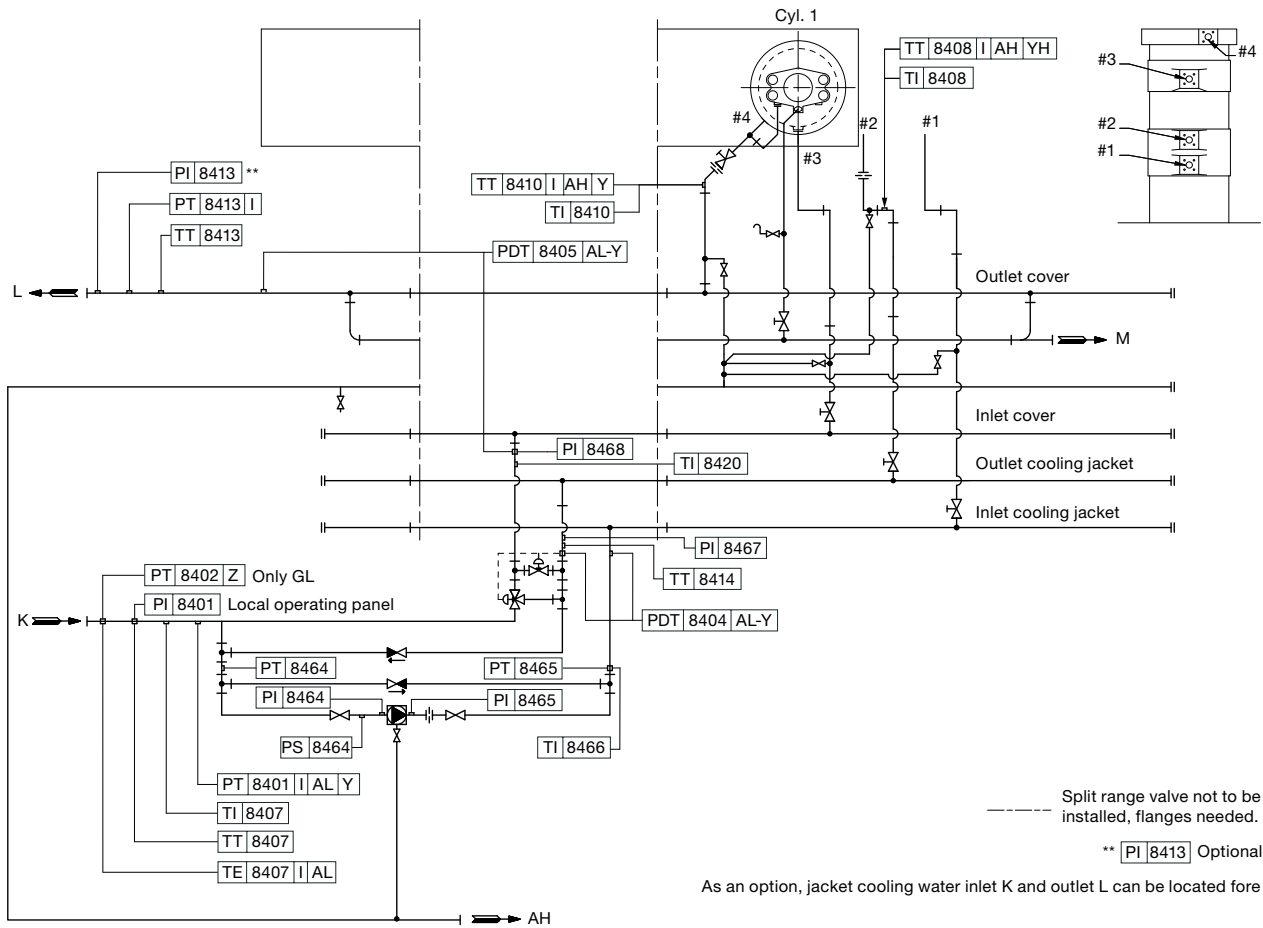

----- Split range valve not to be installed, flanges needed.  
 \*\* PI 8413 Optional  
 As an option, jacket cooling water inlet K and outlet L can be located fore

561 79 40-6.0.0

The letters refer to list of 'Counterflanges'  
 The item No. refer to 'Guidance values automation'

Fig. 12.06.01b: Jacket cooling water pipes





Deaerating tank

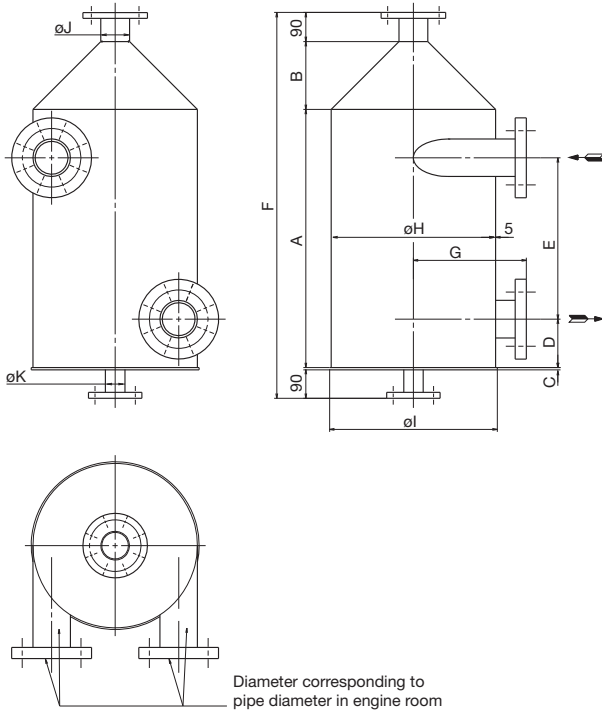

178 06 27-9.2

Fig. 12.07.01: Deaerating tank, option: 4 46 640

Deaerating tank dimensions		
Tank size	0.16 m <sup>3</sup>	0.70 m <sup>3</sup>
Max. jacket water capacity	300 m <sup>3</sup> /h	700 m <sup>3</sup> /h
Dimensions in mm		
Max. nominal diameter	200	300
A	800	1,200
B	210	340
C	5	8
D	150	200
E	500	800
F	1,195	1,728
G	350	550
øH	500	800
øI	520	820
øJ	ND 80	ND 100
øK	ND 50	ND 80

ND: Nominal diameter

Working pressure is according to actual piping arrangement.

In order not to impede the rotation of water, the pipe connection must end flush with the tank, so that no internal edges are protruding.

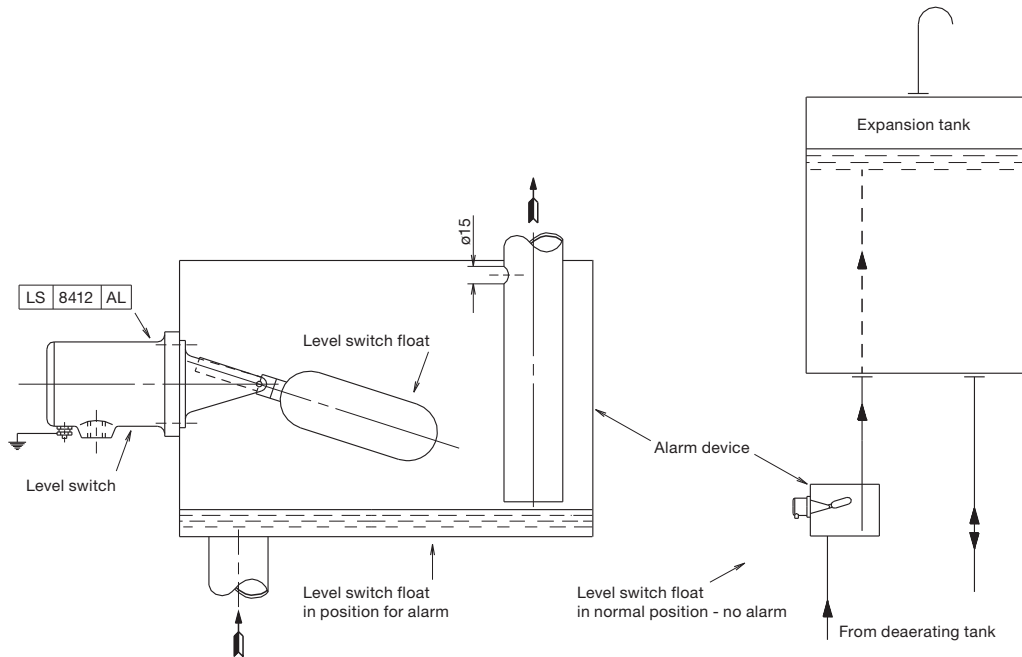

198 97 09-1.1

Fig. 12.07.02: Deaerating tank, alarm device, option: 4 46 645





### Temperature at Start of Engine

In order to protect the engine, some minimum temperature restrictions have to be considered before starting the engine and, in order to avoid corrosive attacks on the cylinder liners during starting.

#### Normal start of engine, fixed pitch propeller

Normally, a minimum engine jacket water temperature of 50 °C is recommended before the engine may be started and run up gradually from 80% to 90% of specified MCR speed (SMCR rpm) during 30 minutes.

For running up between 90% and 100% of SMCR rpm, it is recommended that the speed be increased slowly over a period of 60 minutes.

#### Start of cold engine, fixed pitch propeller

In exceptional circumstances where it is not possible to comply with the above-mentioned recommendation, a minimum of 20 °C can be accepted before the engine is started and run up slowly to 80% of SMCR rpm.

Before exceeding 80% SMCR rpm, a minimum jacket water temperature of 50 °C should be obtained before the above described normal start load-up procedure may be continued.

#### Jacket water warming-up time

The time period required for increasing the jacket water temperature from 20 °C to 50 °C will depend on the amount of water in the jacket cooling water system, and the engine load.

**Note:**

*The above considerations for start of cold engine are based on the assumption that the engine has already been well run-in.*

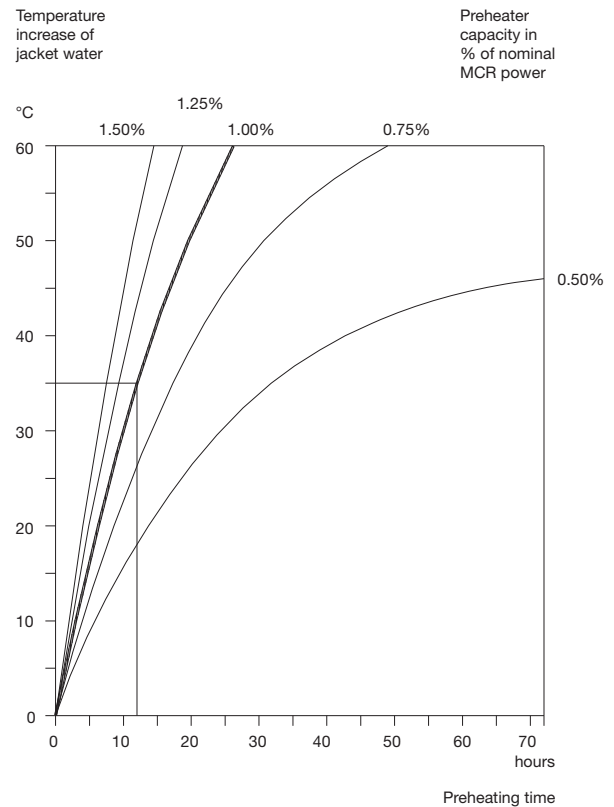

178 16 63-1.1

Fig. 12.08.01: Jacket water preheater, example

### Preheating of diesel engine

#### Preheating during standstill periods

During short stays in port (i.e. less than 4-5 days), it is recommended that the engine is kept preheated, the purpose being to prevent temperature variation in the engine structure and corresponding variation in thermal expansions and possible leakages.

The jacket cooling water outlet temperature should be kept as high as possible and should – before starting up – be increased to at least 50 °C, either by means of cooling water from the auxiliary engines, or by means of a built-in preheater in the jacket cooling water system, or a combination.



**MAN B&W**

---

# Starting and Control Air

13

---

**MAN Diesel**



### Starting and Control Air Systems

The starting air of 30 bar is supplied by the starting air compressors to the starting air receivers and from these to the main engine inlet 'A'.

Through a reduction station, filtered compressed air at 7 bar is supplied to the control air for exhaust valve air springs, through engine inlet 'B'

Through a reduction valve, compressed air is supplied at 10 bar to 'AP' for turbocharger cleaning (soft blast), and a minor volume used for the fuel valve testing unit.

Please note that the air consumption for control air, safety air, turbocharger cleaning, sealing air for exhaust valve and for fuel valve testing unit are momentary requirements of the consumers.

The components of the starting and control air systems are further described in Section 13.02.

For information about a common starting air system for main engines and MAN Diesel & Turbo auxiliary engines, please refer to our publication:

*Uni-concept Auxiliary Systems for Two-Stroke Main Engines and Four-Stroke Auxiliary Engines*

The publication is available at [www.marine.man.eu](http://www.marine.man.eu) → 'Two-Stroke' → 'Technical Papers'.

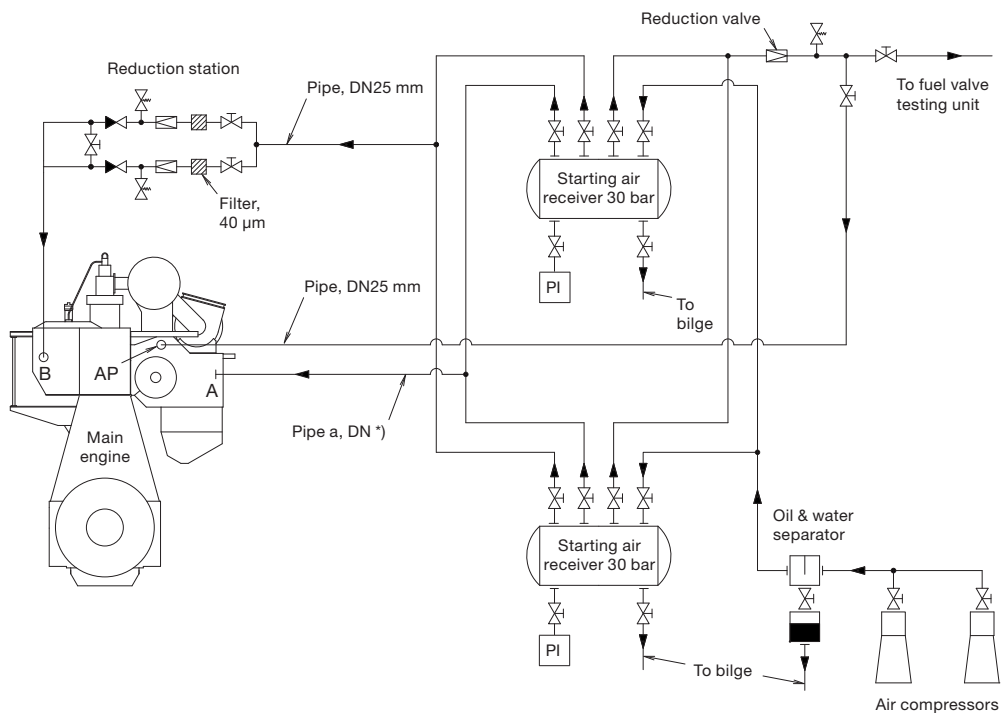

The letters refer to list of 'Counterflanges'  
) Pipe a nominal dimension: DN200 mm

078 83 76-7.3.0

Fig. 13.01.01: Starting and control air systems



### Components for Starting Air System

#### Starting air compressors

The starting air compressors are to be of the water-cooled, two-stage type with intercooling.

More than two compressors may be installed to supply the total capacity stated.

Air intake quantity:

- Reversible engine,  
for 12 starts ..... see 'List of capacities'
- Non-reversible engine,  
for 6 starts ..... see 'List of capacities'
- Delivery pressure ..... 30 bar

#### Starting air receivers

The volume of the two receivers is:

- Reversible engine,  
for 12 starts ..... see 'List of capacities' \*
- Non-reversible engine,  
for 6 starts ..... see 'List of capacities' \*
- Working pressure ..... 30 bar
- Test pressure ..... according to class rule

\* The volume stated is at 25 °C and 1,000 mbar

#### Reduction station for control and safety air

In normal operating, each of the two lines supplies one engine inlet. During maintenance, three isolating valves in the reduction station allow one of the two lines to be shut down while the other line supplies both engine inlets, see Fig. 13.01.01.

Reduction ..... from 30-10 bar to 7 bar  
(Tolerance ±10%)

Flow rate, free air ..... 2,100 Normal liters/min  
equal to 0.035 m<sup>3</sup>/s

Filter, fineness ..... 40 μm

#### Reduction valve for turbocharger cleaning etc

Reduction .....from 30-10 bar to 7 bar  
(Tolerance ±10%)

Flow rate, free air ..... 2,600 Normal liters/min  
equal to 0.043 m<sup>3</sup>/s

The consumption of compressed air for control air, exhaust valve air springs and safety air as well as air for turbocharger cleaning and fuel valve testing is covered by the capacities stated for air receivers and compressors in the list of capacities.

#### Starting and control air pipes

The piping delivered with and fitted onto the main engine is shown in the following figures in Section 13.03:

Fig. 13.03.01 Starting air pipes

Fig. 13.03.02 Air spring pipes, exhaust valves

#### Turning gear

The turning wheel has cylindrical teeth and is fitted to the thrust shaft. The turning wheel is driven by a pinion on the terminal shaft of the turning gear, which is mounted on the bedplate.

Engagement and disengagement of the turning gear is effected by displacing the pinion and terminal shaft axially. To prevent the main engine from starting when the turning gear is engaged, the turning gear is equipped with a safety arrangement which interlocks with the starting air system.

The turning gear is driven by an electric motor with a built-in gear and brake. Key specifications of the electric motor and brake are stated in Section 13.04.



### Starting and Control Air Pipes

The starting air pipes, Fig. 13.03.01, contain a main starting valve (a ball valve with actuator), a non-return valve, a solenoid valve and a starting valve. The main starting valve is controlled by the Engine Control System. Slow turning before start of engine, EoD: 4 50 140, is included in the basic design.

The Engine Control System regulates the supply of control air to the starting valves in accordance with the correct firing sequence and the timing.

Please note that the air consumption for control air, turbocharger cleaning and for fuel valve testing unit are momentary requirements of the consumers. The capacities stated for the air receivers

and compressors in the 'List of Capacities' cover all the main engine requirements and starting of the auxiliary engines.

For information about a common starting air system for main engines and auxiliary engines, please refer to our publication:

*Uni-concept Auxiliary Systems for Two-Stroke Main Engines and Four-Stroke Auxiliary Engines*

The publication is available at [www.marine.man.eu](http://www.marine.man.eu) → 'Two-Stroke' → 'Technical Papers'.

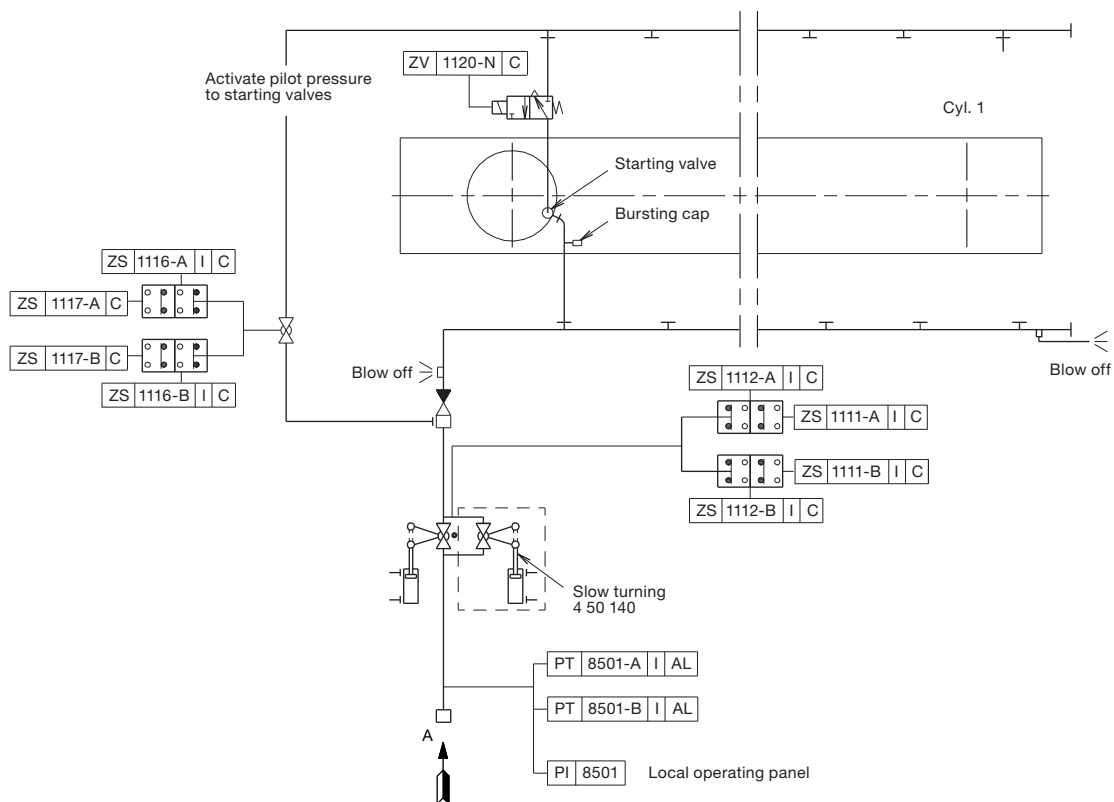

The letters refer to list of 'Counterflanges'  
The item Nos. refer to 'Guidance values automation'  
The piping is delivered with and fitted onto the engine

198 98 21-5.3

Fig. 13.03.01: Starting air pipes



### Exhaust Valve Air Spring Pipes

The exhaust valve is opened hydraulically by the Fuel Injection Valve Actuator (FIVA) system which is activated by the Engine Control System, and the closing force is provided by an 'air spring' which leaves the valve spindle free to rotate.

The compressed air is taken from the control air supply, see Fig. 13.03.02.

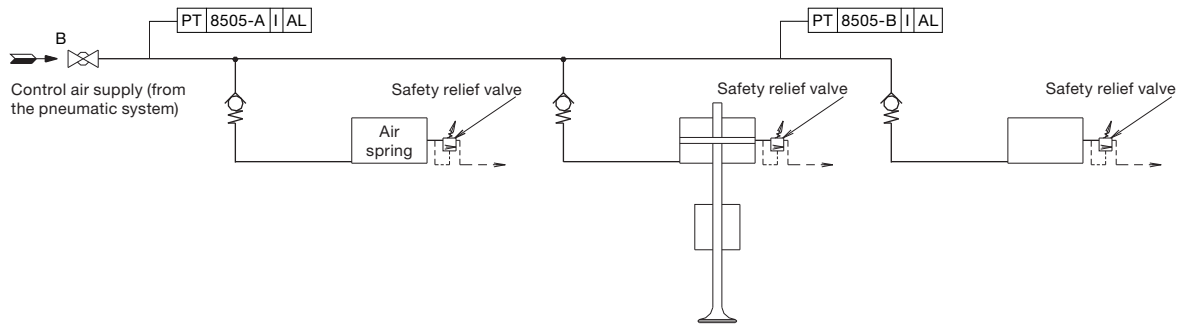

The item Nos. refer to 'Guidance values automation'  
The piping is delivered with and fitted onto the engine

121 36 87-1.1.1c

Fig. 13.03.02: Air spring pipes for exhaust valves



**MAN B&W**

---

Scavenge Air

14

---

**MAN Diesel**



### Scavenge Air System

Scavenge air is supplied to the engine by two or more turbochargers, located on the exhaust side of the engine.

The compressor of the turbocharger draws air from the engine room, through an air filter, and the compressed air is cooled by the scavenge air cooler, one per turbocharger. The scavenge air cooler is provided with a water mist catcher, which prevents condensate water from being carried with the air into the scavenge air receiver and to the combustion chamber.

The scavenge air system (see Figs. 14.01.01 and 14.02.01) is an integrated part of the main engine.

The engine power figures and the data in the list of capacities are based on MCR at tropical conditions, i.e. a seawater temperature of 32 °C, or freshwater temperature of 36 °C, and an ambient air inlet temperature of 45 °C.

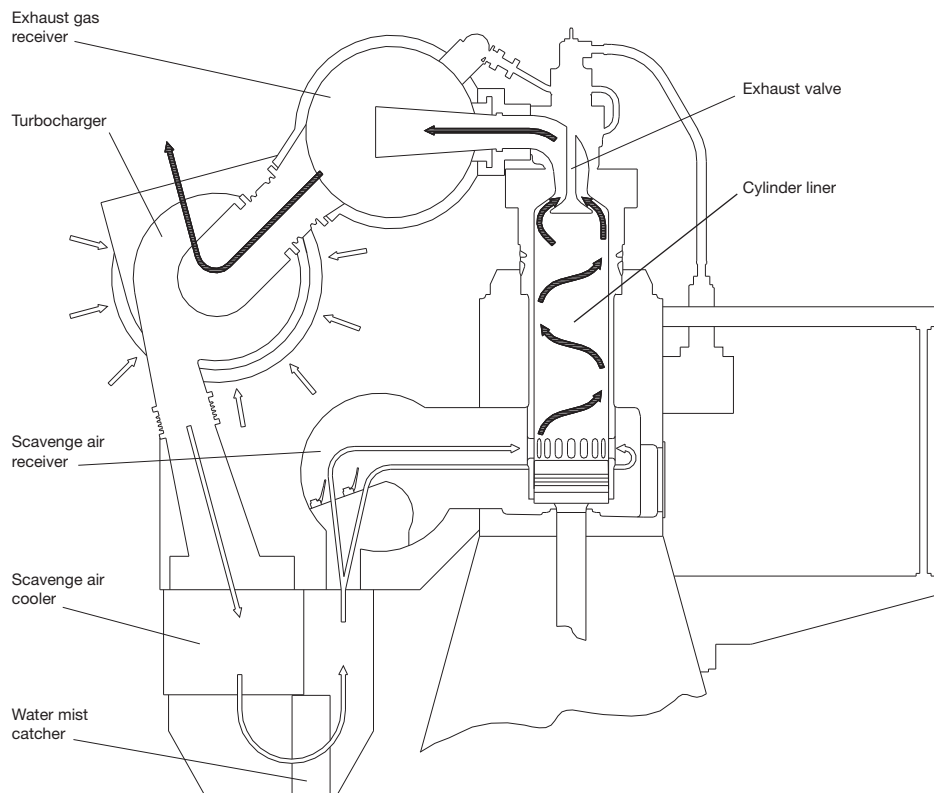

178 25 18-8.1

Fig. 14.01.01: Scavenge Air System





### Auxiliary Blowers

The engine is provided with a minimum of two electrically driven auxiliary blowers, the actual number depending on the number of cylinders as well as the turbocharger make and amount.

The auxiliary blowers are integrated in the reversing chamber below the scavenge air cooler. Between the scavenge air cooler and the scavenge air receiver, non-return valves are fitted which close automatically when the auxiliary blowers start supplying the scavenge air.

During operation of the engine, the auxiliary blowers will start automatically whenever the blower inlet pressure drops below a preset pressure, corresponding to an engine load of approximately 25-35%.

The blowers will continue to operate until the blower inlet pressure again exceeds the preset pressure plus an appropriate hysteresis (i.e. taking recent pressure history into account), corresponding to an engine load of approximately 30-40%.

### Auxiliary blower operation

The auxiliary blowers start operating consecutively before the engine is started and will ensure complete scavenging of the cylinders in the starting phase, thus providing the best conditions for a safe start.

### Emergency running

If one of the auxiliary blowers is out of function, the other auxiliary blower will function in the system, without any manual adjustment of the valves being necessary.

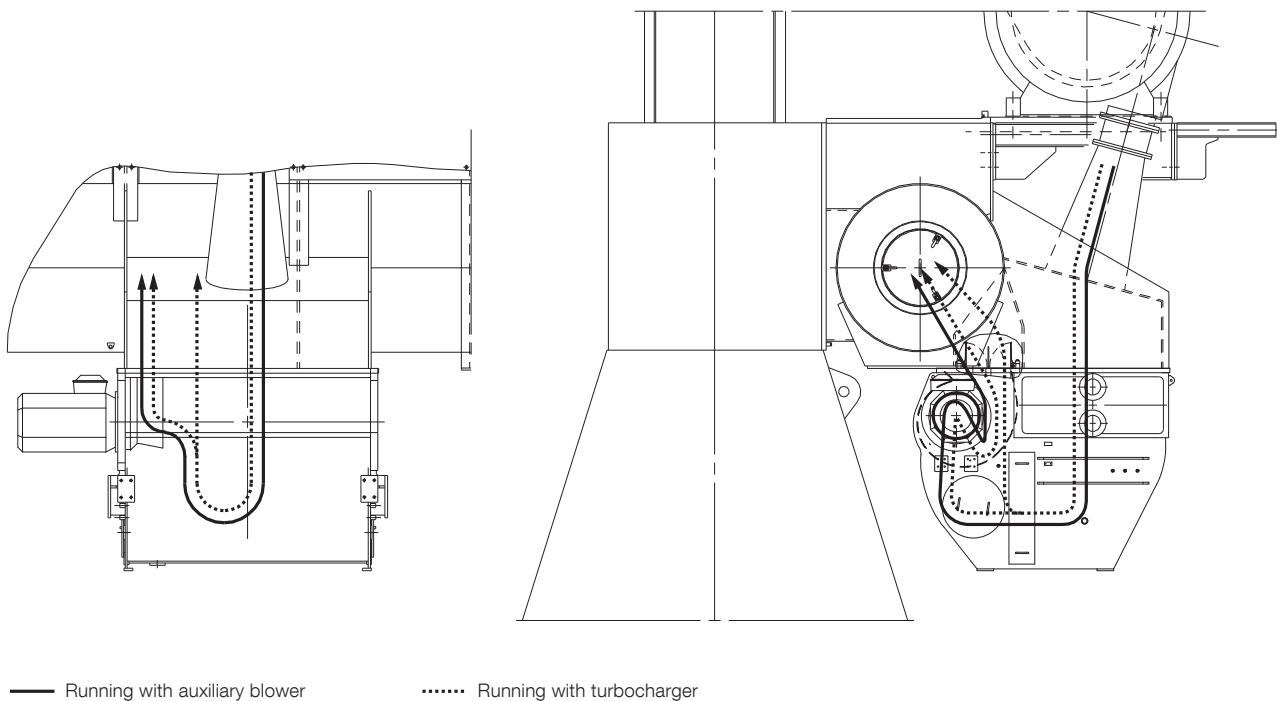

178 63 77-1.0

Fig. 14.02.01: Scavenge air system, integrated blower



### Control of the Auxiliary Blowers

The control system for the auxiliary blowers is integrated in the Engine Control System. The auxiliary blowers can be controlled in either automatic (default) or manual mode.

In automatic mode, the auxiliary blowers are started sequentially at the moment the engine is commanded to start. During engine running, the blowers are started and stopped according to preset scavenge air pressure limits.

When the engine stops, the blowers are stopped after 10 minutes to prevent overheating of the blowers. When a start is ordered, the blower will be started in the normal sequence and the actual start of the engine will be delayed until the blowers have started.

In manual mode, the blowers can be controlled individually from the ECR (Engine Control Room) panel irrespective of the engine condition.

Referring to Fig. 14.02.02, the Auxiliary Blower Starter Panels control and protect the Auxiliary Blower motors, one panel with starter per blower.

The starter panels with starters for the auxiliary blower motors are not included, they can be ordered as an option: 4 55 653. (The starter panel design and function is according to MAN Diesel & Turbo's diagram, however, the physical layout and choice of components has to be decided by the manufacturer).

Heaters for the blower motors are available as an option: 4 55 155.

### Scavenge air cooler requirements

The data for the scavenge air cooler is specified in the description of the cooling water system chosen.

For further information, please refer to our publication titled:

*MAN Diesel & Turbo Influence of Ambient Temperature Conditions*

The publication is available at [www.marine.man.eu](http://www.marine.man.eu) → 'Two-Stroke' → 'Technical Papers'.

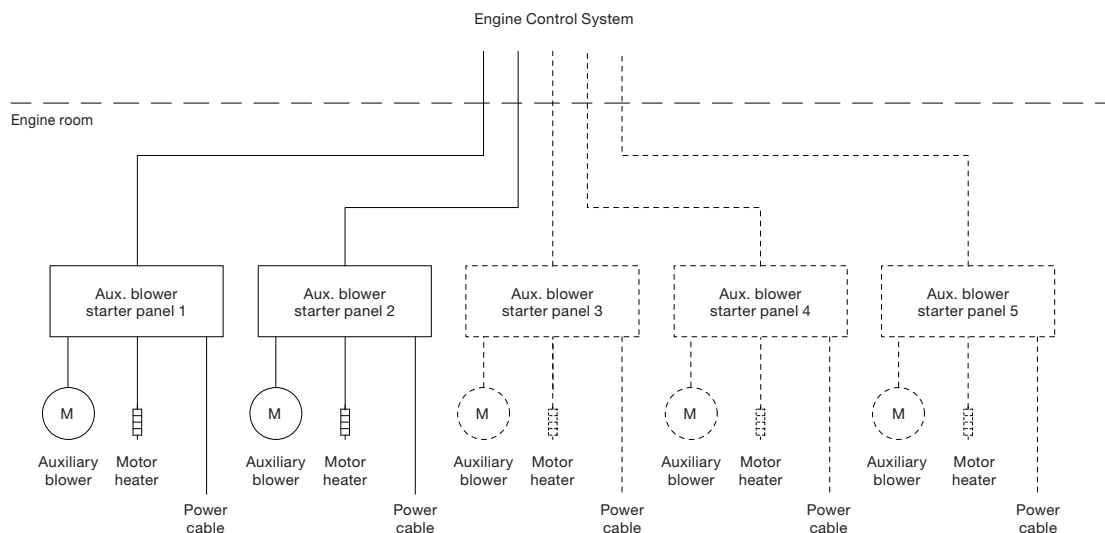

178 61 30-2.0

Fig. 14.02.02: Diagram of auxiliary blower control system



### Scavenge Air Pipes

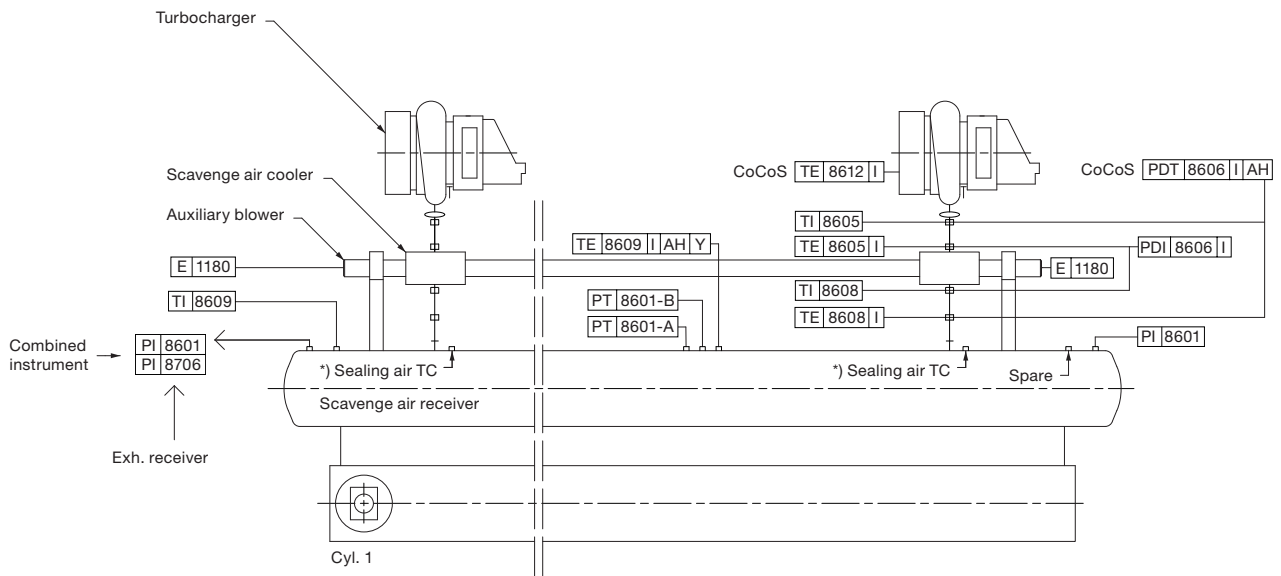

525 11 86-5.0.1

The item No. refer to 'Guidance Values Automation'

\*) Option, see Fig. 15.02.05: Soft blast cleaning of turbine side

Fig. 14.03.01: Scavenge air pipes



## Electric Motor for Auxiliary Blower

The number of auxiliary blowers in a propulsion plant may vary depending on the actual amount of turbochargers as well as space requirements.

### Motor start method and size

Direct Online Start (DOL) is required for all auxiliary blower electric motors to ensure proper operation under all conditions.

For typical engine configurations, the installed size of the electric motors for auxiliary blowers are listed in Table 14.04.01.

### Special operating conditions

For engines with Dynamic Positioning (DP) mode in manoeuvring system, option: 4 06 111, larger electric motors are required. This is in order to avoid start and stop of the blowers inside the load range specified for dynamic positioning. The actual load range is to be decided between the owner and the yard.

Engine plants with waste heat recovery exhaust gas bypass and engines with low- and part-load exhaust gas bypass may require less blower capacity, please contact MAN Diesel & Turbo, Copenhagen.

Number of cylinders	Number of turbochargers	Number of auxiliary blowers	Installed power/blower kW
5	2	2	125
6	2	2	155
7	2	3	105
8	2	3	125
8	3	3	125
9	3	3	155
10	3	4	125
11	3	4	125
12	3	4	155
12	4	4	155

The installed power of the electric motors are based on a voltage supply of 3x440V at 60Hz.

The electric motors are delivered with and fitted onto the engine.

Table 14.04.01: Electric motor for auxiliary blower



### Scavenge Air Cooler Cleaning System

The air side of the scavenge air cooler can be cleaned by injecting a grease dissolving media through 'AK' to a spray pipe arrangement fitted to the air chamber above the air cooler element.

The system is equipped with a drain box with a level switch, indicating any excessive water level.

The piping delivered with and fitted on the engine is shown in Fig 14.05.01.

### Drain from water mist catcher

Sludge is drained through 'AL' to the drain water collecting tank and the polluted grease dissolvent returns from 'AM', through a filter, to the chemical cleaning tank. The cleaning must be carried out while the engine is at standstill.

Dirty water collected after the water mist catcher is drained through 'DX' and led to the bilge tank via an open funnel, see Fig. 14.05.02.

The 'AL' drain line is, during running, used as a permanent drain from the air cooler water mist catcher. The water is led through an orifice to prevent major losses of scavenge air.

### Auto Pump Overboard System

It is common practice on board to lead drain water directly overboard via a collecting tank. Before pumping the drain water overboard, it is recommended to measure the oil content. If above 15ppm, the drain water should be lead to the clean bilge tank / bilge holding tank.

If required by the owner, a system for automatic disposal of drain water with oil content monitoring could be built as outlined in Fig. 14.05.02.

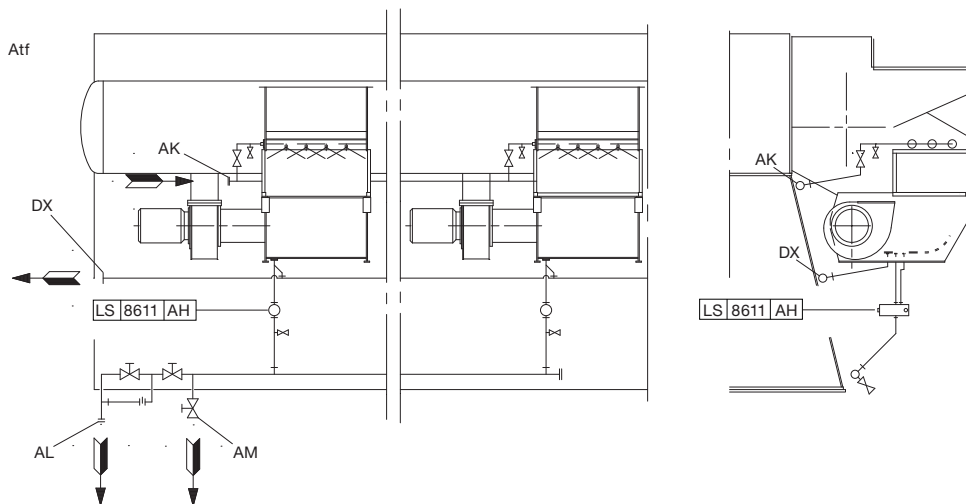

With two or more air cooler  
The letters refer to list of 'Counterflanges'  
The item no refer to 'Guidance values automation'

509 22 67-3.5.0

Fig. 14.05.01: Air cooler cleaning pipes



Auto Pump Overboard System

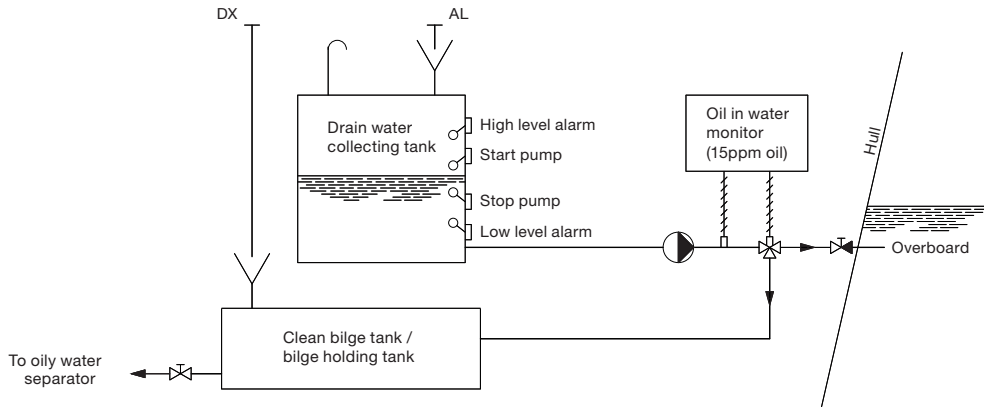

079 21 94-1.0.0c

Fig. 14.05.02: Suggested automatic disposal of drain water, if required by owner (not a demand from MAN Diesel & Turbo)

Air Cooler Cleaning Unit

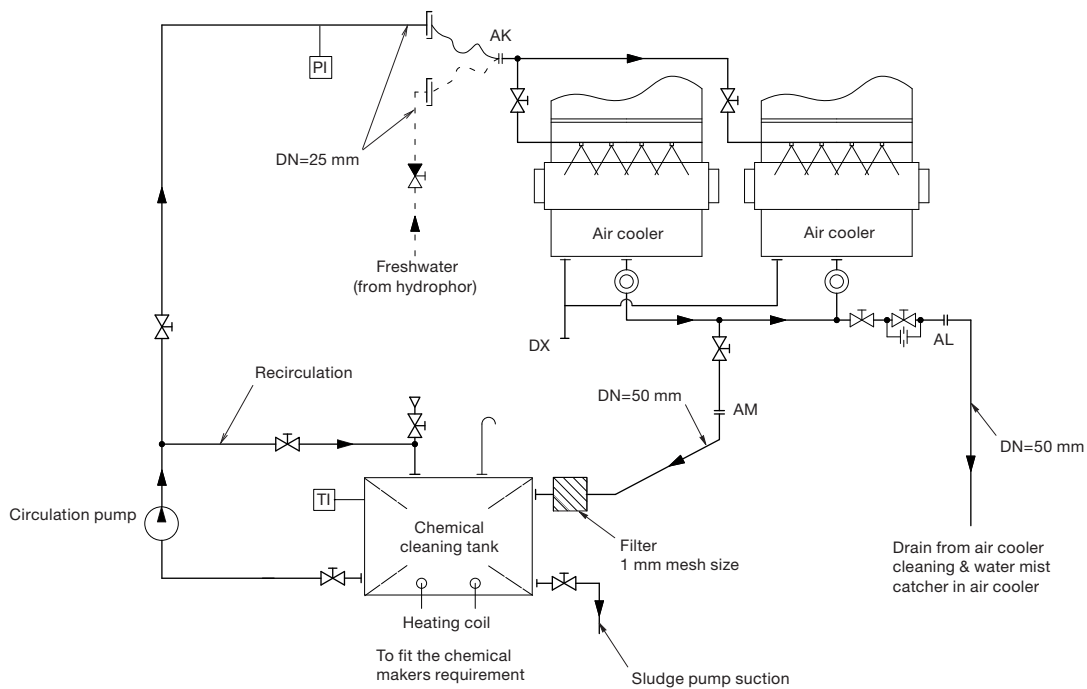

The letters refer to list of 'Counterflanges'

079 21 94-1.1.0a

	No. of cylinders	
	5-8	9-12
Chemical tank capacity, m <sup>3</sup>	0.9	1.5
Circulation pump capacity at 3 bar, m <sup>3</sup> /h	3	5

079 61 05-4.2.1

Fig. 14.05.03: Air cooler cleaning system with Air Cooler Cleaning Unit, option: 4 55 665



### Scavenge Air Box Drain System

The scavenge air box is continuously drained through 'AV' to a small pressurised drain tank, from where the sludge is led to the sludge tank. Steam can be applied through 'BV', if required, to facilitate the draining. See Fig. 14.06.01.

The continuous drain from the scavenge air box must not be directly connected to the sludge tank owing to the scavenge air pressure.

The pressurised drain tank must be designed to withstand full scavenge air pressure and, if steam is applied, to withstand the steam pressure available.

The system delivered with and fitted on the engine is shown in Fig. 14.07.03 Scavenge air space, drain pipes.

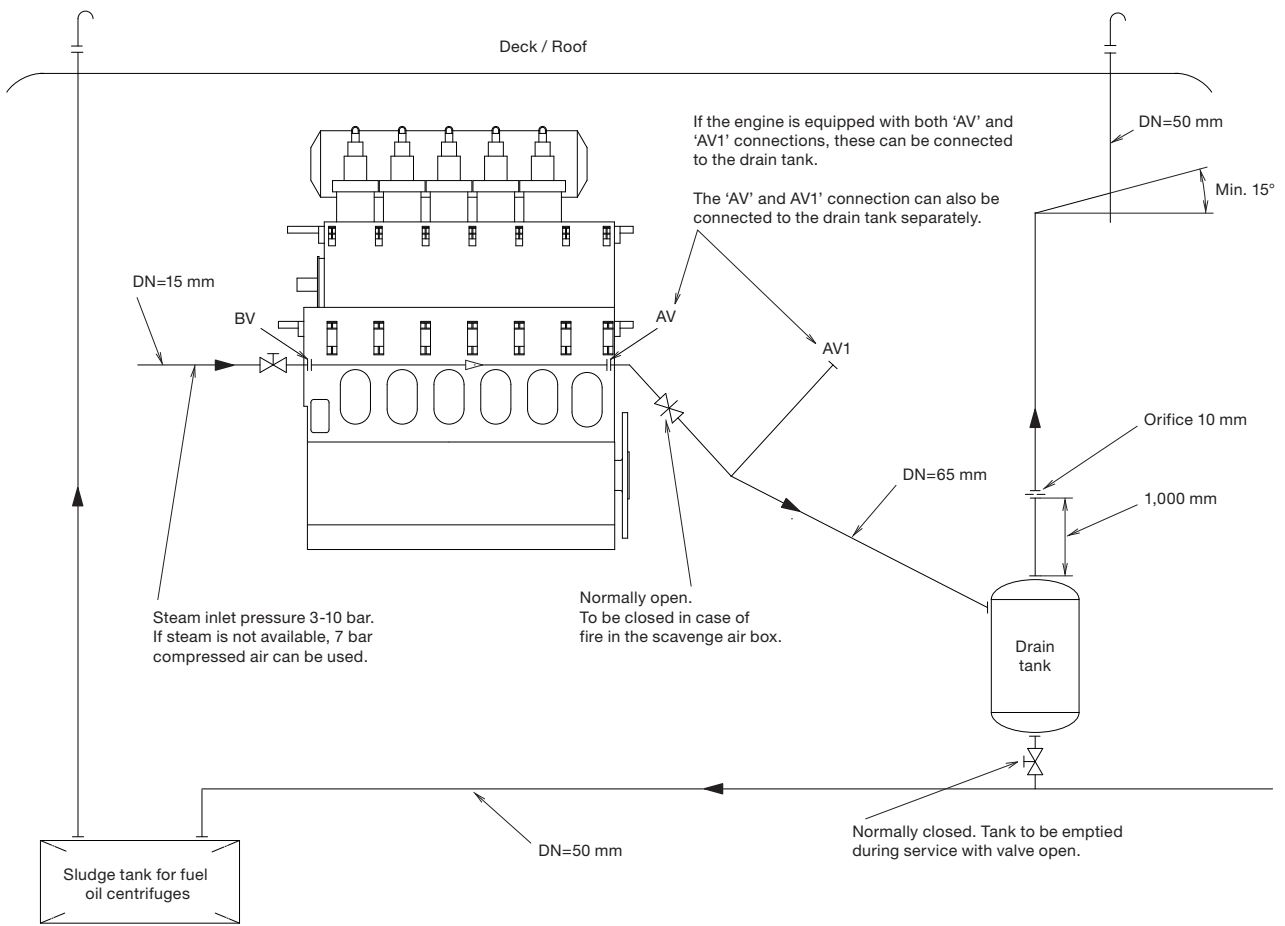

The letters refer to list of 'Counterflanges'

No. of cylinders:	6	7-9	10-12
Drain tank capacity, m <sup>3</sup>	1.0	1.4	1.8

Fig. 14.06.01: Scavenge air box drain system

079 61 03-0.4.1



### Fire Extinguishing System for Scavenge Air Space

Fire in the scavenge air space can be extinguished by steam, this being the basic solution, or, optionally, by water mist or CO<sub>2</sub>.

The external system, pipe and flange connections are shown in Fig. 14.07.01 and the piping fitted onto the engine in Fig. 14.07.02.

In the Extent of Delivery, the fire extinguishing system for scavenge air space is selected by the fire extinguishing agent:

- basic solution: 4 55 140 Steam
- option: 4 55 142 Water mist
- option: 4 55 143 CO<sub>2</sub>

The key specifications of the fire extinguishing agents are:

Steam fire extinguishing for scavenge air space  
 Steam pressure: 3-10 bar  
 Steam quantity, approx.: 13.0 kg/cyl.

Water mist fire extinguishing for scavenge air space  
 Freshwater pressure: min. 3.5 bar  
 Freshwater quantity, approx.: 9.0 kg/cyl.

CO<sub>2</sub> fire extinguishing for scavenge air space  
 CO<sub>2</sub> test pressure: 150 bar  
 CO<sub>2</sub> quantity, approx.: 24.0 kg/cyl.

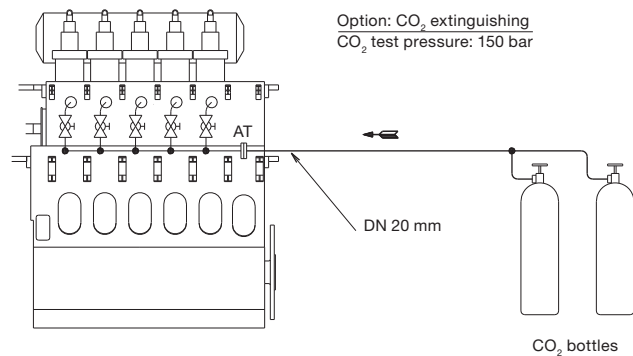
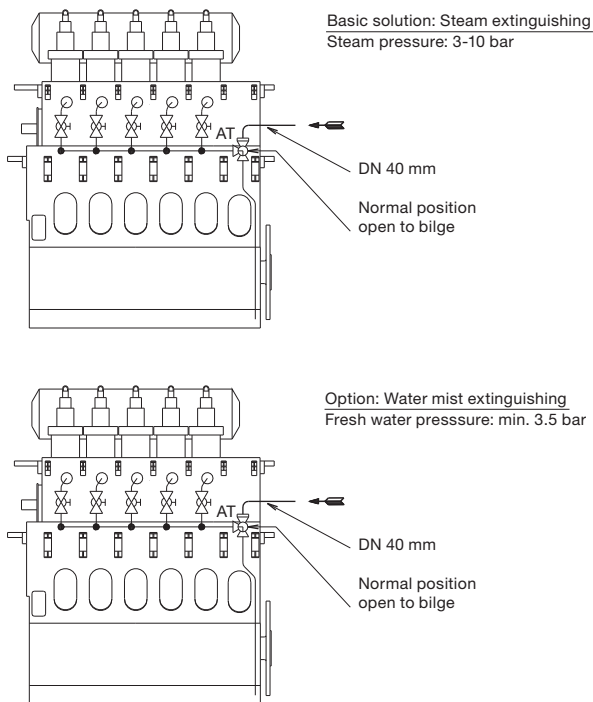

CO<sub>2</sub>

At least two bottles ought to be installed. In most cases, one bottle should be sufficient to extinguish fire in three cylinders, while two or more bottles would be required to extinguish fire in all cylinders.

To prevent the fire from spreading to the next cylinder(s), the ball-valve of the neighbouring cylinder(s) should be opened in the event of fire in one cylinder.

079 61 02-9.3.0a

The letters refer to list of 'Counterflanges'

Fig. 14.07.01: Fire extinguishing system for scavenge air space





**MAN B&W**

---

---

Exhaust Gas

15

---

---

**MAN Diesel**



### Exhaust Gas System

The exhaust gas is led from the cylinders to the exhaust gas receiver where the fluctuating pressures from the cylinders are equalised and from where the gas is led further on to the turbocharger at a constant pressure. See fig. 15.01.01.

Compensators are fitted between the exhaust valve housings and the exhaust gas receiver and between the receiver and the turbocharger. A protective grating is placed between the exhaust gas receiver and the turbocharger. The turbocharger is fitted with a pick-up for monitoring and remote indication of the turbocharger speed.

The exhaust gas receiver and the exhaust pipes are provided with insulation, covered by steel plating.

### Turbocharger arrangement and cleaning systems

The turbochargers are located on the exhaust side of the engine.

The engine is designed for the installation of the MAN turbocharger type TCA, option: 4 59 101, ABB turbocharger type A-L, option: 4 59 102, or MHI turbocharger type MET, option: 4 59 103.

All makes of turbochargers are fitted with an arrangement for water washing of the compressor side, and soft blast cleaning of the turbine side, see Figs. 15.02.02, 15.02.03 and 15.02.04. Washing of the turbine side is only applicable on MAN turbochargers.

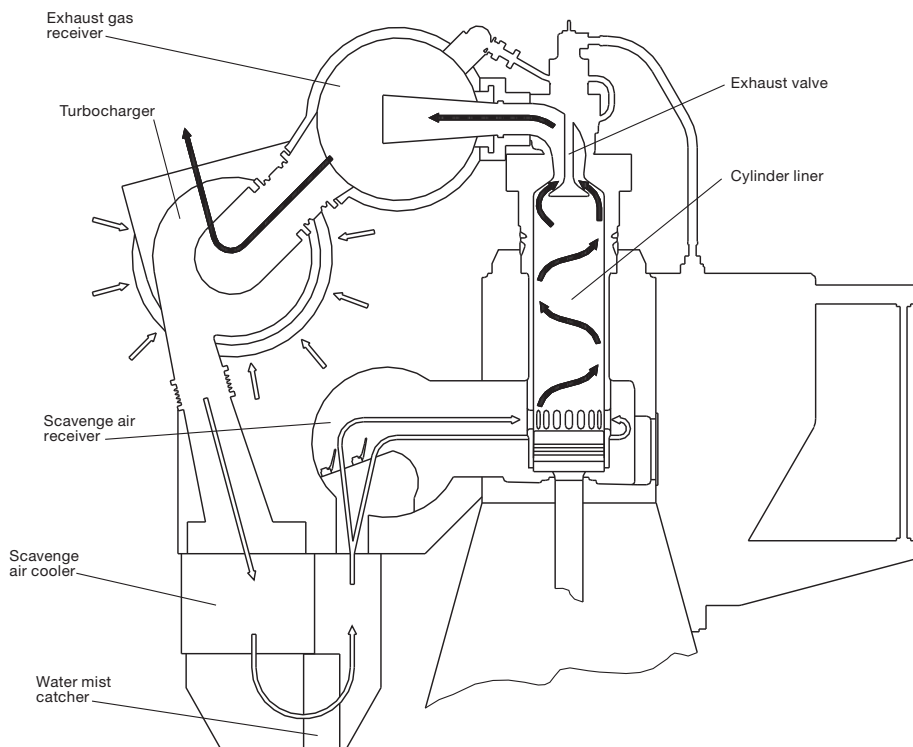

178 07 27-4.1

Fig. 15.01.01: Exhaust gas system on engine



### Exhaust Gas Pipes

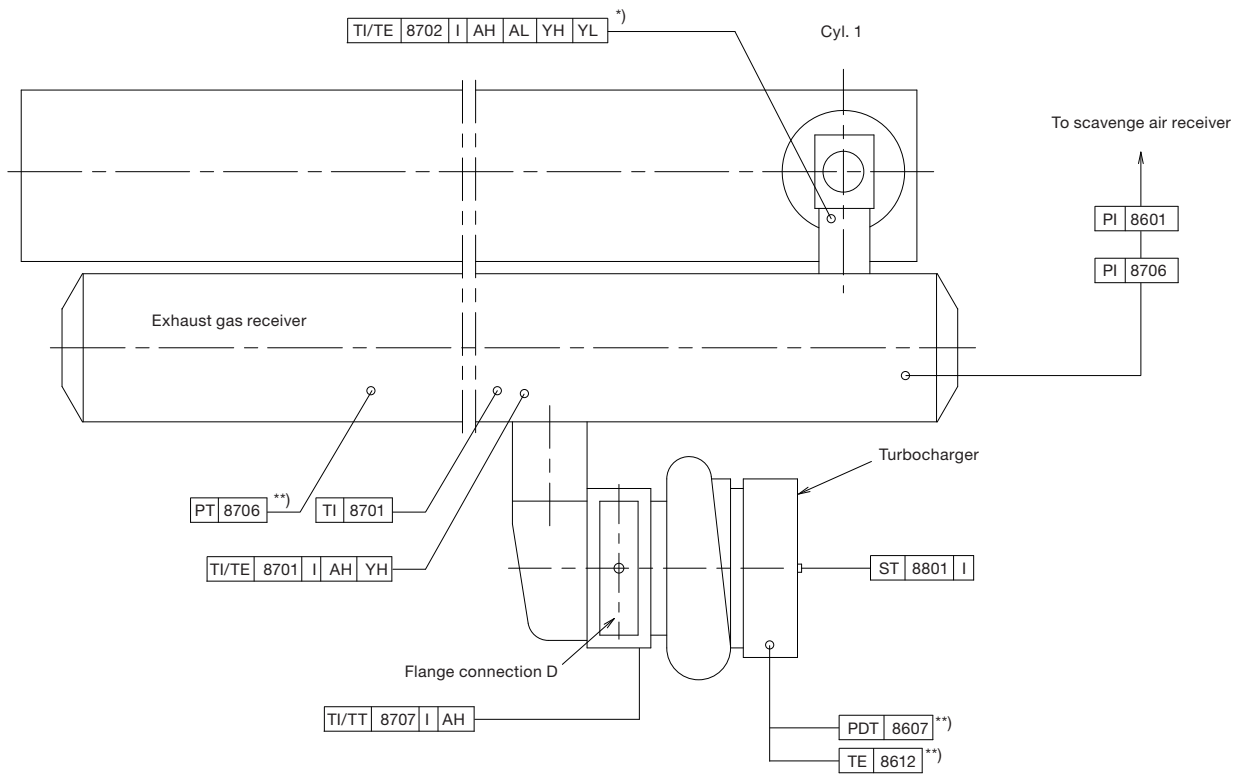

\*) AL: Deviation alarm/Cylinder  $\pm 50^{\circ}\text{C}$   
 YL: Deviation alarm/Cylinder  $\pm 60^{\circ}\text{C}$

\*\*)CoCos

The letters refer to list of 'Counterflanges'  
 The item no. refer to 'Guidance Values Automation'

121 15 27-9.2.1

Fig. 15.02.01: Exhaust gas pipes



### Cleaning Systems

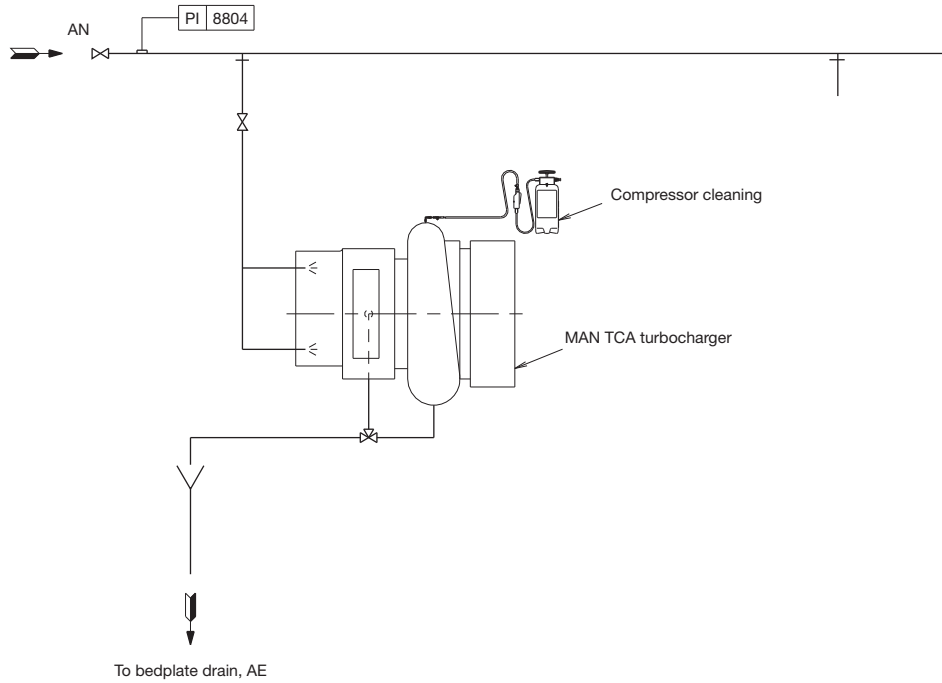

121 15 21-8.1.1

Fig. 15.02.02: MAN TCA turbocharger, water washing of turbine side

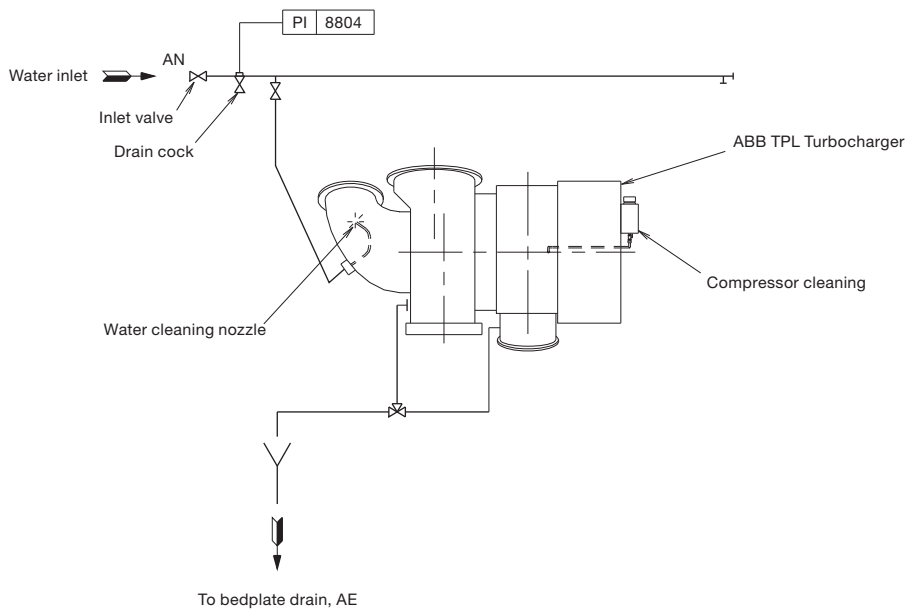

121 36 75-1.1.0

Fig. 15.02.03: Water washing of turbine and compressor sides for ABB TPL turbochargers



### Soft Blast Cleaning Systems

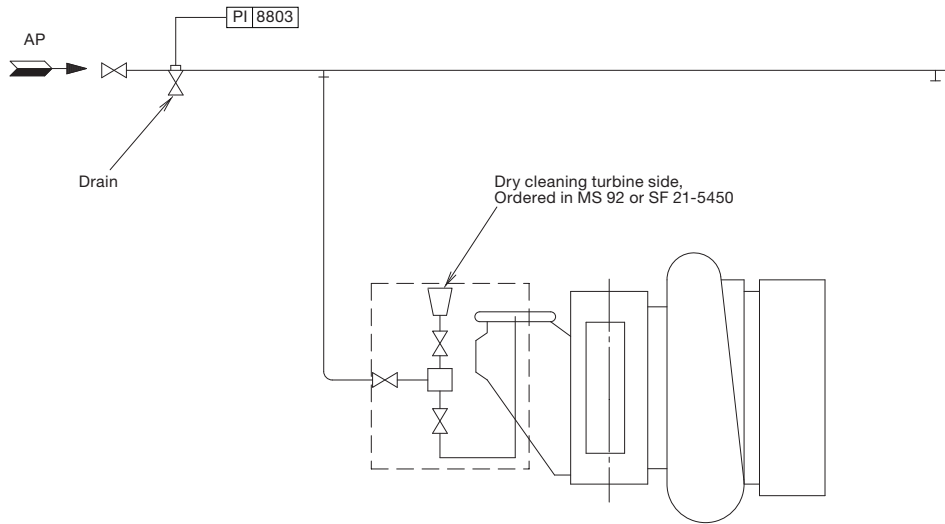

514 69 25-5.1.0

Fig. 15.02.04: Soft blast cleaning of turbine side, basic

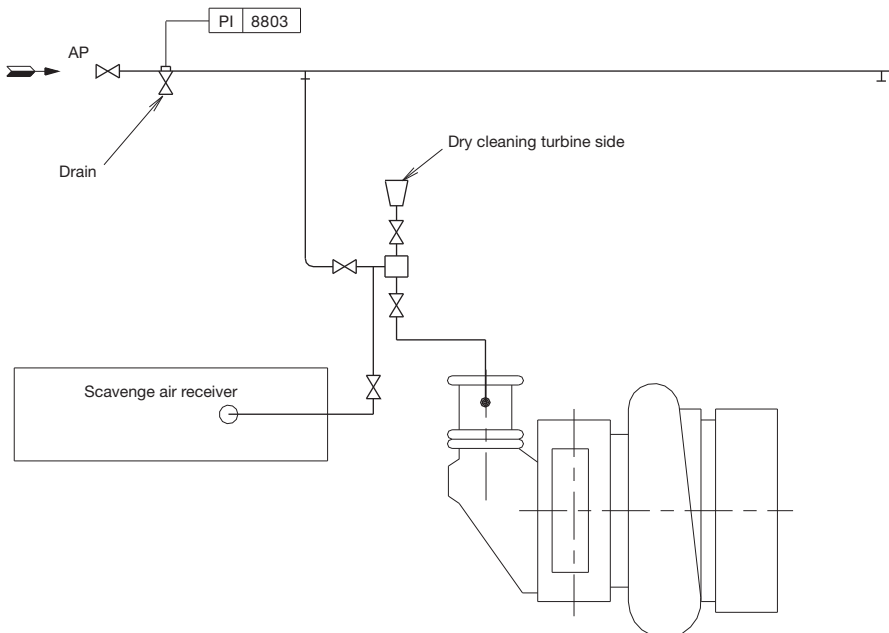

121 36 88-3.2.0

Fig. 15.02.05: Soft blast cleaning of turbine side, option



## Exhaust Gas System for Main Engine

At the specified MCR of the engine, the total back-pressure in the exhaust gas system after the turbocharger (as indicated by the static pressure measured in the piping after the turbocharger) must not exceed 350 mm WC (0.035 bar).

In order to have a back-pressure margin for the final system, it is recommended at the design stage to initially use a value of about 300 mm WC (0.030 bar).

The actual back-pressure in the exhaust gas system at specified MCR depends on the gas velocity, i.e. it is proportional to the square of the exhaust gas velocity, and hence inversely proportional to the pipe diameter to the 4th power. It has by now become normal practice in order to avoid too much pressure loss in the pipings to have an exhaust gas velocity at specified MCR of about 35 m/sec, but not higher than 50 m/sec.

For dimensioning of the external exhaust pipe connections, see the exhaust pipe diameters for 35 m/sec, 40 m/sec, 45 m/sec and 50 m/sec respectively, shown in Table 15.07.02.

As long as the total back-pressure of the exhaust gas system (incorporating all resistance losses from pipes and components) complies with the above-mentioned requirements, the pressure losses across each component may be chosen independently, see proposed measuring points (M) in Fig. 15.05.01. The general design guidelines for each component, described below, can be used for guidance purposes at the initial project stage.

### Exhaust gas piping system for main engine

The exhaust gas piping system conveys the gas from the outlet of the turbocharger(s) to the atmosphere.

The exhaust piping is shown schematically in Fig. 15.04.01.

The exhaust system for the main engine comprises:

- Exhaust gas pipes
- Exhaust gas boiler
- Silencer
- Spark arrester (if needed)
- Expansion joints (compensators)
- Pipe bracings.

In connection with dimensioning the exhaust gas piping system, the following parameters must be observed:

- Exhaust gas flow rate
- Exhaust gas temperature at turbocharger outlet
- Maximum pressure drop through exhaust gas system
- Maximum noise level at gas outlet to atmosphere
- Maximum force from exhaust piping on turbocharger(s)
- Sufficient axial and lateral elongation ability of expansion joints
- Utilisation of the heat energy of the exhaust gas.

Items that are to be calculated or read from tables are:

- Exhaust gas mass flow rate, temperature and maximum back pressure at turbocharger gas outlet
- Diameter of exhaust gas pipes
- Utilisation of the exhaust gas energy
- Attenuation of noise from the exhaust pipe outlet
- Pressure drop across the exhaust gas system
- Expansion joints.



### Components of the Exhaust Gas System

#### Exhaust gas compensator after turbocharger

When dimensioning the compensator, option: 4 60 610, for the expansion joint on the turbocharger gas outlet transition piece, option: 4 60 601, the exhaust gas piece and components, are to be so arranged that the thermal expansions are absorbed by expansion joints. The heat expansion of the pipes and the components is to be calculated based on a temperature increase from 20 °C to 250 °C. The max. expected vertical, transversal and longitudinal heat expansion of the engine measured at the top of the exhaust gas transition piece of the turbocharger outlet are indicated in Fig. 15.06.01 and Table 15.06.02 as DA, DB and DC.

The movements stated are related to the engine seating, for DC, however, to the engine centre. The figures indicate the axial and the lateral movements related to the orientation of the expansion joints.

The expansion joints are to be chosen with an elasticity that limits the forces and the moments of the exhaust gas outlet flange of the turbocharger as stated for each of the turbocharger makers in Table 15.06.04. The orientation of the maximum permissible forces and moments on the gas outlet flange of the turbocharger is shown in Fig. 15.06.03.

#### Exhaust gas boiler

Engine plants are usually designed for utilisation of the heat energy of the exhaust gas for steam production or for heating the thermal oil system. The exhaust gas passes an exhaust gas boiler which is usually placed near the engine top or in the funnel.

It should be noted that the exhaust gas temperature and flow rate are influenced by the ambient conditions, for which reason this should be considered when the exhaust gas boiler is planned. At specified MCR, the maximum recommended pressure loss across the exhaust gas boiler is normally 150 mm WC.

This pressure loss depends on the pressure losses in the rest of the system as mentioned above. Therefore, if an exhaust gas silencer/spark arrester is not installed, the acceptable pressure loss across the boiler may be somewhat higher than the max. of 150 mm WC, whereas, if an exhaust gas silencer/spark arrester is installed, it may be necessary to reduce the maximum pressure loss.

The above mentioned pressure loss across the exhaust gas boiler must include the pressure losses from the inlet and outlet transition pieces.

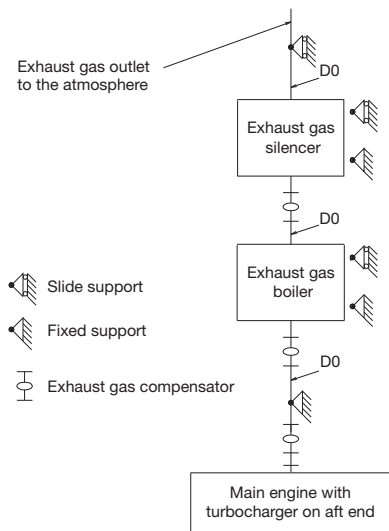

178 42 78-3.2

Fig. 15.04.01a: Exhaust gas system, one turbocharger

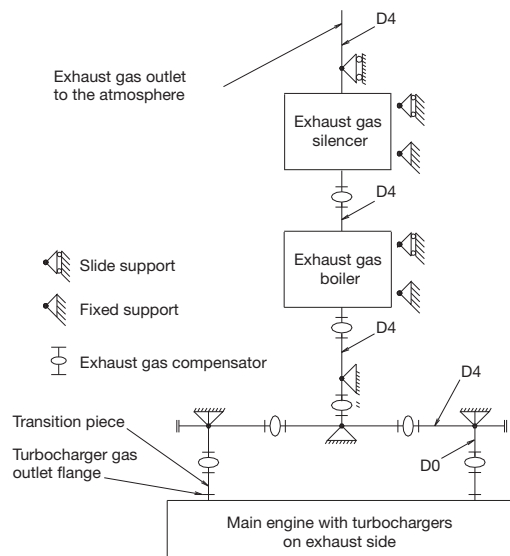

178 33 46-7.4

Fig. 15.04.01b: Exhaust gas system, two or more TCs



## Calculation of Exhaust Gas Back-Pressure

The exhaust gas back pressure after the turbo-charger(s) depends on the total pressure drop in the exhaust gas piping system.

The components, exhaust gas boiler, silencer, and spark arrester, if fitted, usually contribute with a major part of the dynamic pressure drop through the entire exhaust gas piping system.

The components mentioned are to be specified so that the sum of the dynamic pressure drop through the different components should, if possible, approach 200 mm WC at an exhaust gas flow volume corresponding to the specified MCR at tropical ambient conditions. Then there will be a pressure drop of 100 mm WC for distribution among the remaining piping system.

Fig. 15.05.01 shows some guidelines regarding resistance coefficients and back-pressure loss calculations which can be used, if the maker's data for back-pressure is not available at an early stage of the project.

The pressure loss calculations have to be based on the actual exhaust gas amount and temperature valid for specified MCR. Some general formulas and definitions are given in the following.

### Exhaust gas data

M: exhaust gas amount at specified MCR in kg/sec.  
T: exhaust gas temperature at specified MCR in °C

Please note that the actual exhaust gas temperature is different before and after the boiler. The exhaust gas data valid after the turbocharger may be found in Chapter 6.

### Mass density of exhaust gas ( $\rho$ )

$$\rho \cong 1.293 \times \frac{273}{273 + T} \times 1.015 \text{ in kg/m}^3$$

The factor 1.015 refers to the average back-pressure of 150 mm WC (0.015 bar) in the exhaust gas system.

### Exhaust gas velocity ( $v$ )

In a pipe with diameter D the exhaust gas velocity is:

$$v = \frac{M}{\rho} \times \frac{4}{\pi \times D^2} \text{ in m/s}$$

### Pressure losses in pipes ( $\Delta p$ )

For a pipe element, like a bend etc., with the resistance coefficient  $\zeta$ , the corresponding pressure loss is:

$$\Delta p = \zeta \times \frac{1}{2} \rho v^2 \times \frac{1}{9.81} \text{ in mm WC}$$

where the expression after  $\zeta$  is the dynamic pressure of the flow in the pipe.

The friction losses in the straight pipes may, as a guidance, be estimated as :

$$1 \text{ mm WC per } 1 \text{ diameter length}$$

whereas the positive influence of the up-draught in the vertical pipe is normally negligible.

### Pressure losses across components ( $\Delta p$ )

The pressure loss  $\Delta p$  across silencer, exhaust gas boiler, spark arrester, rain water trap, etc., to be measured/ stated as shown in Fig. 15.05.01 (at specified MCR) is normally given by the relevant manufacturer.

### Total back-pressure ( $\Delta p_M$ )

The total back-pressure, measured/stated as the static pressure in the pipe after the turbocharger, is then:

$$\Delta p_M = \Sigma \Delta p$$

where  $\Delta p$  incorporates all pipe elements and components etc. as described:

$$\Delta p_M \text{ has to be lower than } 350 \text{ mm WC.}$$

(At design stage it is recommended to use max. 300 mm WC in order to have some margin for fouling).





### **Measuring Back Pressure**

At any given position in the exhaust gas system, the total pressure of the flow can be divided into dynamic pressure (referring to the gas velocity) and static pressure (referring to the wall pressure, where the gas velocity is zero).

At a given total pressure of the gas flow, the combination of dynamic and static pressure may change, depending on the actual gas velocity. The measurements, in principle, give an indication of the wall pressure, i.e., the static pressure of the gas flow.

It is, therefore, very important that the back pressure measuring points are located on a straight part of the exhaust gas pipe, and at some distance from an 'obstruction', i.e. at a point where the gas flow, and thereby also the static pressure, is stable. Taking measurements, for example, in a transition piece, may lead to an unreliable measurement of the static pressure.

In consideration of the above, therefore, the total back pressure of the system has to be measured after the turbocharger in the circular pipe and not in the transition piece. The same considerations apply to the measuring points before and after the exhaust gas boiler, etc.



Pressure losses and coefficients of resistance in exhaust pipes

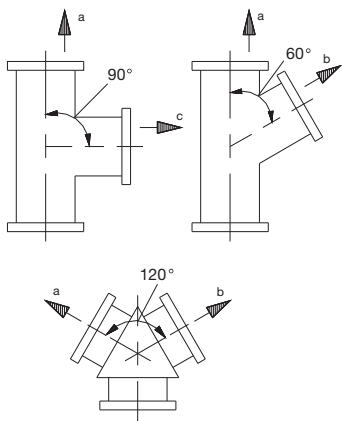

Change-over valves

Change-over valve of type with constant cross section

$\zeta_a = 0.6$  to  $1.2$   
 $\zeta_b = 1.0$  to  $1.5$   
 $\zeta_c = 1.5$  to  $2.0$

Change-over valve of type with volume

$\zeta_a = \zeta_b =$  about  $2.0$

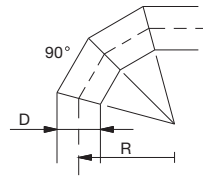

$R = D$        $\zeta = 0.28$   
 $R = 1.5D$      $\zeta = 0.20$   
 $R = 2D$        $\zeta = 0.17$

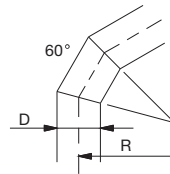

$R = D$        $\zeta = 0.16$   
 $R = 1.5D$      $\zeta = 0.12$   
 $R = 2D$        $\zeta = 0.11$

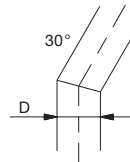

$\zeta = 0.05$

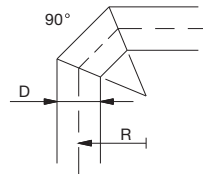

$R = D$        $\zeta = 0.45$   
 $R = 1.5D$      $\zeta = 0.35$   
 $R = 2D$        $\zeta = 0.30$

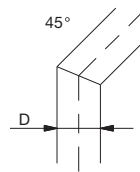

$\zeta = 0.14$



Outlet from top of exhaust gas uptake     $\zeta = 1.00$

Inlet (from turbocharger)     $\zeta = -1.00$

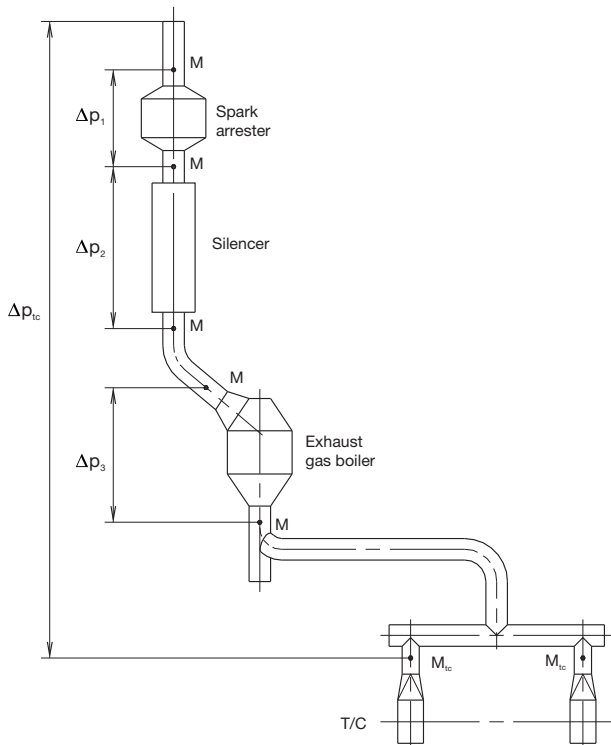

M: Measuring points

178 32 09-1.0

178 06 85-3.0

Fig. 15.05.01: Pressure losses and coefficients of resistance in exhaust pipes



### Forces and Moments at Turbocharger

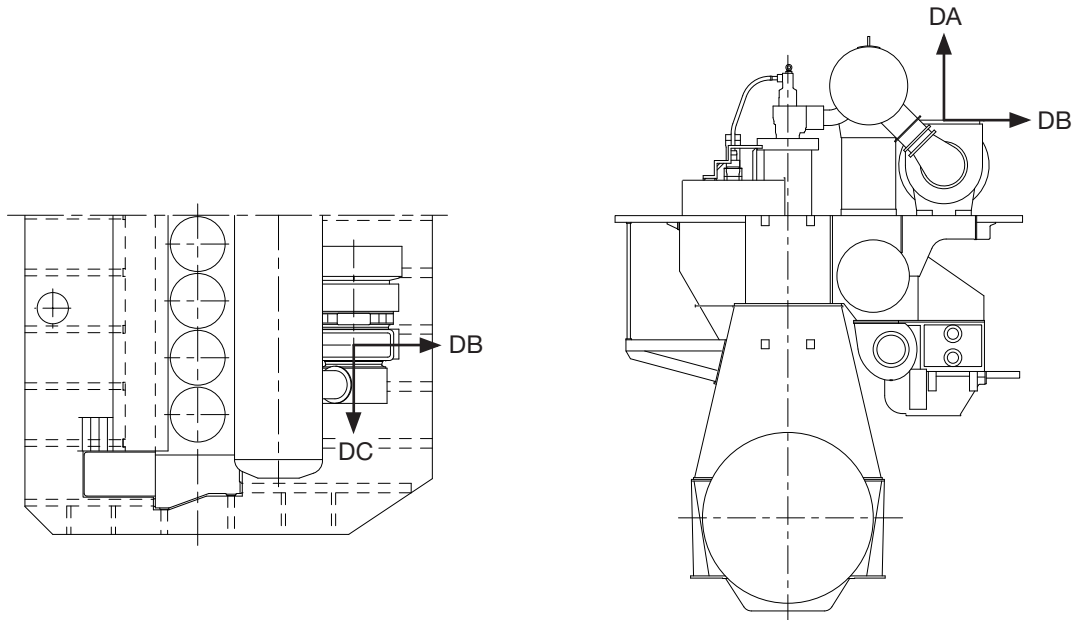

DA: Max. movement of the turbocharger flange in the vertical direction  
 DB: Max. movement of the turbocharger flange in the transversal direction  
 DC: Max. movement of the turbocharger flange in the longitudinal direction

078 87 11-1.0.0b

Fig. 15.06.01: Vectors of thermal expansion at the turbocharger exhaust gas outlet flange

No. of cylinders		6-14		6	7	8	9	10	11	12	13	14
Turbocharger Make	Type	DA	DB	DC	DC	DC	DC	DC	DC	DC	DC	DC
		mm	mm	mm	mm	mm	mm	mm	mm	mm	mm	mm
MAN	TCA77	Available on request										
	TCA88											
ABB	A275	Available on request										
	A280											
	A185 / A285											
	A190											
MHI	MET71	Available on request										
	MET83											
	MET90											

Table 15.06.02: Max. expected movements of the exhaust gas flange resulting from thermal expansion

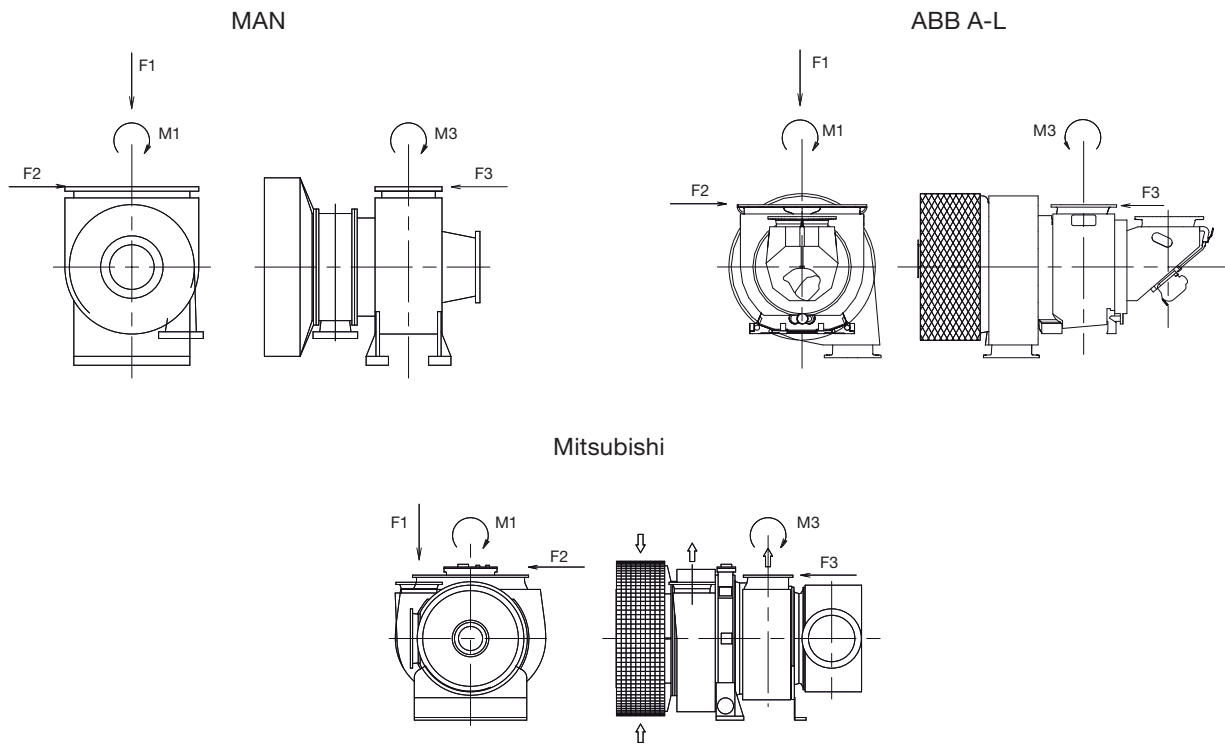

078 38 48-6.2.2

Fig. 15.06.03: Forces and moments on the turbochargers' exhaust gas outlet flange

Table 15.06.04 indicates the maximum permissible forces (F1, F2 and F3) and moments (M1 and M3), on the exhaust gas outlet flange of the turbo-charger(s). Reference is made to Fig. 15.06.03.

Turbocharger		M1	M3	F1	F2	F3
Make	Type	Nm	Nm	N	N	N
MAN	TCA77	4,100	8,200	10,900	10,900	5,400
	TCA88	4,500	9,100	12,000	12,000	5,900
ABB	A275	3,300	3,300	5,400	3,500	3,500
	A280	4,600	4,600	6,800	4,400	4,400
	A185 / A285	6,600	6,600	8,500	5,500	5,500
	A190	8,700	8,700	10,300	6,700	6,700
MHI	MET71	7,000	3,500	9,600	3,300	3,100
	MET83	9,800	4,900	11,700	4,100	3,700
	MET90	11,100	5,500	12,700	4,400	4,000

Table 15.06.04: The max. permissible forces and moments on the turbocharger's gas outlet flanges



### Diameter of Exhaust Gas Pipes

The exhaust gas pipe diameters listed in Table 15.07.02 are based on the exhaust gas flow capacity according to ISO ambient conditions and an exhaust gas temperature of 250 °C.

The exhaust gas velocities and mass flow listed apply to collector pipe D4. The table also lists the diameters of the corresponding exhaust gas pipes D0 for various numbers of turbochargers installed.

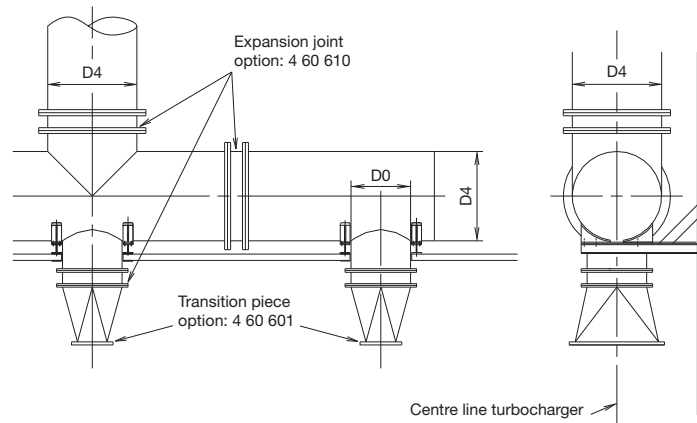

178 09 39-5.2

Fig. 15.07.01: Exhaust pipe system, with turbocharger located on exhaust side of engine

Gas velocity				Exhaust gas pipe diameters			
35 m/s	40 m/s	45 m/s	50 m/s	D0			D4
Gas mass flow				2 T/C	3 T/C	4 T/C	D4
kg/s	kg/s	kg/s	kg/s	[DN]	[DN]	[DN]	
74.2	84.8	95.4	106.0	1,400	1,150	1,000	2,000
81.8	93.5	105.2	116.9	1,500	1,200	1,050	2,100
89.8	102.6	115.5	128.3	1,600	1,300	1,100	2,200
98.1	112.2	126.2	140.2	1,600	1,300	1,150	2,300
106.9	122.1	137.4	152.7	1,700	1,400	1,200	2,400
116.0	132.5	149.1	165.6	1,800	1,400	1,300	2,500
125.4	143.3	161.2	179.2	1,800	1,500	1,300	2,600
135.2	154.6	173.9	193.2	N.A.	1,600	1,400	2,700
145.5	166.2	187.0	207.8	N.A.	1,600	1,400	2,800
156.0	178.3	200.6	222.9	N.A.	1,700	1,500	2,900
167.0	190.8	214.7	238.5	N.A.	1,700	1,500	3,000
178.3	203.8	229.2	254.7	N.A.	1,800	1,600	3,100
190.0	217.1	244.3	271.4	N.A.	1,800	1,600	3,200

Table 15.07.02: Exhaust gas pipe diameters and exhaust gas mass flow at various velocities



**MAN B&W**

---

# Engine Control System

16

---

**MAN Diesel**



## Engine Control System ME

The Engine Control System (ECS) for the ME engine is prepared for conventional remote control, having an interface to the Bridge Control system and the Local Operating Panel (LOP).

A Multi-Purpose Controller (MPC) is applied as control unit for specific tasks described below: ACU, CCU, CWCU, ECU, SCU and EICU. Except for the CCU, the control units are all built on the same identical piece of hardware and differ only in the software installed. For the CCU on ME and ME-C only, a downsized and cost-optimised controller is applied, the MPC10.

The layout of the Engine Control System is shown in Figs. 16.01.01a and b, the mechanical-hydraulic system is shown in Figs. 16.01.02a and b, and the pneumatic system, shown in Fig. 16.01.03.

The ME system has a high level of redundancy. It has been a requirement to its design that no single failure related to the system may cause the engine to stop. In most cases, a single failure will not affect the performance or power availability, or only partly do so by activating a slow down.

It should be noted that any controller could be replaced without stopping the engine, which will revert to normal operation immediately after the replacement of the defective unit.

### Main Operating Panel

Two redundant main operating panel (MOP) screens are available for the engineer to carry out engine commands, adjust the engine parameters, select the running modes, and observe the status of the control system. Both MOP screens are located in the Engine Control Room (ECR), one serving as back-up unit in case of failure or to be used simultaneously, if preferred.

Both MOP screens consist of a marine approved Personal Computer with a touch screen and pointing device as shown in Fig. 5.16.02.

### Engine Control Unit

For redundancy purposes, the control system comprises two engine control units (ECU) operating in parallel and performing the same task, one being a hot stand-by for the other. If one of the ECUs fail, the other unit will take over the control without any interruption.

The ECUs perform such tasks as:

- Speed governor functions, start/stop sequences, timing of fuel injection, timing of exhaust valve activation, timing of starting valves, etc.
- Continuous running control of auxiliary functions handled by the ACUs
- Alternative running modes and programs.

### Cylinder Control Unit

The control system includes one cylinder control unit (CCU) per cylinder. The CCU controls the Fuel Injection and exhaust Valve Activation (FIVA) and the Starting Air Valves (SAV), in accordance with the commands received from the ECU.

All the CCUs are identical, and in the event of a failure of the CCU for one cylinder only this cylinder will automatically be cut out of operation.

### Auxiliary Control Unit

The control of the auxiliary equipment on the engine is normally divided among three auxiliary control units (ACU) so that, in the event of a failure of one unit, there is sufficient redundancy to permit continuous operation of the engine.

The ACUs perform the control of the auxiliary blowers, the control of the electrically and engine driven hydraulic oil pumps of the Hydraulic Power Supply (HPS) unit.



**Cooling Water Control Unit**

On engines with load dependent cylinder liner (LDCL) cooling water system, a cooling water control unit (CWCU) controls the liner circulation string temperature by means of a three-way valve.

**Scavenge Air Control Unit**

The scavenge air control unit (SCU) controls the scavenge air pressure on engines with advanced scavenge air systems like exhaust gas bypass (EGB) with on/off or variable valve, waste heat recovery system (WHRS) and turbocharger with variable turbine inlet area (VT) technology.

For part- and low-load optimised engines with EGB variable bypass regulation valve, Economiser Engine Control (EEC) is available as an option in order to optimise the steam production versus SFOC, option: 4 65 342.

**Engine Interface Control Unit**

The two engine interface control units (EICU) perform such tasks as interface with the surrounding control systems, see Fig. 16.01.01a and b. The two EICU units operate in parallel and ensures redundancy for mission critical interfaces.

The EICUs are located either in the Engine Control Room (recommended) or in the engine room.

In the basic execution, the EICUs are a placed in the Cabinet for EICUs, EoD: 4 65 601.

**Control Network**

The MOP, the backup MOP and the MPCs are interconnected by means of the redundant Control Networks, A and B respectively.

The maximum length of Control Network cabling between the furthest units on the engine and in the Engine Control Room (an EICU or a MOP) is 230 meter.

Should the layout of the ship make longer Control Network cabling necessary, a Control Network Repeater must be inserted to amplify the signals and divide the cable into segments no longer than 230 meter. For instance, where the Engine Control Room and the engine room are located far apart. The connection of the two MOPs to the control network is shown in Fig. 5.16.01.

**Power Supply for Engine Control System**

The Engine Control System requires two separate power supplies with battery backup, power supply A and B.

The ME-ECS power supplies must be separated from other DC systems, i.e. only ME-ECS components must be connected to the supplies.

Power supply A	
System	IT (Floating), DC system w. individually isolated outputs
Voltage	Input 100-240V AC, 45-65 Hz, output 24V DC
Protection	Input over current, output over current, output high/low voltage
Alarms as potential free contacts	AC power, UPS battery mode, Batteries not available (fuse fail)

Power supply B	
System	IT (Floating), DC system w. individually isolated outputs
Voltage	Input 110-240 VAC, output 24V DC
Protection	Input over current, output over current, output high/low voltage
Alarms as potential free contacts	AC power, UPS battery mode, Batteries not available (fuse fail)

High/Low voltage protection may be integrated in the DC/DC converter functionality or implemented separately. The output voltage must be in the range 18-31V DC.





### **Local Operating Panel**

In normal operating the engine can be controlled from either the bridge or from the engine control room.

Alternatively, the local operating panel (LOP) can be activated. This redundant control is to be considered as a substitute for the previous Engine Side Control console mounted directly onto the MC engine.

The LOP is as standard placed on the engine.

From the LOP, the basic functions are available, such as starting, engine speed control, stopping, reversing, and the most important engine data are displayed.

### **Hydraulic Power Supply**

The purpose of the hydraulic power supply (HPS) unit is to deliver the necessary high pressure hydraulic oil flow to the Hydraulic Cylinder Units (HCU) on the engine at the required pressure (approx. 300 bar) during start-up as well as in normal service.

In case of the STANDARD mechanically driven HPS unit, at start, one of the two electrically driven start-up pumps is activated. The start-up pump is stopped 25 seconds after the engine reaches 15% speed.

The multiple pump configuration with standby pumps ensures redundancy with regard to the hydraulic power supply. The control of the engine driven pumps and electrical pumps are divided between the three ACUs.

The high pressure pipes between the HPS unit and the HCU are of the double-walled type, having a leak detector (210 bar system only). Emergency running is possible using the outer pipe as pressure containment for the high pressure oil supply.

The sizes and capacities of the HPS unit depend on the engine type. Further details about the HPS and the lubricating oil/hydraulic oil system can be found in Chapter 8.



### Engine Control System Layout with Cabinet for EICU

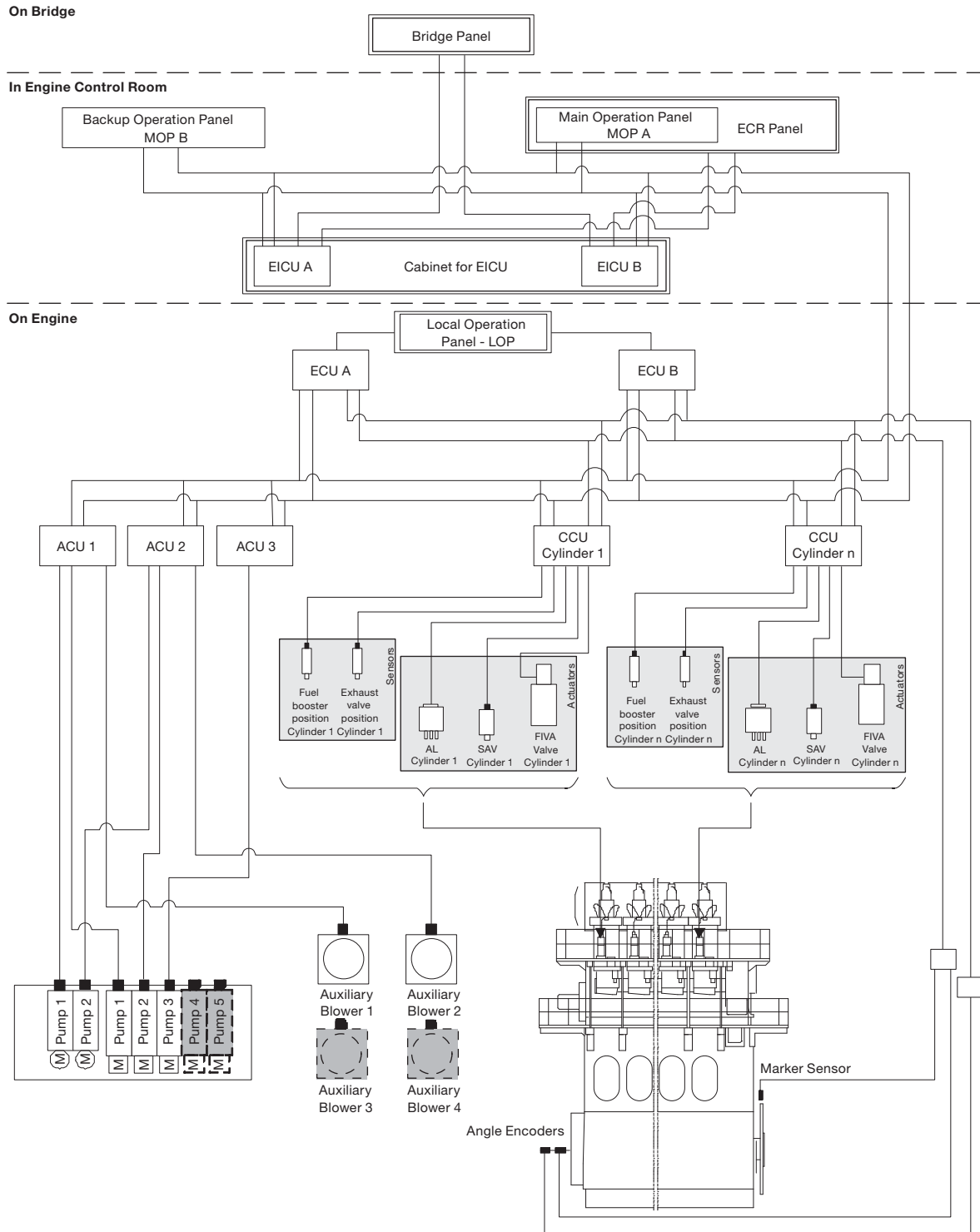

178 61 91-2.1

Fig. 16.01.01a: Engine Control System layout with cabinet for EICU for mounting in ECR or on engine, EoD: 4 65 601



### Engine Control System Layout with Common Control Cabinet

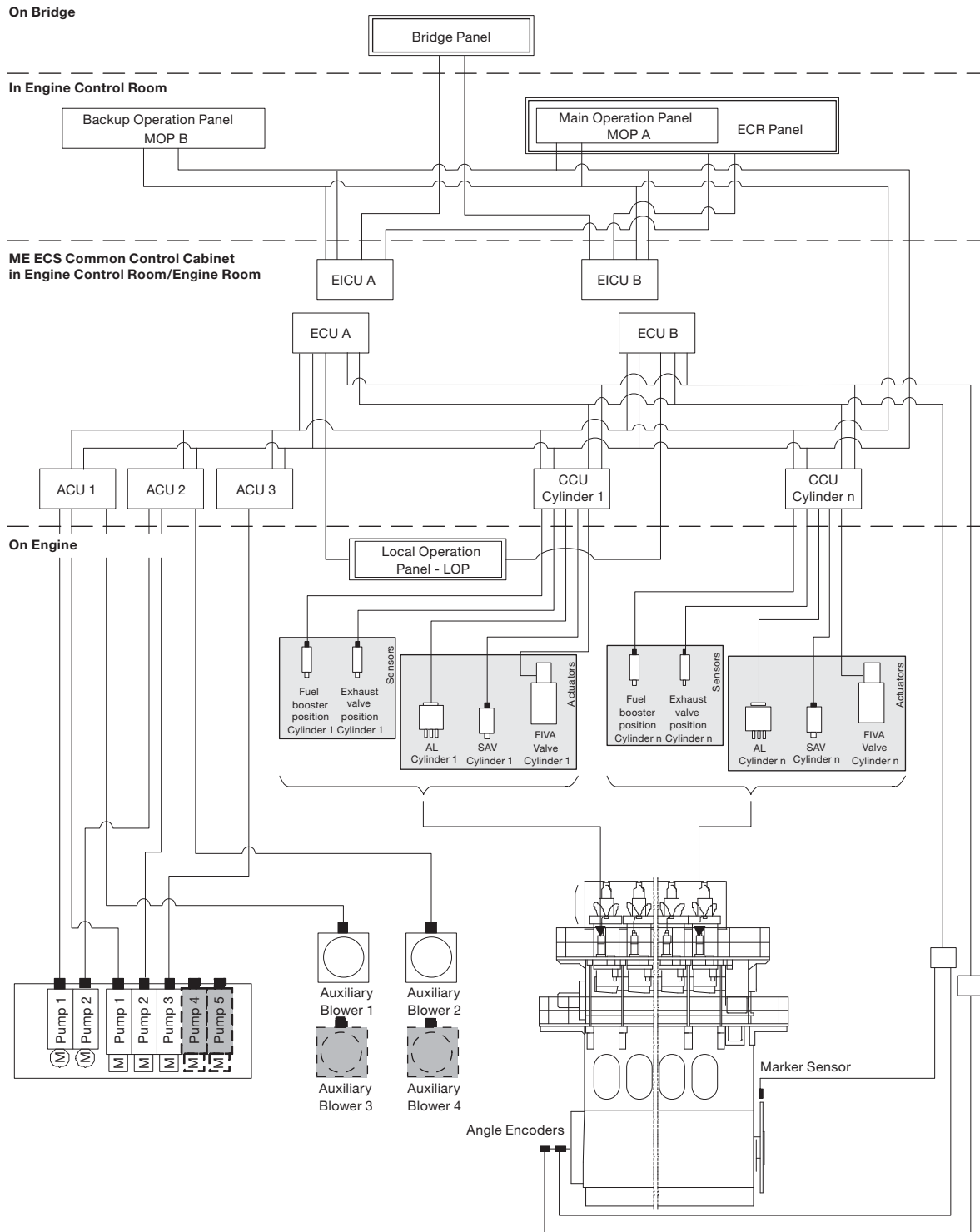

178 61 76-9.1

Fig. 16.01.01b: Engine Control System layout with ECS Common Control Cabinet for mounting in ECR or on engine, option: 4 65 602



### Mechanical-hydraulic System with Mechanically Driven HPS

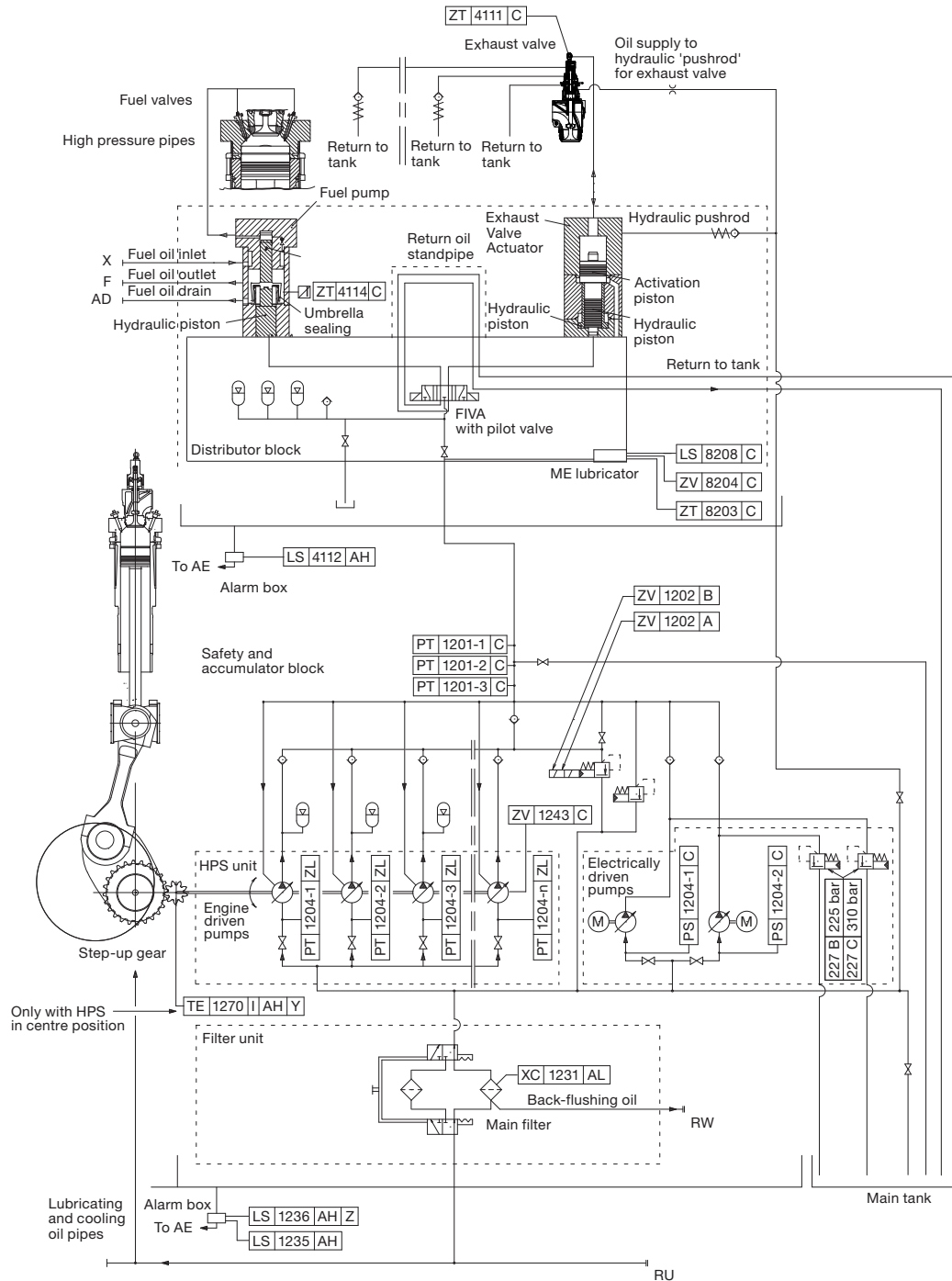

The letters refer to list of 'Counterflanges'  
 Th item No. refer to 'Guidance Values Automation'

515 75 30-9.5.2

Fig. 16.01.02a: Mechanical-hydraulic System with mechanically driven Hydraulic Power Supply, 300 bar, common supply



### Mechanical-hydraulic System with Electrically Driven HPS

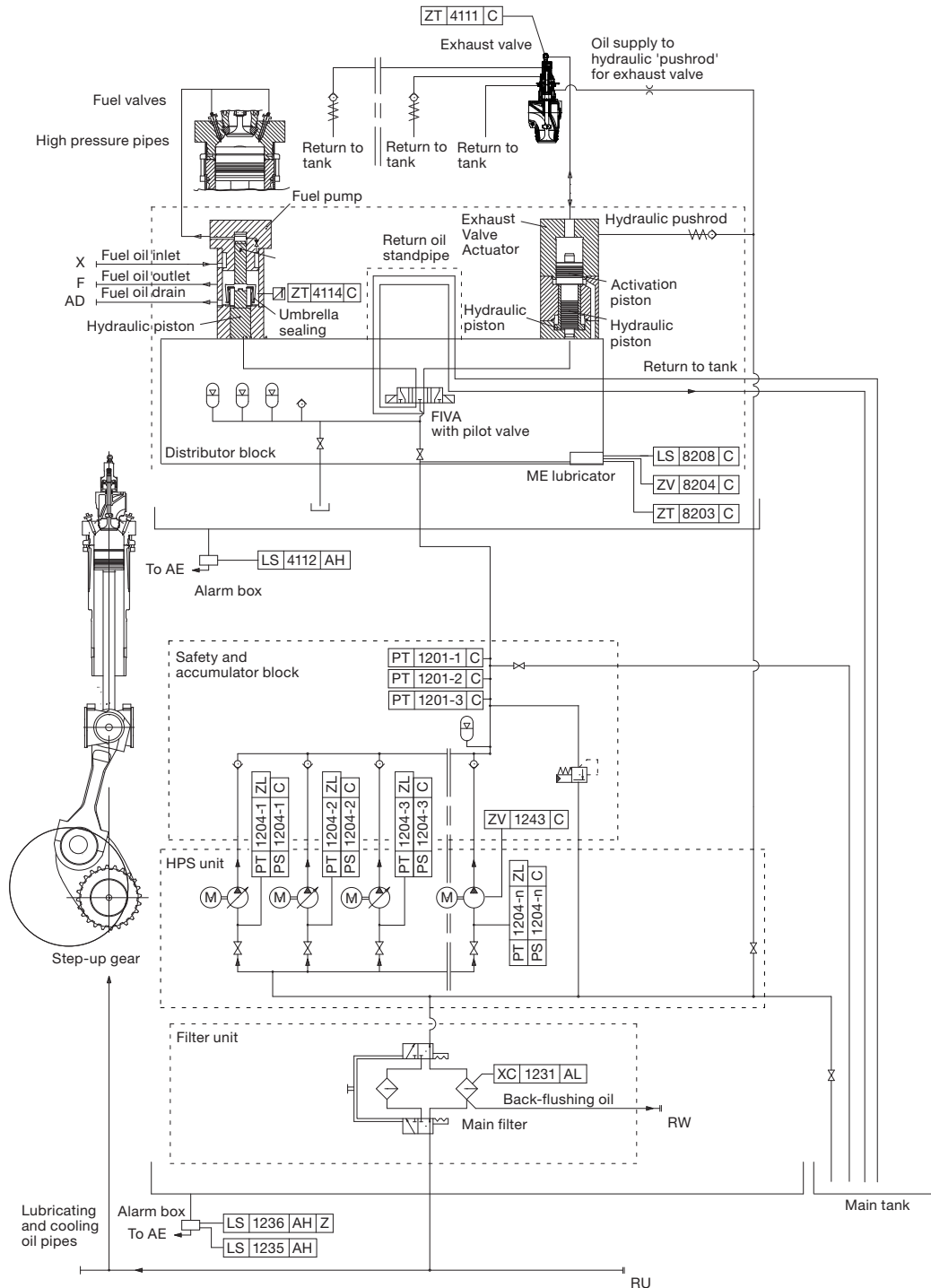

The letters refer to list of 'Counterflanges'  
 Th item No. refer to 'Guidance Values Automation'

515 75 49-1.1.1

Fig. 16.01.02b: Mechanical-hydraulic System with electrically driven Hydraulic Power Supply, 300 bar, common supply. Example from S90/80ME-C engine



## Engine Control System Interface to Surrounding Systems

To support the navigator, the vessels are equipped with a ship control system, which includes subsystems to supervise and protect the main propulsion engine.

### Alarm system

The alarm system has no direct effect on the ECS. The alarm alerts the operator of an abnormal condition.

The alarm system is an independent system, in general covering more than the main engine itself, and its task is to monitor the service condition and to activate the alarms if a normal service limit is exceeded.

The signals from the alarm sensors can be used for the slow down function as well as for remote indication.

### Slow down system

Some of the signals given by the sensors of the alarm system are used for the 'Slow down request' signal to the ECS of the main engine.

### Safety system

The engine safety system is an independent system with its respective sensors on the main engine, fulfilling the requirements of the respective classification society and MAN Diesel & Turbo.

If a critical value is reached for one of the measuring points, the input signal from the safety system must cause either a cancellable or a non-cancellable shut down signal to the ECS.

For the safety system, combined shut down and slow down panels approved by MAN Diesel & Turbo are available. The following options are listed in the Extent of Delivery:

4 75 631 Lyngsø Marine

4 75 632 Kongsberg Maritime

4 75 633 Nabtesco

4 75 636 Mitsui Zosen Systems Research.

Where separate shut down and slow down panels are installed, only panels approved by MAN Diesel & Turbo must be used.

In any case, the remote control system and the safety system (shut down and slow down panel) must be compatible.

### Telegraph system

This system enables the navigator to transfer the commands of engine speed and direction of rotation from the Bridge, the engine control room or the Local Operating Panel (LOP), and it provides signals for speed setting and stop to the ECS.

The engine control room and the LOP are provided with combined telegraph and speed setting units.



### Remote Control system

The remote control system normally has two alternative control stations:

- the bridge control
- the engine control room control.

The remote control system is to be delivered by a supplier approved by MAN Diesel & Turbo.

Bridge control systems from suppliers approved by MAN Diesel & Turbo are available. The Extent of Delivery lists the following options:

- for Fixed Pitch propeller plants, e.g.:
  - 4 95 703 Lyngsø Marine
  - 4 95 704 Mitsui Zosen Systems Research
  - 4 95 705 Nabtesco
  - 4 95 715 Kongsberg Maritime
- and for Controllable Pitch propeller plants, e.g.:
  - 4 95 701 Lyngsø Marine
  - 4 95 716 Kongsberg Maritime
  - 4 95 719 MAN Alphatronic.

### Power Management System

The system handles the supply of electrical power onboard, i. e. the starting and stopping of the generating sets as well as the activation / deactivation of the main engine Shaft Generator (SG), if fitted.

The normal function involves starting, synchronising, phasing-in, transfer of electrical load and stopping of the generators based on the electrical load of the grid on board.

The activation / deactivation of the SG is to be done within the engine speed range which fulfils the specified limits of the electrical frequency.

### Auxiliary equipment system

The input signals for 'Auxiliary system ready' are given partly through the Remote Control system based on the status for:

- fuel oil system
- lube oil system
- cooling water systems

and partly from the ECS itself:

- turning gear disengaged
- main starting valve 'open'
- control air valve for sealing air 'open'
- control air valve for air spring 'open'
- auxiliary blowers running
- hydraulic power supply ready.

### Monitoring systems

In addition to the PMI Auto-tuning system, which is part of the ME engine installation, CoCoS-EDS can be used for in-depth monitoring of the engine.

A description of the systems can be found in Chapter 18 of this Project Guide.

### Instrumentation

Chapter 18 in the Project Guide for the specific engine type includes lists of instrumentation for:

- The CoCoS-EDS system
- The class requirements and MAN Diesel & Turbo's requirements for alarms, slow down and shut down for Unattended Machinery Spaces.



### Pneumatic Manoeuvring Diagram

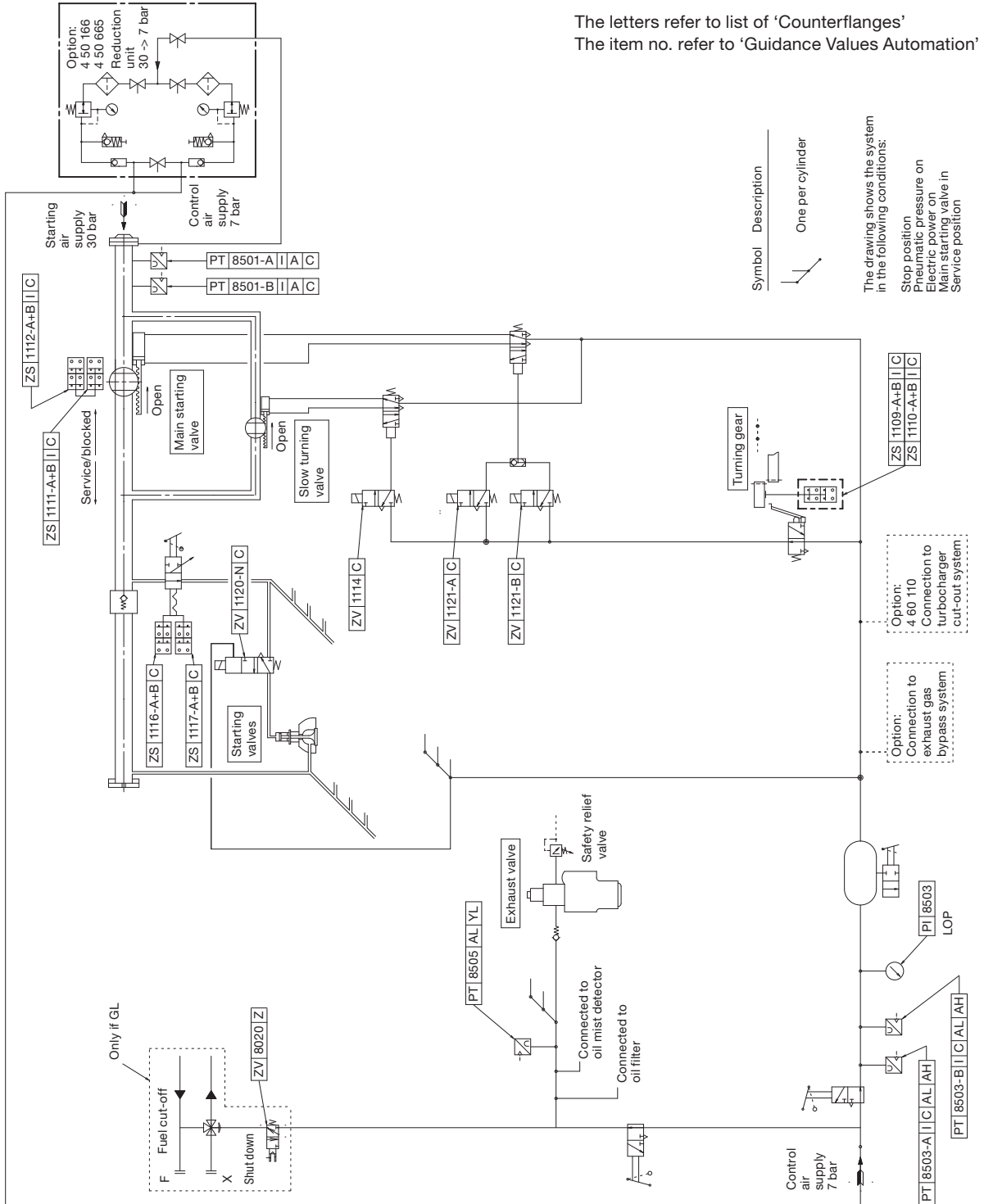

507 96 33-3.7.0

Fig. 16.01.03: Pneumatic Manoeuvring Diagram





**MAN B&W**

---

---

## Vibration Aspects

17

---

---

**MAN Diesel**



### Vibration Aspects

The vibration characteristics of the two-stroke low speed diesel engines can for practical purposes be split up into four categories, and if the adequate countermeasures are considered from the early project stage, the influence of the excitation sources can be minimised or fully compensated.

In general, the marine diesel engine may influence the hull with the following:

- External unbalanced moments
  - These can be classified as unbalanced 1st and 2nd order external moments, which need to be considered only for certain cylinder numbers
- Guide force moments
- Axial vibrations in the shaft system
- Torsional vibrations in the shaft system.

The external unbalanced moments and guide force moments are illustrated in Fig. 17.01.01.

In the following, a brief description is given of their origin and of the proper countermeasures needed to render them harmless.

#### External unbalanced moments

The inertia forces originating from the unbalanced rotating and reciprocating masses of the engine create unbalanced external moments although the external forces are zero.

Of these moments, the 1st order (one cycle per revolution) and the 2nd order (two cycles per revolution) need to be considered for engines with a low number of cylinders. On 7-cylinder engines, also the 4th order external moment may have to be examined. The inertia forces on engines with more than 6 cylinders tend, more or less, to neutralise themselves.

Countermeasures have to be taken if hull resonance occurs in the operating speed range, and if the vibration level leads to higher accelerations and/or velocities than the guidance values given by international standards or recommendations (for instance related to special agreement between shipowner and shipyard). The natural frequency of the hull depends on the hull's rigidity and distribution of masses, whereas the vibration level at resonance depends mainly on the magnitude of the external moment and the engine's position in relation to the vibration nodes of the ship.

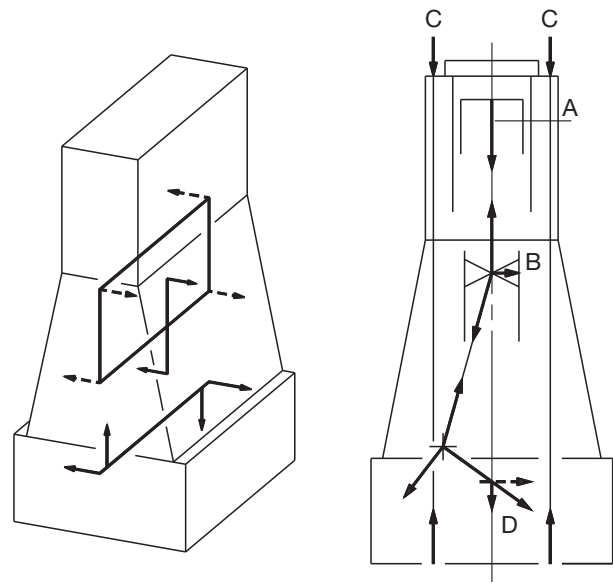

- A – Combustion pressure
- B – Guide force
- C – Staybolt force
- D – Main bearing force



1st order moment vertical 1 cycle/rev.  
2nd order moment, vertical 2 cycle/rev.



1st order moment, horizontal  
1 cycle/rev.



Guide force moment,  
H transverse Z cycles/rev.  
Z is 1 or 2 times number of cylinder

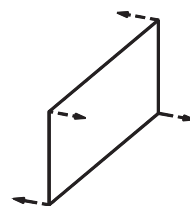

Guide force moment,  
X transverse Z cycles/rev.  
Z = 1, 2, 3 ... 11, 12, 14

178 06 82-8.2

Fig. 17.01.01: External unbalanced moments and guide force moments



## 2nd Order Moments on 5 and 6-cylinder Engines

The 2nd order moment acts only in the vertical direction. Precautions need only to be considered for 5 and 6-cylinder engines in general.

Resonance with the 2nd order moment may occur in the event of hull vibrations with more than 3 nodes. Contrary to the calculation of natural frequency with 2 and 3 nodes, the calculation of the 4 and 5-node natural frequencies for the hull is a rather comprehensive procedure and often not very accurate, despite advanced calculation methods.

A 2nd order moment compensator comprises two counter-rotating masses running at twice the engine speed.

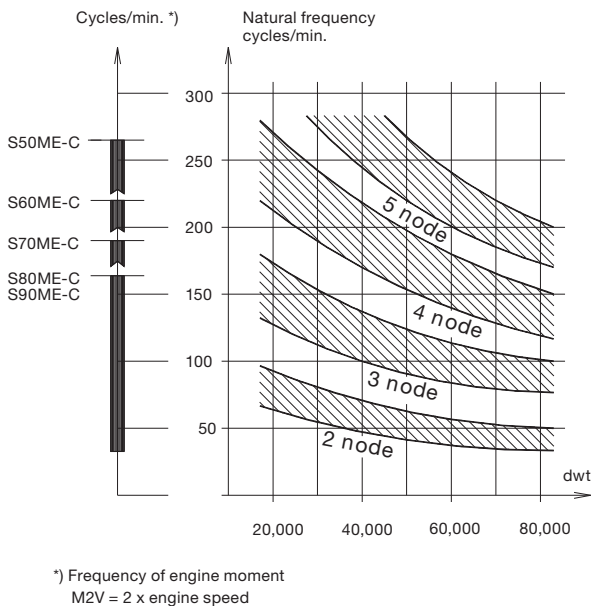

178 60 91-7.0

Fig. 17.02.01: Statistics of vertical hull vibrations in tankers and bulk carriers

### Compensator solutions

Several solutions are available to cope with the 2nd order moment, as shown in Fig. 17.03.02, out of which the most cost efficient one can be chosen in the individual case, e.g.:

- 1) No compensators, if considered unnecessary on the basis of natural frequency, nodal point and size of the 2nd order moment.
- 2) A compensator mounted on the aft end of the engine, driven by chain, option: 4 31 203.
- 3) A compensator mounted on the fore end, driven from the crankshaft through a separate chain drive, option: 4 31 213.

As standard, the compensators reduce the external 2nd order moment to a level as for a 7-cylinder engine or less.

Briefly speaking, solution 1) is applicable if the node is located far from the engine, or the engine is positioned more or less between nodes. Solution 2) or 3) should be considered where one of the engine ends is positioned in a node or close to it, since a compensator is inefficient in a node or close to it and therefore superfluous.

### Determine the need

A decision regarding the vibrational aspects and the possible use of compensators must be taken at the contract stage. If no experience is available from sister ships, which would be the best basis for deciding whether compensators are necessary or not, it is advisable to make calculations to determine which of the solutions should be applied.

**Preparation for compensators**

If compensator(s) are initially omitted, the engine can be delivered prepared for compensators to be fitted on engine fore end later on, but the decision to prepare or not must be taken at the contract stage, option: 4 31 212. Measurements taken during the sea trial, or later in service and with fully loaded ship, will be able to show if compensator(s) have to be fitted at all.

If no calculations are available at the contract stage, we advise to make preparations for the fitting of a compensator in the steering compartment, see Section 17.03.

**Basic design regarding compensators**

For 5 and 6-cylinder engines with mechanically driven HPS, the basic design regarding 2nd order moment compensators is:

- With compensator aft, EoD: 4 31 203
- Prepared for compensator fore, EoD: 4 31 212

For 5 and 6-cylinder engines with electrically driven HPS, the basic design regarding 2nd order moment compensators is:

- With MAN B&W external electrically driven moment compensator, RotComp, EoD: 4 31 255
- Prepared for compensator fore, EoD: 4 31 212

The available options are listed in the Extent of Delivery.

**1st Order Moments on 4-cylinder Engines**

This section is not applicable.



## Electrically Driven Moment Compensator

If it is decided not to use chain driven moment compensators and, furthermore, not to prepare the main engine for compensators to be fitted later, another solution can be used, if annoying 2nd order vibrations should occur: An external electrically driven moment compensator can neutralise the excitation, synchronised to the correct phase relative to the external force or moment.

This type of compensator needs an extra seating fitted, preferably, in the steering gear room where vibratory deflections are largest and the effect of the compensator will therefore be greatest.

The electrically driven compensator will not give rise to distorting stresses in the hull, but it is more expensive than the engine-mounted compensators. It does, however, offer several advantages over the engine mounted solutions:

- When placed in the steering gear room, the compensator is not as sensitive to the positioning of the node as the compensators 2) and 3) mentioned in Section 17.02.
- The decision whether or not to install compensators can be taken at a much later stage of a project, since no special version of the engine structure has to be ordered for the installation.
- No preparation for a later installation nor an extra chain drive for the compensator on the fore end of the engine is required. This saves the cost of such preparation, often left unused.
- Compensators could be retrofit, even on ships in service, and also be applied to engines with a higher number of cylinders than is normally considered relevant, if found necessary.
- The compensator only needs to be active at speeds critical for the hull girder vibration. Thus, it may be activated or deactivated at specified speeds automatically or manually.
- Combinations with and without moment compensators are not required in torsional and axial vibration calculations, since the electrically driven moment compensator is not part of the mass-elastic system of the crankshaft.

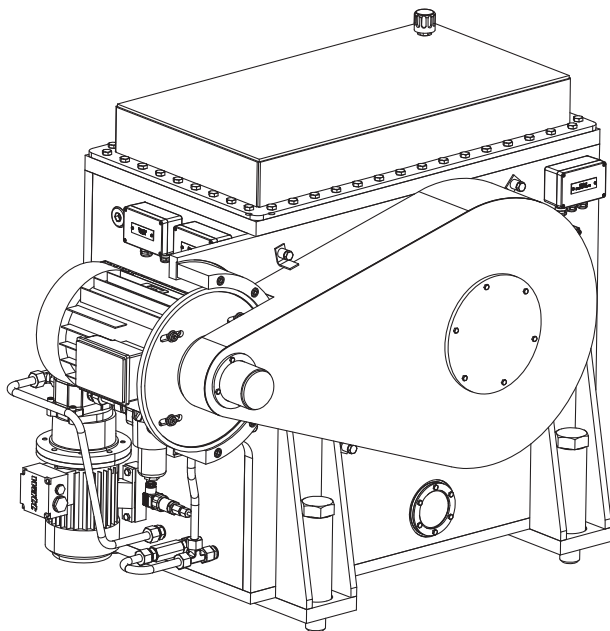

178 57 45-6.0

Fig. 17.03.01: MAN B&W external electrically driven moment compensator, RotComp, option: 4 31 255

Furthermore, by using the compensator as a vibration exciter a ship's vibration pattern can easily be identified without having the engine running, e.g. on newbuildings at an advanced stage of construction. If it is verified that a ship does not need the compensator, it can be removed and re-used on another ship.

It is a condition for the application of the rotating force moment compensator that no annoying longitudinal hull girder vibration modes are excited. Based on our present knowledge, and confirmed by actual vibration measurements onboard a ship, we do not expect such problems.

### Balancing other forces and moments

Further to compensating 2nd order moments, electrically driven balancers are also available for balancing other forces and moments. The available options are listed in the Extent of Delivery.



Moment compensator  
Aft end, option: 4 31 203

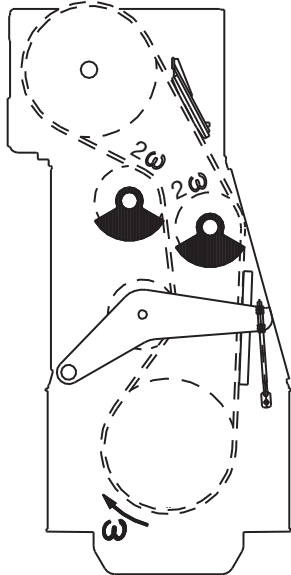

Moment compensator  
Fore end, option: 4 31 213

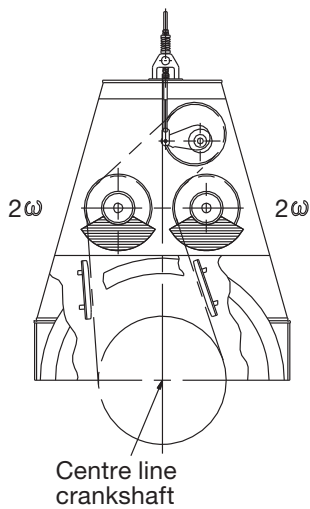

3 and 4-node vertical hull girder mode

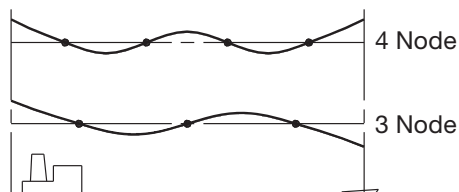

Compensating moment  
 $F_{2C} \times L_{node}$   
outbalances  $M_{2V}$

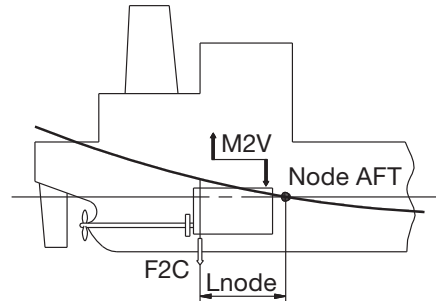

Moment from compensator  
 $M_{2C}$  reduces  $M_{2V}$

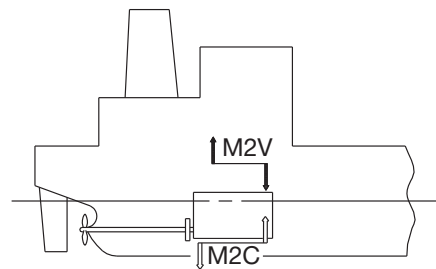

Electrically driven moment compensator

Compensating moment  
 $F_D \times L_{node}$   
outbalances  $M_{2V}$

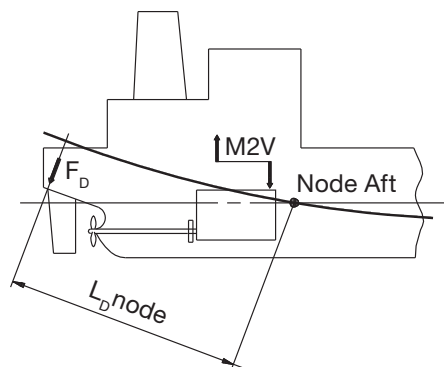

178 27 10-4.2

Fig. 17.03.02: Compensation of 2nd order vertical external moments



### Guide Force Moments

The so-called guide force moments are caused by the transverse reaction forces acting on the crossheads due to the connecting rod/crankshaft mechanism. These moments may excite engine vibrations, moving the engine top athwartships and causing a rocking (excited by H-moment) or twisting (excited by X-moment) movement of the engine as illustrated in Fig. 17.05.01.

The guide force moments corresponding to the MCR rating ( $L_r$ ) are stated in Table 17.07.01.

#### Top bracing

The guide force moments are harmless except when resonance vibrations occur in the engine/double bottom system.

As this system is very difficult to calculate with the necessary accuracy, MAN Diesel & Turbo strongly recommend, as standard, that top bracing is installed between the engine's upper platform brackets and the casing side.

The vibration level on the engine when installed in the vessel must comply with MAN Diesel & Turbo vibration limits as stated in Fig. 17.05.02.

We recommend using the hydraulic top bracing which allow adjustment to the loading conditions of the ship. Mechanical top bracings with stiff connections are available on request.

With both types of top bracing, the above-mentioned natural frequency will increase to a level where resonance will occur above the normal engine speed. Details of the top bracings are shown in Chapter 05.

#### Definition of Guide Force Moments

Over the years it has been discussed how to define the guide force moments. Especially now that complete FEM-models are made to predict hull/engine interaction, the proper definition of these moments has become increasingly important.

#### H-type Guide Force Moment ( $M_H$ )

Each cylinder unit produces a force couple consisting of:

1. A force at crankshaft level
2. Another force at crosshead guide level. The position of the force changes over one revolution as the guide shoe reciprocates on the guide.

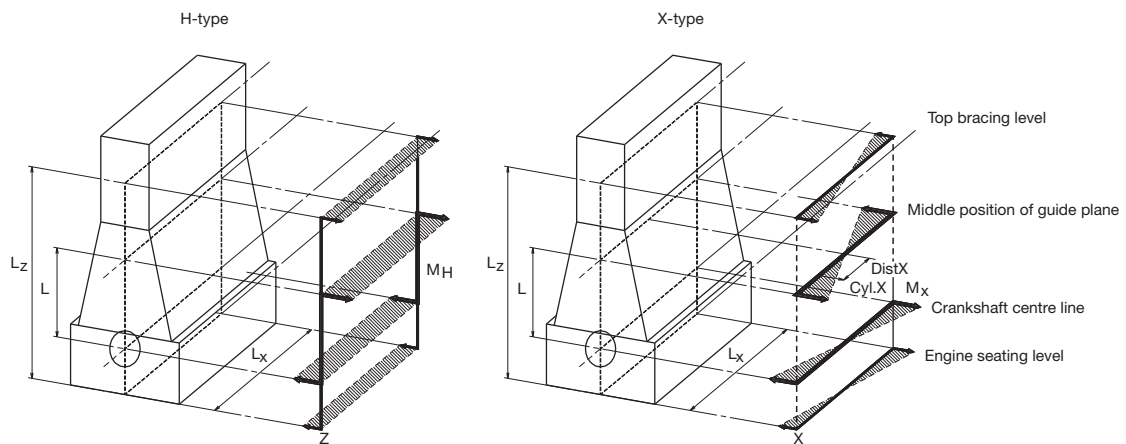

178 06 81-6.4

Fig. 17.05.01: H-type and X-type guide force moments



As the deflection shape for the H-type is equal for each cylinder, the N<sup>th</sup> order H-type guide force moment for an N-cylinder engine with regular firing order is:

$$N \times M_{H(\text{one cylinder})}$$

For modelling purposes, the size of the forces in the force couple is:

$$\text{Force} = M_H/L \text{ [kN]}$$

where L is the distance between crankshaft level and the middle position of the crosshead guide (i.e. the length of the connecting rod).

As the interaction between engine and hull is at the engine seating and the top bracing positions, this force couple may alternatively be applied in those positions with a vertical distance of (L<sub>z</sub>). Then the force can be calculated as:

$$\text{Force}_z = M_H/L_z \text{ [kN]}$$

Any other vertical distance may be applied so as to accommodate the actual hull (FEM) model.

The force couple may be distributed at any number of points in the longitudinal direction. A reasonable way of dividing the couple is by the number of top bracing and then applying the forces at those points.

$$\text{Force}_{z, \text{ one point}} = \text{Force}_{z, \text{ total}}/N_{\text{top bracing, total}} \text{ [kN]}$$

### X-type Guide Force Moment (M<sub>x</sub>)

The X-type guide force moment is calculated based on the same force couple as described above. However, as the deflection shape is twisting the engine, each cylinder unit does not contribute with an equal amount. The centre units do not contribute very much whereas the units at each end contributes much.

A so-called 'Bi-moment' can be calculated (Fig. 17.05.01):

$$\text{'Bi-moment'} = \sum [\text{force-couple}(\text{cyl.X}) \times \text{distX}] \text{ in kNm}^2$$

The X-type guide force moment is then defined as:

$$M_x = \text{'Bi-Moment'}/L \text{ kNm}$$

For modelling purpose, the size of the four (4) forces can be calculated:

$$\text{Force} = M_x/L_x \text{ [kN]}$$

where:

L<sub>x</sub> is the horizontal length between 'force points'.

Similar to the situation for the H-type guide force moment, the forces may be applied in positions suitable for the FEM model of the hull. Thus the forces may be referred to another vertical level L<sub>z</sub> above the crankshaft centre line. These forces can be calculated as follows:

$$\text{Force}_{z, \text{ one point}} = \frac{M_x \times L}{L_x \times L_x} \text{ [kN]}$$

In order to calculate the forces, it is necessary to know the lengths of the connecting rods = L, which are:

Engine Type	L in mm
K98ME6/7	3,220
K98ME-C6/7	3,090
G95ME-C9/-GI	3,720
S90ME-C9/10/-GI	3,600
S90ME-C8/-GI	3,270
K90ME-C6	3,159
G80ME-C9/-GI	3,720
S80ME-C9/-GI	3,450
S80ME-C7/8/-GI	3,280
K80ME-C9	2,975
K80ME-C6	2,920
G70ME-C9/-GI	3,256
S70ME-C7/8/-GI	2,870
L70ME-C7/8/-GI	2,660
S65ME-C8/-GI	2,730
G60ME-C9/-GI	2,790
S60ME-C7/8/-GI	2,460
L60ME-C8	2,280
S50ME-C7/8/-GI	2,050





Vibration Limits Valid for Single Order Harmonics

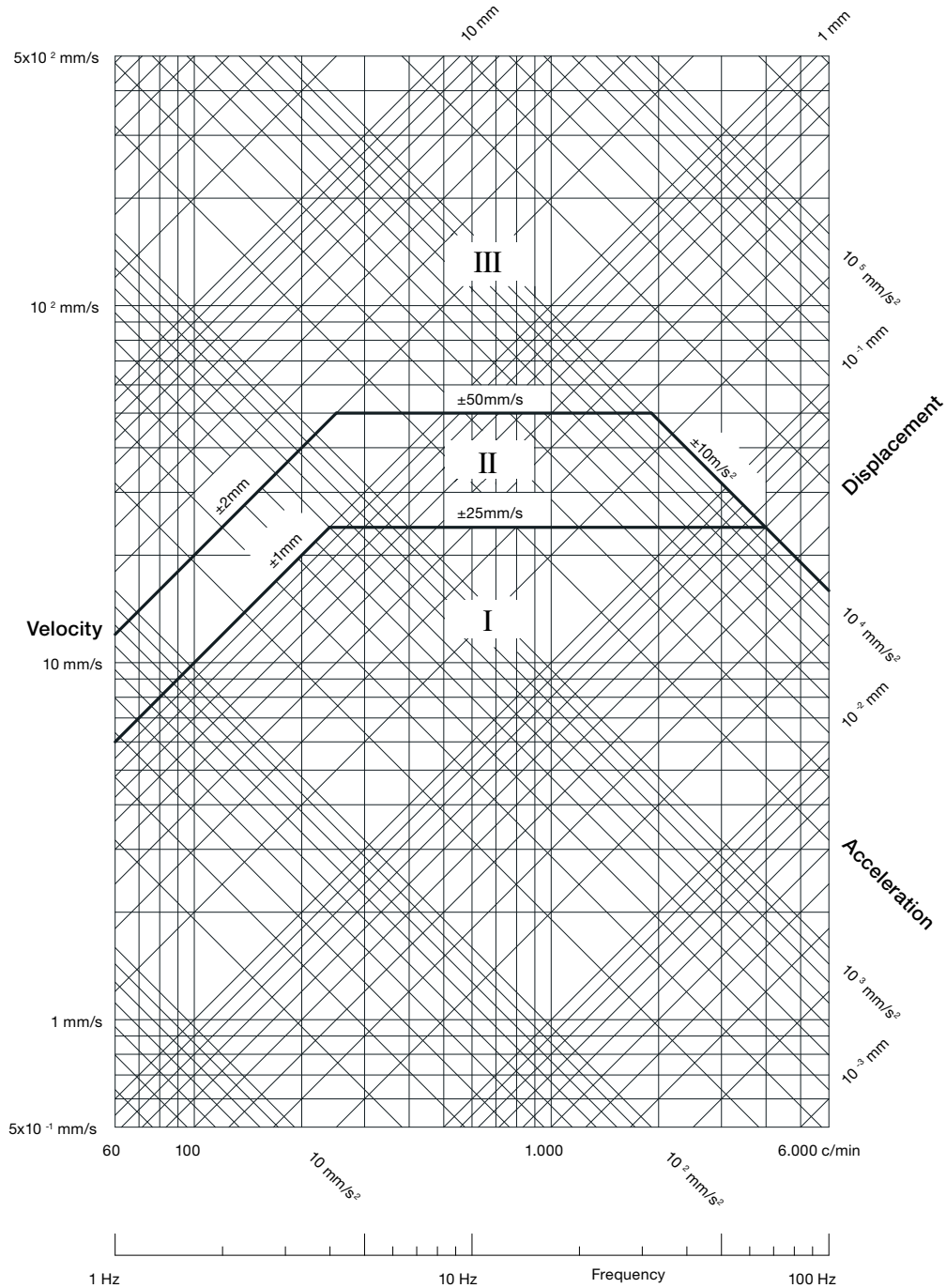

- Zone I: Acceptable
- Zone II: Vibration will not damage the main engine, however, under adverse conditions, annoying/harmful vibration responses may appear in the connected structures
- Zone III: Not acceptable

078 81 27-6.1

Fig.17.05.02: Vibration limits



## Axial Vibrations

When the crank throw is loaded by the gas pressure through the connecting rod mechanism, the arms of the crank throw deflect in the axial direction of the crankshaft, exciting axial vibrations. Through the thrust bearing, the system is connected to the ship's hull.

Generally, only zero-node axial vibrations are of interest. Thus the effect of the additional bending stresses in the crankshaft and possible vibrations of the ship's structure due to the reaction force in the thrust bearing are to be considered.

An axial damper is fitted as standard on all engines, minimising the effects of the axial vibrations, EoD: 4 31 111.

## Torsional Vibrations

The reciprocating and rotating masses of the engine including the crankshaft, the thrust shaft, the intermediate shaft(s), the propeller shaft and the propeller are for calculation purposes considered a system of rotating masses (inertias) interconnected by torsional springs. The gas pressure of the engine acts through the connecting rod mechanism with a varying torque on each crank throw, exciting torsional vibration in the system with different frequencies.

In general, only torsional vibrations with one and two nodes need to be considered. The main critical order, causing the largest extra stresses in the shaft line, is normally the vibration with order equal to the number of cylinders, i.e., six cycles per revolution on a six cylinder engine. This resonance is positioned at the engine speed corresponding to the natural torsional frequency divided by the number of cylinders.

The torsional vibration conditions may, for certain installations require a torsional vibration damper, option: 4 31 105.

Plants with 11 or 12-cylinder engines type 98-80 require a torsional vibration damper.

Based on our statistics, this need **may arise** for the following types of installation:

- Plants with controllable pitch propeller
- Plants with unusual shafting layout and for special owner/yard requirements
- Plants with 8-cylinder engines.

The so-called QPT (Quick Passage of a barred speed range Technique), is an alternative to a torsional vibration damper, on a plant equipped with a controllable pitch propeller. The QPT could be implemented in the governor in order to limit the vibratory stresses during the passage of the barred speed range.

The application of the QPT, option: 4 31 108, has to be decided by the engine maker and MAN Diesel & Turbo based on final torsional vibration calculations.

Six-cylinder engines, require special attention. On account of the heavy excitation, the natural frequency of the system with one-node vibration should be situated away from the normal operating speed range, to avoid its effect. This can be achieved by changing the masses and/or the stiffness of the system so as to give a much higher, or much lower, natural frequency, called undercritical or overcritical running, respectively.

Owing to the very large variety of possible shafting arrangements that may be used in combination with a specific engine, only detailed torsional vibration calculations of the specific plant can determine whether or not a torsional vibration damper is necessary.

## Undercritical running

The natural frequency of the one-node vibration is so adjusted that resonance with the main critical order occurs about 35-45% above the engine speed at specified MCR.

Such undercritical conditions can be realised by choosing a rigid shaft system, leading to a relatively high natural frequency.

The characteristics of an undercritical system are normally:

- Relatively short shafting system
- Probably no tuning wheel
- Turning wheel with relatively low inertia
- Large diameters of shafting, enabling the use of shafting material with a moderate ultimate tensile strength, but requiring careful shaft alignment, (due to relatively high bending stiffness)
- Without barred speed range.



## Critical Running

When running undercritical, significant varying torque at MCR conditions of about 100-150% of the mean torque is to be expected.

This torque (propeller torsional amplitude) induces a significant varying propeller thrust which, under adverse conditions, might excite annoying longitudinal vibrations on engine/double bottom and/or deck house.

The yard should be aware of this and ensure that the complete aft body structure of the ship, including the double bottom in the engine room, is designed to be able to cope with the described phenomena.

### Overcritical running

The natural frequency of the one-node vibration is so adjusted that resonance with the main critical order occurs about 30-70% below the engine speed at specified MCR. Such overcritical conditions can be realised by choosing an elastic shaft system, leading to a relatively low natural frequency.

The characteristics of overcritical conditions are:

- Tuning wheel may be necessary on crankshaft fore end
- Turning wheel with relatively high inertia
- Shafts with relatively small diameters, requiring shafting material with a relatively high ultimate tensile strength
- With barred speed range, EoD: 4 07 015, of about  $\pm 10\%$  with respect to the critical engine speed.

Torsional vibrations in overcritical conditions may, in special cases, have to be eliminated by the use of a torsional vibration damper.

Overcritical layout is normally applied for engines with more than four cylinders.

Please note:

*We do not include any tuning wheel or torsional vibration damper in the standard scope of supply, as the proper countermeasure has to be found after torsional vibration calculations for the specific plant, and after the decision has been taken if and where a barred speed range might be acceptable.*

For further information about vibration aspects, please refer to our publications:

*An Introduction to Vibration Aspects*

*Vibration Characteristics of Two-stroke Engines*

The publications are available at [www.marine.man.eu](http://www.marine.man.eu) → 'Two-Stroke' → 'Technical Papers'.



**MAN B&W**

---

---

# Monitoring Systems and Instrumentation

18

---

---

**MAN Diesel**



## Monitoring Systems and Instrumentation

The Engine Control System (ECS) can be supported by the PMI system and the CoCoS-EDS (Computer Controlled Surveillance-Engine Diagnostics System).

The optional CoCoS-EDS Full version measures the main parameters of the engine and makes an evaluation of the general engine condition, indicating the countermeasures to be taken. This ensures that the engine performance is kept within the prescribed limits throughout the engine's lifetime.

In its basic design, the ME engine instrumentation consists of:

- Engine Control System
- Shut-down sensors, EoD: 4 75 124
- PMI Auto-tuning system, EoD: 4 75 216
- CoCoS-EDS ME Basic, EoD: 4 09 658
- Sensors for alarm, slow down and remote indication according to the classification society's and MAN Diesel & Turbo's requirements for UMS, EoD: 4 75 127, see Section 18.04.

The optional extras are:

- CoCoS-EDS Full version (AMS interface), option: 4 09 660.

Sensors for CoCoS-EDS Full version can be ordered, if required, as option: 4 75 129. They are listed in Section 18.03.

All instruments are identified by a combination of symbols and a position number as shown in Section 18.07.



### PMI Auto-tuning System

The PMI Auto-tuning system is an advanced cylinder pressure monitoring system that automatically adjusts combustion pressures for optimum performance. This system is specified as standard, EoD: 4 75 216, and completely replaces the PMI Offline system.

The auto-tuning concept is based on the online measurement of the combustion chamber pressures from permanently mounted sensors.

The engine control system constantly monitors and compares the measured combustion pressures to a reference value. As such, the control system automatically adjusts the fuel injection

and valve timing to reduce the deviation between measured and reference values. This, in turn, facilitates the optimal combustion pressures for the next firing. Thus, the system ensures that the engine is running at the desired maximum pressure, p(max). Furthermore, the operator can press a button on the touch panel display, causing the system to automatically balance the engine.

Pressure measurements are presented in real time in measurement curves on a PC, thereby eliminating the need for manual measurements. Key performance values are continuously calculated and displayed in tabular form. These measurements may be stored for later analysis or transferred to CoCoS-EDS for further processing.

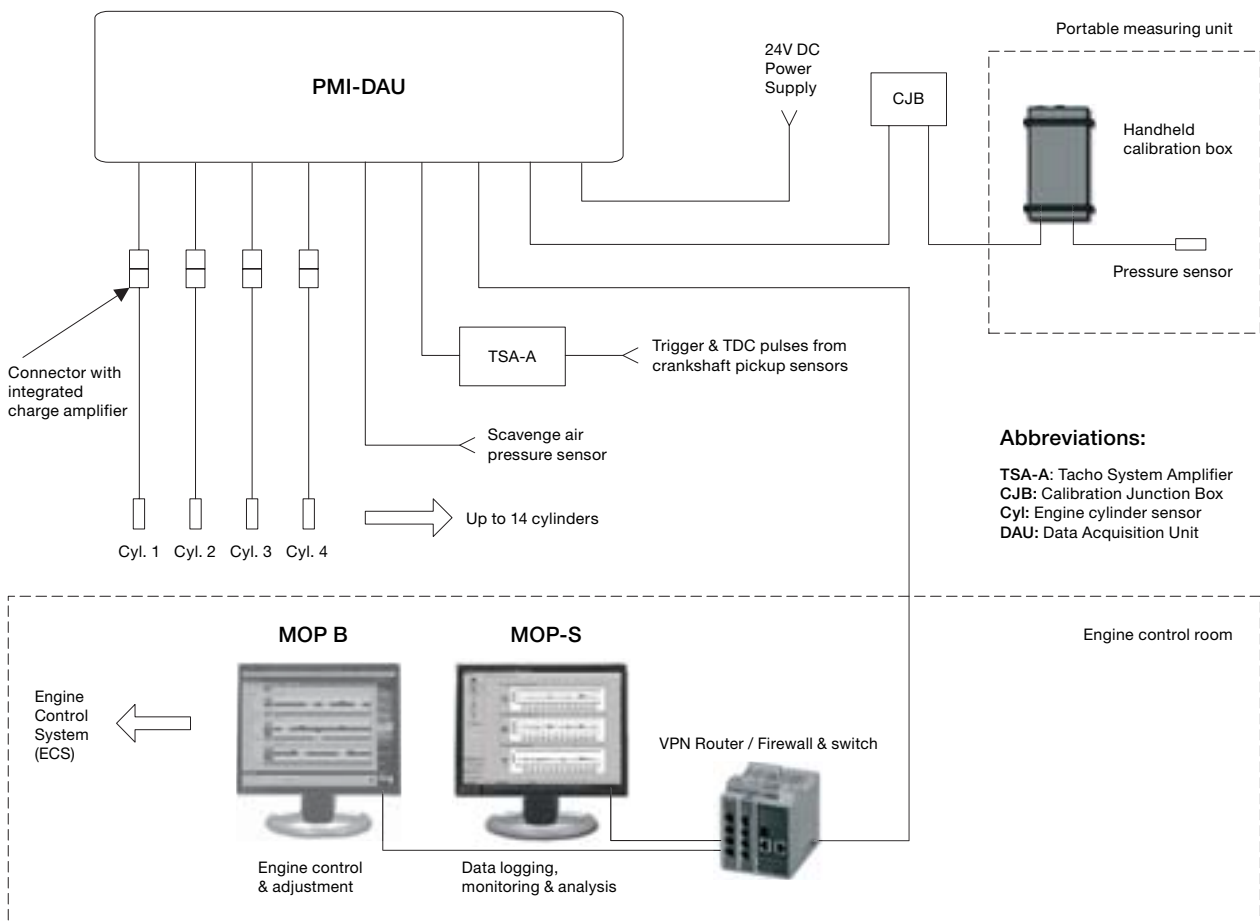

178 62 45-3.1

Fig. 18.02.01: PMI Auto-tuning system, EoD: 4 75 216



## Condition Monitoring System CoCoS-EDS

The Computer Controlled Surveillance system, CoCoS-EDS, is the condition monitoring system for MAN B&W engines from MAN Diesel & Turbo.

Two versions are available, CoCoS-EDS Full version and CoCoS-EDS ME basic. Both versions are run on the PMI/CoCoS PC located in the engine control room. The network connection is shown in Fig. 5.16.01.

### CoCoS-EDS Full version

CoCoS-EDS Full version (AMS interface), option: 4 09 660, assists in engine performance evaluation and provides detailed engine operation surveillance.

Key features are: online data logging, monitoring, trending and reporting.

The CoCoS-EDS Full version is recommended as an extension for the Engine Control System and the PMI System in order to obtain an easier, more versatile performance monitoring system.

For the CoCoS-EDS Full version additional sensors are required, option: 4 75 129. The sensors are listed in Table 18.03.01.

### CoCoS-EDS ME basic

All MAN B&W ME and ME-B engines are as standard specified with CoCoS-EDS ME basic, EoD: 4 09 658.

Key features are: data logging, monitoring, trending and reporting as for the Full version. However, the AMS interface and reference curves for diagnostic functions are not included.

CoCoS-EDS ME basic provides a software interface to the ME/ME-B Engine Control System and the PMI system, no additional sensors are required.



## CoCoS-EDS Sensor List

Sensors required for the CoCoS-EDS Full version engine performance analysis, option: 4 75 129, see Table 18.03.01. All pressure gauges are measuring relative pressure, except for 'PT 8802 Ambient pressure'.

Sensor	Parameter name	No. of sensors	Recommended range	Resolution 3)	Remark
<b>Fuel oil system data</b>					
PT 8001	Inlet pressure	1	0 - 10 bar	0.1 bar	
TE 8005	Inlet temperature	1	0 - 200 °C	0.1 °C	
<b>Cooling water system</b>					
PT 8421	Pressure air cooler inlet	A/C	0 - 4 bar	0.1 bar	
TE 8422	Temperature air cooler inlet	1	0 - 100 °C	0.1 °C	
TE 8423	Temperature air cooler outlet	A/C	0 - 100 °C	0.1 °C	
PDT 8424	dP cooling water across air cooler	A/C	0 - 800 mbar	0.1 mbar	
<b>Scavenging air system</b>					
PT 8601	Scavenge air receiver pressure	Rec.	0 - 4 bar	1 mbar	1)
TE 8605	Scavenge air cooler air inlet temperature	A/C	0 - 200 °C	0.1 °C	
PDT 8606	dP air across scavenge air cooler	A/C	0 - 100 mbar	0.1 mbar	
TE 8608	Scavenge air cooler air outlet temperature	A/C	0 - 100 °C	0.1 °C	Optional if one T/C
TE 8609	Scavenge air receiver temperature	Rec.	0 - 100 °C	0.1 °C	
TE 8612	T/C air intake temperature	T/C	0 - 100 °C	0.1 °C	
<b>Exhaust gas system</b>					
TC 8701	Exhaust gas temperature at turbine inlet	T/C	0 - 600 °C	0.1 °C	
TC 8702	Exhaust gas temperature after exhaust valve	Cyl.	0 - 600 °C	0.1 °C	
PT 8706	Exhaust gas receiver pressure	Rec.	0 - 4 bar	0.01 bar	
TC 8707	Exhaust gas temperature at turbine outlet	T/C	0 - 600 °C	0.1 °C	
PT 8708	Turbine back pressure	T/C	0 - 100 mbar	0.1 mbar	
<b>General data</b>					
ZT 8801	Turbocharger speed	T/C	rpm	1 rpm	
PT 8802	Ambient pressure	1	900 - 1,100 mbar	1 mbar	Absolute!
ZT 4020	Engine speed	1	rpm	0.1 rpm	1)
XC 8810	Governor index (relative)	1	%	0.1 %	1)
-	Power take off/in from main engine shaft (PTO/PTI)	1	kW	1 kW	With option installed
<b>Pressure measurement</b>					
XC1401	Mean Indicated Pressure, MIP	Cyl.	bar	0.01 bar	2)
XC1402	Maximum Pressure, Pmax	Cyl.	bar	0.1 bar	2)
XC1403	Compression Pressure, Pcomp	Cyl.	bar	0.1 bar	2)
-	PMI online engine speed	Cyl.	rpm	0.1 rpm	2)

The 'No. of sensors' depends on number of cylinders (Cyl.), turbochargers (T/C), air receivers (Rec.) and air coolers (A/C) as marked.

1) Signal acquired from Engine Control System (ECS)

2) In case of MAN Diesel & Turbo PMI system: signal from PMI system. Other MIP systems: signal from manual input

3) Resolution of signals transferred to CoCoS-EDS (from the Alarm Monitoring System).

Table 18.03.01: List of sensors for CoCoS-EDS Full version





## Alarm – Slow Down and Shut Down System

The shut down system must be electrically separated from other systems by using independent sensors, or sensors common to the alarm system and the monitoring system but with galvanically separated electrical circuits, i.e. one sensor with two sets of electrically independent terminals. The list of sensors are shown in Table 18.04.04.

### Basic safety system design and supply

The basic safety sensors for a MAN B&W engine are designed for Unattended Machinery Space (UMS) and comprises:

- the temperature sensors and pressure sensors that are specified in the 'MAN Diesel' column for shut down in Table 18.04.04.

These sensors are included in the basic Extent of Delivery, EoD: 4 75 124.

### Alarm and slow down system design and supply

The basic alarm and slow down sensors for a MAN B&W engine are designed for Unattended Machinery Space (UMS) and comprises:

- the sensors for alarm and slow down.

These sensors are included in the basic Extent of Delivery, EoD: 4 75 127.

The shut down and slow down panels can be ordered as options: 4 75 630, 4 75 614 or 4 75 615 whereas the alarm panel is yard's supply, as it normally includes several other alarms than those for the main engine.

For practical reasons, the sensors for the engine itself are normally delivered from the engine supplier, so they can be wired to terminal boxes on the engine.

The number and position of the terminal boxes depends on the degree of dismantling specified in the Dispatch Pattern for the transportation of the engine based on the lifting capacities available at the engine maker and at the yard.

### Alarm, slow down and remote indication sensors

The International Association of Classification Societies (IACS) indicates that a common sensor can be used for alarm, slow down and remote indication.

A general view of the alarm, slow down and shut down systems is shown in Fig. 18.04.01.

Tables 18.04.02 and 18.04.03 show the requirements by MAN Diesel & Turbo for alarm and slow down and for UMS by the classification societies (Class), as well as IACS' recommendations.

The number of sensors to be applied to a specific plant is the sum of requirements of the classification society, the Buyer and MAN Diesel & Turbo.

If further analogue sensors are required, they can be ordered as option: 4 75 128.

### Slow down functions

The slow down functions are designed to safeguard the engine components against overloading during normal service conditions and to keep the ship manoeuvrable if fault conditions occur.

The slow down sequence must be adapted to the actual plant parameters, such as for FPP or CPP, engine with or without shaft generator, and to the required operating mode.



### Electrical System, General Outline

The figure shows the concept approved by all classification societies.

One common power supply might be used, instead of the three indicated, provided that the systems are equipped with separate fuses.

The shut down panel and slow down panel can be combined for some makers.

The classification societies permit having common sensors for slow down, alarm and remote indication.

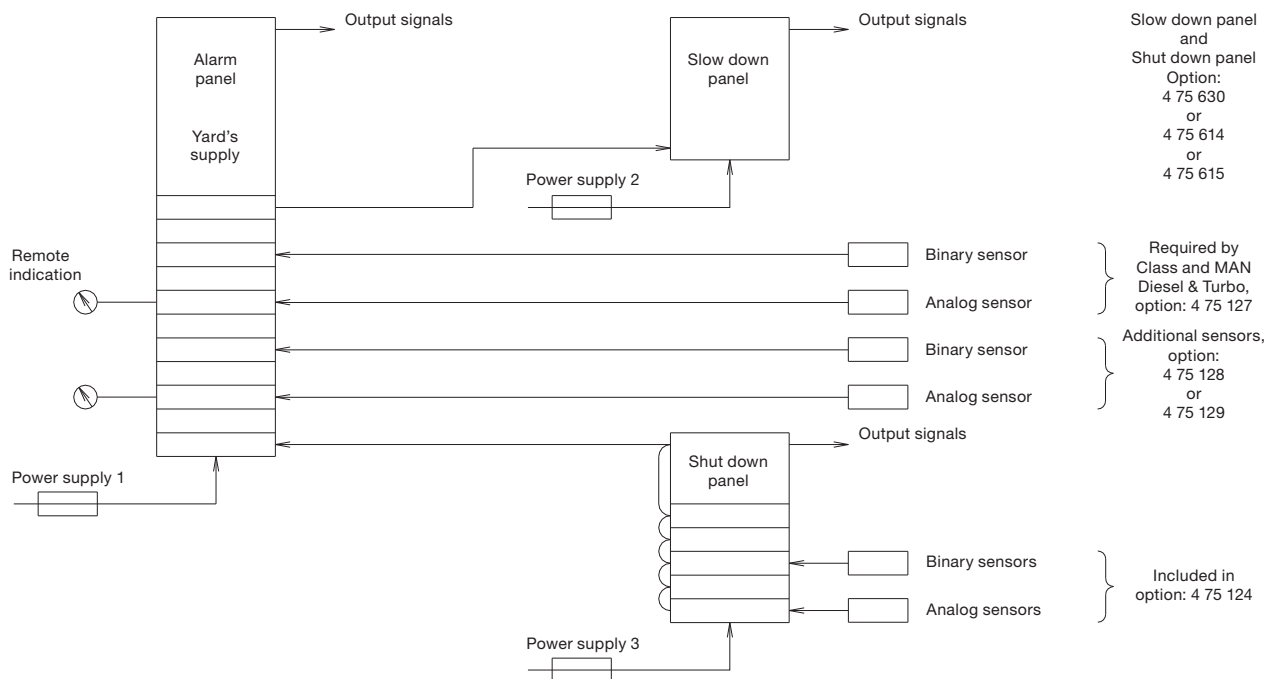

178 30 10-0.7

Fig. 18.04.01: Panels and sensors for alarm and safety systems



Alarms for UMS – Class and MAN Diesel & Turbo requirements

ABS	BV	CCS	DNV	GL	KR	LR	NK	RINA	RS	IACS	MAN Diesel	Sensor and function	Point of location
<b>Fuel oil</b>													
1	1	1	1	1	1	1	1	1	1	1	1	PT 8001 AL	Fuel oil, inlet engine
1	1	1	1	1	1	1	1	1	1	1	1	LS 8006 AH	Leakage from high pressure pipes
<b>Lubricating oil</b>													
1	1	1	1	1	1	1	1	1	1	1	1	TE 8106 AH	Thrust bearing segment
1	1	1	1	1	1	1	1	1	1	1	1	PT 8108 AL	Lubricating oil inlet to main engine
1	1	1	1	1	1	1	1	1	1	1	1	TE 8112 AH	Lubricating oil inlet to main engine
1	1	1	1	1	1		1	1	1	1	1	TE 8113 AH	Piston cooling oil outlet/cylinder
1	1	1	1	1	1		1	1	1	1	1	FS 8114 AL	Piston cooling oil outlet/cylinder
1	1	1		1	1	1		1	1	1	1	TE 8117 AH	Turbocharger lubricating oil outlet from turbocharger/turbocharger
												1 TE 8123 AH	Main bearing oil outlet temperature/main bearing (S40/35ME-B9 only)
												1 XC 8126 AH	Bearing wear (All types except S40/35ME-B9); sensor common to XC 8126/27
												1 XS 8127 A	Bearing wear detector failure (All types except S40/35ME-B)
		1		1		1	1					1 PDS 8140 AH	Lubricating oil differential pressure – cross filter
												1 XS 8150 AH	Water in lubricating oil; sensor common to XS 8150/51/52
												1 XS 8151 AH	Water in lubricating oil – too high
												1 XS 8152 A	Water in lubricating oil sensor not ready
<b>MAN B&amp;W Alpha Lubrication</b>													
												1 LS 8212 AL	Small box for heating element, low level

1 Indicates that the sensor is required.  
 The sensors in the MAN Diesel and relevant Class columns are included in the basic Extent of Delivery, EoD: 4 75 127.  
 The sensor identification codes and functions are listed in Table 18.07.01.  
 The tables are liable to change without notice, and are subject to latest Class requirements.

Table 18.04.02a: Alarm functions for UMS



Alarms for UMS – Class and MAN Diesel & Turbo requirements

ABS	BV	CCS	DNV	GL	KR	LR	NK	RINA	RS	IACS	MAN Diesel	Sensor and function	Point of location			
													<b>Hydraulic Power Supply</b>			
													1	XC 1231 A	Automatic main lube oil filter, failure (Boll & Kirch)	
													1	TE 1310 AH	Lubrication oil inlet (Only for ME/-GI with separate oil system to HPS installed)	
													<b>Cooling water</b>			
1	1	1	1	1	1	1	1	1	1	1	1	1	PT 8401 AL	Jacket cooling water inlet		
													1	PDT 8403 AL	Jacket cooling water across engine; to be calculated in alarm system from sensor no. 8402 and 8413 3)	
														1	PDT 8404 AL	Jacket cooling water across cylinder liners 2)
														1	PDT 8405 AL	Jacket cooling water across cylinder covers and exhaust valves 2)
														1	TE 8407 AL	Jacket cooling water inlet
1	1	1	1	1	1	1	1	1	1	1	1	1	TE 8408 AH	Jacket cooling water outlet, cylinder		
														1	TT 8410	Cylinder cover cooling water outlet, cylinder 2)
														1	PT 8413 I	Jacket cooling water outlet, common pipe
1	1	1		1	1	1	1	1	1	1	1	1	PT 8421 AL	Cooling water inlet air cooler		
														1	TE 8422 AH	Cooling water inlet air cooler/air cooler
													<b>Compressed air</b>			
1	1	1		1	1	1	1	1	1	1	1	1	PT 8501 AL	Starting air inlet to main starting valve		
1	1	1	1	1	1	1	1	1+	1	1	1	1	PT 8503 AL	Control air inlet and finished with engine		
														1	PT 8505 AL	Air inlet to air cylinder for exhaust valve
													<b>Scavenge air</b>			
														1	PS 8604 AL	Scavenge air, auxiliary blower, failure (Only ME-B)
	1	1		1								1	TE 8609 AH	Scavenge air receiver		
1	1	1	1	1	1	1	1	1	1	1	1	1	TE 8610 AH	Scavenge air box – fire alarm, cylinder/cylinder		
1	1	1		1	1	1	1	1	1	1	1	1	LS 8611 AH	Water mist catcher – water level		

1 Indicates that the sensor is required.  
 The sensors in the MAN Diesel and relevant Class columns are included in the basic Extent of Delivery, EoD: 4 75 127.  
 The sensor identification codes and functions are listed in Table 18.07.01.  
 The tables are liable to change without notice, and are subject to latest Class requirements.

- 2) Required only for engines with LDCL cooling water system
- 3) Not applicable for engines with LDCL cooling water system

- ☐ Select one of the alternatives
- + Alarm for high pressure, too
- ÷ Alarm for low pressure, too

Table 18.04.02b: Alarm functions for UMS



Alarms for UMS – Class and MAN Diesel & Turbo requirements

ABS	BV	CCS	DNV	GL	KR	LR	NK	RINA	RS	IACS	MAN Diesel	Sensor and function	Point of location
<b>Exhaust gas</b>													
1	1	1	1	1	1	(1)	1	1	1	1	1	TC 8701 AH	Exhaust gas before turbocharger/turbocharger
1	1		1		1	1	1	1	1	1	1	TC 8702 AH	Exhaust gas after exhaust valve, cylinder/cylinder
1	1	1	1	1	1	1	1	1	1	1	1	TC 8707 AH	Exhaust gas outlet turbocharger/turbocharger (Yard's supply)
<b>Miscellaneous</b>													
1	1	<input type="checkbox"/>	1	1	1	1	1	1	1	1	1	1	WT 8812 AH Axial vibration monitor 2)
												1	XS 8813 AH Oil mist in crankcase/cylinder; sensor common to XS 8813/14
	1											1	XS 8814 AL Oil mist detector failure
												1	XC 8816 I Shaftline earthing device
												1	TE 8820 AH Cylinder liner monitoring/cylinder 3)
<b>Engine Control System</b>													
1	1	1	1	1	1	1	1	1	1	1	1	XC 2201 A	Power failure
1	1		1	1		1	1	1	1	1	1	XC 2202 A	ME common failure
												1	XC 2202-A A ME common failure (ME-GI only)
												1	XC 2213 A Double-pipe HC alarm (ME-GI only)
<b>Power Supply Units to Alarm System</b>													
												1	XC 2901 A Low voltage ME power supply A
												1	XC 2902 A Low voltage ME power supply B
												1	XC 2903 A Earth failure ME power supply

1 Indicates that the sensor is required.

The sensors in the MAN Diesel and relevant Class columns are included in the basic Extent of Delivery, EoD: 4 75 127.

The sensor identification codes and functions are listed in Table 18.07.01.

The tables are liable to change without notice, and are subject to latest Class requirements.

(1) May be combined with TC 8702 AH where turbocharger is mounted directly on the exhaust manifold.

2) Required for: K-ME-C6/7 and K98ME6/7 engines with 11 and 14 cylinders incl. ME-GI variants.  
All ME-C9/10 and ME-B9 engines incl. ME-GI variants.  
All ME-C7/8 and ME-B8 engines with 5 and 6 cylinders incl. ME-GI variants.

3) Required for: K98ME/ME-C, S90ME-C, K90ME-C and K80ME-C9 engines incl. ME-GI variants.

Alarm for overheating of main, crank and crosshead bearings, option: 4 75 134.

Table 18.04.02c: Alarm functions for UMS



Slow down for UMS – Class and MAN Diesel & Turbo requirements

ABS	BV	CCS	DNV	GL	KR	LR	NK	RINA	RS	IACS	MAN Diesel	Sensor and function	Point of location			
1	1	1	1	1	1	1	1	1	1	1	1	TE 8106 YH	Thrust bearing segment			
1	1	1	1*	1	1	1	1	1	1	1	1	PT 8108 YL	Lubricating oil inlet to main engine			
				1		1						TE 8112 YH	Lubricating oil inlet to main engine			
1	1	1	1	1	1		1	1	1	1	1	TE 8113 YH	Piston cooling oil outlet/cylinder			
1	1	1	1	1	1		1	1	1	1	1	FS 8114 YL	Piston cooling oil outlet/cylinder			
												1	TE 8123 YH	Main bearing oil outlet temperature/main bearing (S40/35ME-B9 only)		
												1	XC 8126 YH	Bearing wear (All except S40/35ME-B9)		
1	<input type="checkbox"/>	<input type="checkbox"/>	1		1	<input type="checkbox"/>	1	1	1	1	1	1	PT 8401 YL	Jacket cooling water inlet		
													1	PDT 8403 YL	Jacket cooling water across engine (Not for LDCL)	
													1	PDT 8404	Jacket cooling water across cylinder liners (Only for YL LDCL)	
													1	PDT 8405	Jacket cooling water across cylinder covers and ex-haust valves (Only for LDCL)	
1	1	1	1	1	1	1	1	1	1	1	1	1	TE 8408 YH	Jacket cooling water outlet, cylinder/cylinder		
	1	<input type="checkbox"/>					<input type="checkbox"/>						1	TE 8609 YH	Scavenge air receiver	
1	1	<input type="checkbox"/>	1	1	1	1	<input type="checkbox"/>	1	1	1	1	1	1	TE 8610 YH	Scavenge air box fire-alarm, cylinder/cylinder	
		1	1										1	TC 8701 YH	Exhaust gas before turbocharger/turbocharger	
1	1		1	<input type="checkbox"/>	1	1	1	1	1	1	1	1	1	TC 8702 YH	Exhaust gas after exhaust valve, cylinder/cylinder	
			1	<input type="checkbox"/>										TC 8702 YH	Exhaust gas after exhaust valve, cylinder/cylinder, deviation from average	
														1	WT 8812 YH	Axial vibration monitor 2)
<input type="checkbox"/>	<input type="checkbox"/>	<input type="checkbox"/>	<input type="checkbox"/>		<input type="checkbox"/>	<input type="checkbox"/>	<input type="checkbox"/>	<input type="checkbox"/>	<input type="checkbox"/>	<input type="checkbox"/>	<input type="checkbox"/>	1	1	XS 8813 YH	Oil mist in crankcase/cylinder	
														1	XS/XT	Turbocharger overspeed (Only in case of VT TC, Waste Heat Recovery, Exhaust Gas Bypass, TC Cut-out)
														1	TE 1310 YH	Lubrication oil inlet (Only for ME/-GI with separate oil system to HPS installed)

1 Indicates that the sensor is required.

The sensors in the MAN Diesel and relevant Class columns are included in the basic Extent of Delivery, EoD: 4 75 127.

The sensor identification codes and functions are listed in Table 18.07.01.

The tables are liable to change without notice, and are subject to latest Class requirements.

2) Required for: K-ME-C6/7 and K98ME6/7 engines with 11 and 14 cylinders incl. ME-GI variants.

All ME-C9/10 and ME-B9 engines incl. ME-GI variants.

All ME-C7/8 and ME-B8 engines with 5 and 6 cylinders incl. ME-GI variants.

Select one of the alternatives

\* Or shut down

Or alarm for low flow

Or shut down

Or alarm for overheating of main, crank and crosshead bearings, option: 4 75 134.

See also Table 18.04.04: Shut down functions for AMS and UMS

Table 18.04.03: Slow down functions for UMS



Shut down for AMS and UMS – Class and MAN Diesel & Turbo requirements

ABS	BV	CCS	DNV	GL	KR	LR	NK	RINA	RS	IACS	MAN Diesel	Sensor and function	Point of location
1	1	1	1*	1	1	1	1	1	1	1	1	PS/PT 8109 Z	Lubricating oil inlet to main engine and thrust bearing
1	1	1	1*	1	1	1	1	1	1	1	1	ZT 4020 Z	Engine overspeed
1	1	1			1			1	1	1	1	TE/TS 8107 Z	Thrust bearing segment
				1								PS/PT 8402 Z	Jacket cooling water inlet
			<input type="checkbox"/>	<input type="checkbox"/>								XS 8813 Z	Oil mist in crankcase/cylinder

1 Indicates that the sensor is required.  
 The sensors in the MAN Diesel and relevant Class columns are included in the basic Extent of Delivery, EoD: 4 75 124.  
 The sensor identification codes and functions are listed in Table 18.07.01.  
 The tables are liable to change without notice, and are subject to latest Class requirements.

- Or alarm for overheating of main, crank and crosshead bearings, option: 4 75 134.  
See also Table 18.04.03: Slow down functions for UMS
- \* Or slow down

International Association of Classification Societies

The members of the International Association of Classification Societies, IACS, have agreed that the stated sensors are their common recommendation, apart from each Class' requirements.

The members of IACS are:

- ABS American Bureau of Shipping
- BV Bureau Veritas
- CCS China Classification Society
- CRS Croatian Register of Shipping
- DNV Det Norske Veritas
- GL Germanischer Lloyd
- IRS Indian Register of Shipping
- KR Korean Register
- LR Lloyd's Register
- NK Nippon Kaiji Kyokai
- PRS Croatian Register of Shipping
- RINA Registro Italiano Navale
- RS Russian Maritime Register of Shipping

Table 18.04.04: Shut down functions for AMS and UMS, option: 4 75 124



## Local Instruments

The basic local instrumentation on the engine, options: 4 70 119 comprises thermometers, pressure gauges and other indicators located on the piping or mounted on panels on the engine. The tables 18.05.01a, b and c list those as well as sensors for slow down, alarm and remote indication, option: 4 75 127.

Local instruments	Remote sensors	Point of location
<b>Thermometer, stem type</b>	<b>Temperature element/switch</b>	
		<b>Hydraulic power supply</b>
	TE 1270	HPS bearing temperature (Only ME/ME-C with HPS in centre position)
		<b>Fuel oil</b>
TI 8005	TE 8005	Fuel oil, inlet engine
		<b>Lubricating oil</b>
TI 8106	TE 8106	Thrust bearing segment
	TE/TS 8107	Thrust bearing segment
TI 8112	TE 8112	Lubricating oil inlet to main engine
TI 8113	TE 8113	Piston cooling oil outlet/cylinder
TI 8117	TE 8117	Lubricating oil outlet from turbocharger/turbocharger (depends on turbocharger design)
	TE 8123	Main bearing oil outlet temperature/main bearing (S40/35ME-B9 only)
		<b>Cylinder lubricating oil</b>
	TE 8202	Cylinder lubricating oil inlet
	TS 8213	Cylinder lubricating heating
		<b>High temperature cooling water, jacket cooling water</b>
TI 8407	TE 8407	Jacket cooling water inlet
TI 8408	TE 8408	Jacket cooling water outlet, cylinder/cylinder
TI 8409	TE 8409	Jacket cooling water outlet/turbocharger
TI 8410	TT 8410	Cylinder cover cooling water outlet, cylinder (Only for LDCL)
		<b>Low temperature cooling water, seawater or freshwater for central cooling</b>
TI 8422	TE 8422	Cooling water inlet, air cooler
TI 8423	TE 8423	Cooling water outlet, air cooler/air cooler
		<b>Scavenge air</b>
TI 8605	TE 8605	Scavenge air before air cooler/air cooler
TI 8608	TE 8608	Scavenge air after air cooler/air cooler
TI 8609	TE 8609	Scavenge air receiver
	TE 8610	Scavenge air box – fire alarm, cylinder/cylinder
<b>Thermometer, dial type</b>	<b>Thermo couple</b>	
		<b>Exhaust gas</b>
TI 8701	TC 8701	Exhaust gas before turbocharger/turbocharger
	TI/TC 8702	Exhaust gas after exhaust valve, cylinder/cylinder
	TC 8704	Exhaust gas inlet exhaust gas receiver
TI 8707	TC 8707	Exhaust gas outlet turbocharger

Table 18.05.01a: Local thermometers on engine, options 4 70 119, and remote indication sensors, option: 4 75 127





Local instruments	Remote sensors	Point of location
<b>Pressure gauge (manometer)</b>	<b>Pressure transmitter/switch</b>	
PI 8001	PT 8001	<b>Fuel oil</b> Fuel oil, inlet engine
PI 8103	PT 8103	<b>Lubricating oil</b> Lubricating oil inlet to turbocharger/turbocharger
PI 8108	PT 8108	Lubricating oil inlet to main engine
	PS/PT 8109	Lubricating oil inlet to main engine and thrust bearing
	PDS 8140	Lubricating oil differential pressure – cross filter
PI 8401	PT 8401	<b>High temperature jacket cooling water, jacket cooling water</b> Jacket cooling water inlet
	PS/PT 8402	Jacket cooling water inlet (Only Germanischer Lloyd)
	PDT 8403	Jacket cooling water across engine (or PT 8401 and PT 8413) (Not for LDCL)
	PDT 8404	Jacket cooling water across cylinder liners (Only for LDCL)
	PDT 8405	Jacket cooling water across cylinder covers and exhaust valves (Only for LDCL)
	PT 8413	Jacket cooling water outlet, common pipe
PI 8421	PT 8421	<b>Low temperature cooling water, seawater or freshwater for central cooling</b> Cooling water inlet, air cooler
PI 8501	PT 8501	<b>Compressed air</b> Starting air inlet to main starting valve
PI 8503	PT 8503	Control air inlet
	PT 8505	Air inlet to air cylinder for exhaust valve (Only ME-B)
PI 8601	PT 8601	<b>Scavenge air</b> Scavenge air receiver (PI 8601 instrument same as PI 8706)
PDI 8606	PDT 8606	Pressure drop of air across cooler/air cooler
	PDT 8607	Pressure drop across blower filter of turbocharger (ABB turbochargers only)
PI 8706		<b>Exhaust gas</b> Exhaust gas receiver/Exhaust gas outlet turbocharger
PI 8803		<b>Miscellaneous functions</b> Air inlet for dry cleaning of turbocharger
PI 8804		Water inlet for cleaning of turbocharger (Not applicable for MHI turbochargers)

Table 18.05.01b: Local pressure gauges on engine, options: 4 70 119, and remote indication sensors, option: 4 75 127



Local instruments	Remote sensors	Point of location
<b>Other indicators</b>	<b>Other transmitters/ switches</b>	
		<b>Hydraulic power supply</b>
	XC 1231	Automatic main lube oil filter, failure (Boll & Kirch)
	LS 1235	Leakage oil from hydraulic system
	LS 1236	Leakage oil from hydraulic system
		<b>Engine cylinder components</b>
	LS 4112	Leakage from hydraulic cylinder unit
		<b>Fuel oil</b>
	LS 8006	Leakage from high pressure pipes
		<b>Lubricating oil</b>
	FS 8114	Piston cooling oil outlet/cylinder
	XC 8126	Bearing wear (All types except S40/35ME-B9)
	XS 8127	Bearing wear detector failure (All types except S40-35ME-B9)
	XS 8150	Water in lubricating oil
	XS 8151	Water in lubricating oil – too high
	XS 8152	Water in lubricating oil sensor not ready
		<b>Cylinder lube oil</b>
	LS 8208	Level switch
	LS 8212	Small box for heating element, low level
		<b>Scavenge air</b>
	LS 8611	Water mist catcher – water level
		<b>Miscellaneous functions</b>
	ZT 8801 I	Turbocharger speed/turbocharger
WI 8812	WT 8812	Axial vibration monitor (For certain engines only, see note in Table 18.04.04) (WI 8812 instrument is part of the transmitter WT 8812)
	XS 8813	Oil mist in crankcase/cylinder
	XS 8814	Oil mist detector failure
	XC 8816	Shaftline earthing device
	XS/XT 8817	Turbocharger overspeed (Only in case of VT TC, Waste Heat Recovery, Exhaust Gas Bypass, TC Cut-out)

Table 18.05.01c: Other indicators on engine, options: 4 70 119, and remote indication sensors, option: 4 75 127



## Other Alarm Functions

### Drain Box for Fuel Oil Leakage Alarm

Any leakage from the fuel oil high pressure pipes of any cylinder is drained to a common drain box fitted with a level alarm. This is included in the basic design of MAN B&W engines.

### Bearing Condition Monitoring

Based on our experience, we decided in 1990 that all plants must include an oil mist detector specified by MAN Diesel & Turbo. Since then an Oil Mist Detector (OMD) and optionally some extent of Bearing Temperature Monitoring (BTM) equipment have made up the warning arrangements for prevention of crankcase explosions on two-stroke engines. Both warning systems are approved by the classification societies.

In order to achieve a response to damage faster than possible with Oil Mist Detection and Bearing Temperature Monitoring alone we introduce Bearing Wear Monitoring (BWM) systems. By monitoring the actual bearing wear continuously, mechanical damage to the crank-train bearings (main-, crank- and crosshead bearings) can be predicted in time to react and avoid damaging the journal and bearing housing.

If the oil supply to a main bearing fails, the bearing temperature will rise and in such a case a Bearing Temperature Monitoring system will trigger an alarm before wear actually takes place. For that reason the ultimate protection against severe bearing damage and the optimum way of providing early warning, is a combined bearing wear and temperature monitoring system.

For all types of error situations detected by the different bearing condition monitoring systems applies that in addition to damaging the components, in extreme cases, a risk of a crankcase explosion exists.

### Oil Mist Detector

The oil mist detector system constantly measures samples of the atmosphere in the crankcase compartments and registers the results on an optical measuring track, where the opacity (degree of haziness) is compared with the opacity of the atmospheric air. If an increased difference is recorded, a slow down is activated (a shut down in case of Germanischer Lloyd).

Furthermore, for shop trials only MAN Diesel & Turbo requires that the oil mist detector is connected to the shut down system.

For personnel safety, the oil mist detectors and related equipment are located on the manoeuvring side of the engine.

The following oil mist detectors are available:

4 75 162	Oil mist detector Graviner MK7. Make: Kidde Fire Protection
4 75 161	Oil mist detector Graviner MK6. Make: Kidde Fire Protection
4 75 163	Oil mist detector Visatron VN 215/93. Make: Schaller Automation
4 75 165	Oil mist detector QMI. Make: Quality Monitoring Instruments Ltd.
4 75 166	Oil mist detector MD-SX. Make: Daihatsu Diesel Mfg. Co., Ltd.
4 75 167	Oil mist detector Vision III C. Make: Specs Corporation
4 75 168	Oil mist detector GDMS-OMDN09. Make: MSS GmbH
4 75 271	Oil mist detector Triton. Make: Heinzmann

Examples of piping diagrams (for make Schaller Automation only) and wiring diagrams (for all other makes) are shown for reference in Figs. 18.06.01a and 18.06.01b.

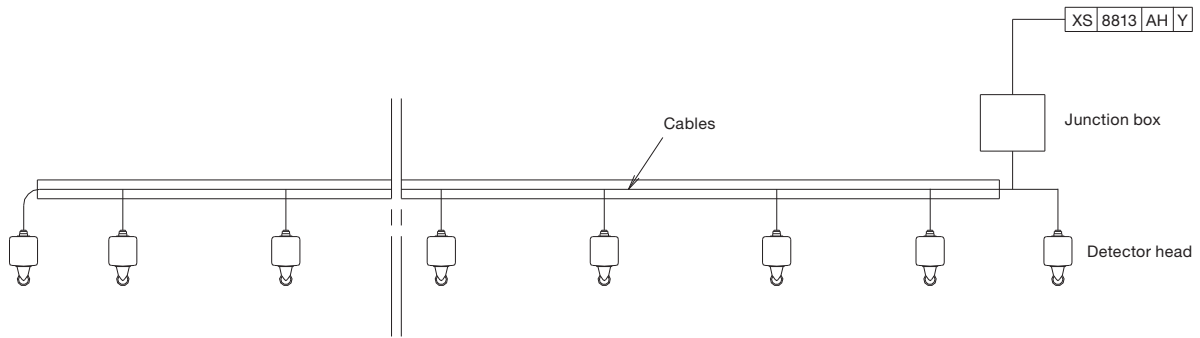

178 49 80-9.3

Fig. 18.06.01a: Oil mist detector wiring on engine, example based on type Graviner MK6 from Kidde Fire Protection, option: 4 75 161

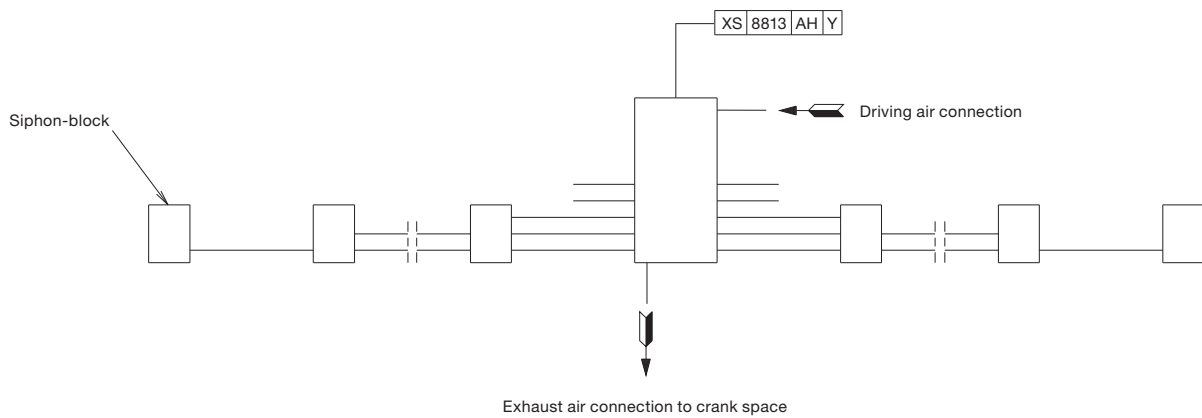

178 49 81-0.3

Fig. 18.06.01b: Oil mist detector pipes on engine, type Visatron VN215/93 from Schaller Automation, option: 4 75 163



**Bearing Wear Monitoring System**

The Bearing Wear Monitoring (BWM) system monitors all three principal crank-train bearings using two proximity sensors forward/aft per cylinder unit and placed inside the frame box.

Targeting the guide shoe bottom ends continuously, the sensors measure the distance to the crosshead in Bottom Dead Center (BDC). Signals are computed and digitally presented to computer hardware, from which a useable and easily interpretable interface is presented to the user.

The measuring precision is more than adequate to obtain an alarm well before steel-to-steel contact in the bearings occur. Also the long-term stability of the measurements has shown to be excellent.

In fact, BWM is expected to provide long-term wear data at better precision and reliability than the manual vertical clearance measurements normally performed by the crew during regular service checks.

For the above reasons, we consider unscheduled open-up inspections of the crank-train bearings to be superfluous, given BWM has been installed.

Two BWM 'high wear' alarm levels including deviation alarm apply. The first level of the high wear / deviation alarm is indicated in the alarm panel only while the second level also activates a slow down.

The Extent of Delivery lists four Bearing Wear Monitoring options of which the two systems from Dr. E. Horn and Kongsberg Maritime could also include Bearing Temperature Monitoring:

4 75 261	Bearing Wear Monitoring System XTS-W. Make: AMOT
4 75 262	Bearing Wear Monitoring System BDMS. Make: Dr. E. Horn
4 75 263	Bearing Wear Monitoring System PS-10. Make: Kongsberg Maritime
4 75 264	Bearing Wear Monitoring System OPEN-predictor. Make: Rovsing Dynamics

ME, ME-C and -GI engines are as standard specified with Bearing Wear Monitoring for which any of the above mentioned options could be chosen.

**Bearing Temperature Monitoring System**

The Bearing Temperature Monitoring (BTM) system continuously monitors the temperature of the bearing. Some systems measure the temperature on the backside of the bearing shell directly, other systems detect it by sampling a small part of the return oil from each bearing in the crankcase.

In case a specified temperature is recorded, either a bearing shell/housing temperature or bearing oil outlet temperature alarm is triggered.

In main bearings, the shell/housing temperature or the oil outlet temperature is monitored depending on how the temperature sensor of the BTM system, option: 4 75 133, is installed.

In crankpin and crosshead bearings, the shell/housing temperature or the oil outlet temperature is monitored depending on which BTM system is installed, options: 4 75 134 or 4 75 135.

For shell/housing temperature in main, crankpin and crosshead bearings two high temperature alarm levels apply. The first level alarm is indicated in the alarm panel while the second level activates a slow down.

For oil outlet temperature in main, crankpin and crosshead bearings two high temperature alarm levels including deviation alarm apply. The first level of the high temperature / deviation alarm is indicated in the alarm panel while the second level activates a slow down.

In the Extent of Delivery, there are three options:

4 75 133	Temperature sensors fitted to main bearings
4 75 134	Temperature sensors fitted to main bearings, crankpin bearings, crosshead bearings and for moment compensator, if any
4 75 135	Temperature sensors fitted to main bearings, crankpin bearings and crosshead bearings



**Water In Oil Monitoring System**

All MAN B&W engines are as standard specified with Water In Oil monitoring system in order to detect and avoid free water in the lubricating oil.

In case the lubricating oil becomes contaminated with an amount of water exceeding our limit of 50% of the saturation point (corresponding to approx. 0.2% water content), acute corrosive wear of the crosshead bearing overlayer may occur. The higher the water content, the faster the wear rate.

To prevent water from accumulating in the lube oil and, thereby, causing damage to the bearings, the oil should be monitored manually or automatically by means of a Water In Oil (WIO) monitoring system connected to the engine alarm and monitoring system. In case of water contamination the source should be found and the equipment inspected and repaired accordingly.

The saturation point of the water content in the lubricating oil varies depending on the age of the lubricating oil, the degree of contamination and the temperature. For this reason, we have chosen to specify the water activity measuring principle and the aw-type sensor. Among the available methods of measuring the water content in the lubricating oil, only the aw-type sensor measures the relationship between the water content and the saturation point regardless of the properties of the lubricating oil.

WIO systems with aw-type sensor measure water activity expressed in 'aw' on a scale from 0 to 1. Here, '0' indicates oil totally free of water and '1' oil fully saturated by water.

Alarm levels are specified as follows:

Engine condition	Water activity, aw
High alarm level	0.5
High High alarm level	0.9

The aw = 0.5 alarm level gives sufficient margin to the saturation point in order to avoid free water in the lubricating oil. If the aw = 0.9 alarm level is reached within a short time after the aw = 0.5 alarm, this may be an indication of a water leak into the lubricating oil system.

Please note: Corrosion of the overlayer is a potential problem only for crosshead bearings, because only crosshead bearings are designed with an overlayer. Main, thrust and crankpin bearings may also suffer irreparable damage from water contamination, but the damage mechanism would be different and not as acute.

**Liner Wall Monitoring System**

The Liner Wall Monitoring (LWM) system monitors the temperature of each cylinder liner. It is to be regarded as a tool providing the engine room crew the possibility to react with appropriate countermeasures in case the cylinder oil film is indicating early signs of breakdown.

In doing so, the LWM system can assist the crew in the recognition phase and help avoid consequential scuffing of the cylinder liner and piston rings.

Signs of oil film breakdown in a cylinder liner will appear by way of increased and fluctuating temperatures. Therefore, recording a preset max allowable absolute temperature for the individual cylinder or a max allowed deviation from a calculated average of all sensors will trigger a cylinder liner temperature alarm.

The LWM system includes two sensors placed in the manoeuvring and exhaust side of the liners, near the piston skirt TDC position. The sensors are interfaced to the ship alarm system which monitors the liner temperatures.

For each individual engine, the max and deviation alarm levels are optimised by monitoring the temperature level of each sensor during normal service operation and setting the levels accordingly.

The temperature data is logged on a PC for one week at least and preferably for the duration of a round trip for reference of temperature development.

All types 98 and 90 ME and ME-C engines as well as K80ME-C9 are as standard specified with Liner Wall Monitoring system. For all other engines, the LWM system is available as an option: 4 75 136.



### LDCL Cooling Water Monitoring System

With the Load Dependent Cylinder Liner (LDCL) cooling water system, the cooling water outlet temperature from the cylinder liner is controlled relative to the engine load, independent of the cooling water outlet from the cylinder cover.

The interval for the liner outlet may be wide, for instance from 70 to 130 degrees Celsius. The cooling water outlet temperature is measured by one sensor for each cylinder liner of the engine.

For monitoring the LDCL cooling water system the following alarm and slow down functionality must be fulfilled:

The Alarm system must be able, from one common analog sensor, to detect two alarm limits and two slow down limits as follows:

- Upper slow down limit
- Upper alarm limit
- Load dependent slow down limit
- Load dependent alarm limit.

An example of the limits is shown in Fig. 18.06.02. The load dependent limits must include at least one break point to allow cut-in/-out of the lower limits. The upper limits are fixed limits without breakpoints.

The values of the load dependent limits are defined as a temperature difference ( $\Delta T$ ) to actual cooling water temperature (which vary relative to the engine load).

The cooling water temperature is plant dependent and consequently, the actual values of both upper limits and load dependent limits are defined during commissioning of the engine.

All 95-50ME-C10/9/-GI dot 2 and higher as well as G50ME-B9.5/3 and S50ME-B9.5 are as standard specified with LDCL Cooling Water Monitoring System while S50ME-B9.3 and G45ME-C9.5/-GI are prepared for the installation of it.

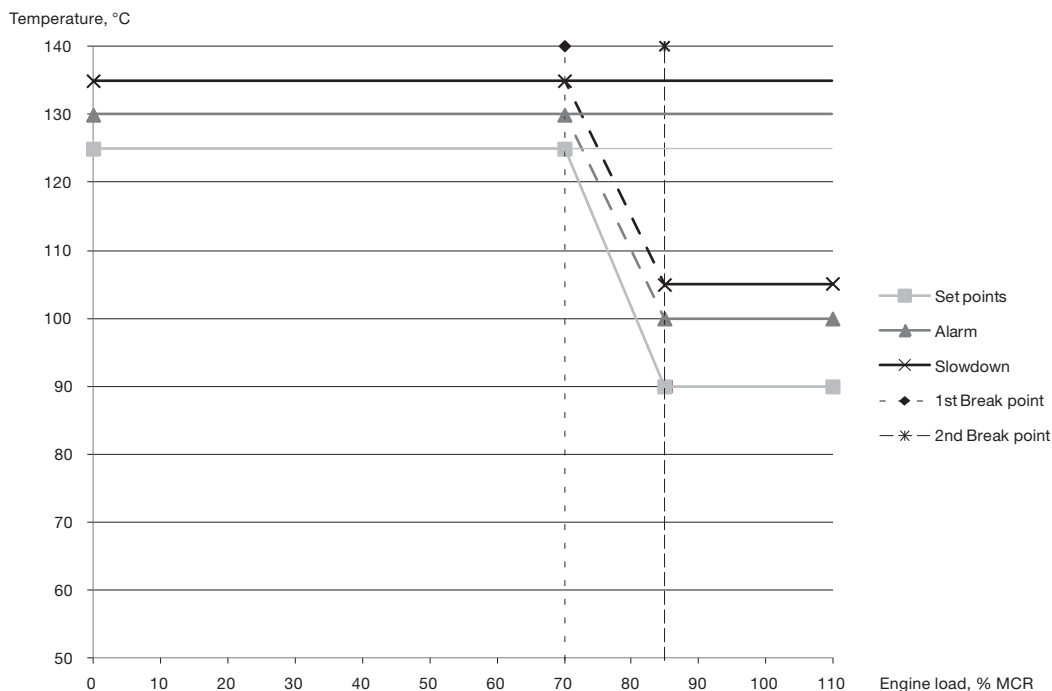

178 68 07-4.0

Fig. 18.06.02: Example of set points versus slow down and alarm limits for LDCL cooling water system



## Control Devices

The control devices mainly include a position switch (ZS) or a position transmitter (ZT) and solenoid valves (ZV) which are listed in Table 18.06.03 below. The sensor identification codes are listed in Table 18.07.01.

Sensor	Point of location
<b>Manoeuvring system</b>	
ZS 1109-A/B C	Turning gear – disengaged
ZS 1110-A/B C	Turning gear – engaged
ZS 1111-A/B C	Main starting valve – blocked
ZS 1112-A/B C	Main starting valve – in service
ZV 1114 C	Slow turning valve
ZS 1116-A/B C	Start air distribution system – in service
ZS 1117-A/B C	Start air distribution system – blocked
ZV 1120 C	Activate pilot press air to starting valves
ZS 1121-A/B C	Activate main starting valves - open
E 1180	Electric motor, auxiliary blower
E 1181	Electric motor, turning gear
E 1185 C	LOP, Local Operator Panel
<b>Hydraulic power supply</b>	
PT 1201-1/2/3 C	Hydraulic oil pressure, after non-return valve
ZV 1202-A/B C	Force-driven pump bypass
PS/PT 1204-1/2/3 C	Lubricating oil pressure after filter, suction side
<b>Tacho/crankshaft position</b>	
ZT 4020	Tacho for safety
<b>Engine cylinder components</b>	
XC 4108 C	ELVA NC valve
ZT 4111 C	Exhaust valve position
ZT 4114 C	Fuel plunger, position 1
<b>Fuel oil</b>	
ZV 8020 Z	Fuel oil cut-off at engine inlet (shut down), Germanischer Lloyd only
<b>Cylinder lubricating oil</b>	
ZT 8203 C	Confirm cylinder lubricator piston movement, cyl/cyl
ZV 8204 C	Activate cylinder lubricator, cyl/cyl
<b>Scavenge air</b>	
PS 8603 C	Scavenge air receiver, auxiliary blower control
<b>ME-GI alarm system (ME-GI only)</b>	
XC 2212	External gas shut down (request)
<b>ME-GI safety system (ME-GI only)</b>	
XC 2001	Engine shut down (command)
XC 6360	Gas plant shut down (command)

Table 18.06.03: Control devices on engine





## Identification of Instruments

The instruments and sensors are identified by a position number which is made up of a combination of letters and an identification number.

### Measured or indicating variables

First letters:

DS	Density switch
DT	Density transmitter
E	Electrical component
FS	Flow switch
FT	Flow transmitter
GT	Gauging transmitter, index/load transmitter
LI	Level indication, local
LS	Level switch
LT	Level transmitter
PDI	Pressure difference indication, local
PDS	Pressure difference switch
PDT	Pressure difference transmitter
PI	Pressure indication, local
PS	Pressure switch
PT	Pressure transmitter
ST	Speed transmitter
TC	Thermo couple (NiCr-Ni)
TE	Temperature element (Pt 100)
TI	Temperature indication, local
TS	Temperature switch
TT	Temperature transmitter
VS	Viscosity switch
VT	Viscosity transmitter
WI	Vibration indication, local
WS	Vibration switch
WT	Vibration transmitter
XC	Unclassified control
XS	Unclassified switch
XT	Unclassified transmitter
ZS	Position switch (limit switch)
ZT	Position transmitter (proximity sensor)
ZV	Position valve (solenoid valve)

### Location of measuring point

Ident. number; first two digits indicate the measurement point and xx the serial number:

11xx	Manoeuvring system
12xx	Hydraulic power supply system (HPS)
13xx	Hydraulic control oil system, separate oil to HPS
14xx	Combustion pressure supervision
15xx	Top bracing pressure, stand alone type
16xx	Exhaust Gas Recirculation (EGR)
20xx	ECS to/from safety system
21xx	ECS to/from remote control system
22xx	ECS to/from alarm system
24xx	ME ECS outputs
29xx	Power supply units to alarm system
30xx	ECS miscellaneous input/output
40xx	Tacho/crankshaft position system
41xx	Engine cylinder components
50xx	VOC, supply system
51xx	VOC, sealing oil system
52xx	VOC, control oil system
53xx	VOC, other related systems
54xx	VOC, engine related components
60xx	GI-ECS to Fuel Gas Supply System (FGSS)
61xx	GI-ECS to Sealing Oil System
62xx	GI-ECS to Control Air System
63xx	GI-ECS to other GI related systems
64xx	GI engine related components
66xx	Selective Catalytic Reduction (SCR) related component. Stand alone
80xx	Fuel oil system
81xx	Lubricating oil system
82xx	Cylinder lubricating oil system
83xx	Stuffing box drain system
84xx	Cooling water systems, e.g. central, sea and jacket cooling water
85xx	Compressed air supply systems, e.g. control and starting air
86xx	Scavenge air system
87xx	Exhaust gas system
88xx	Miscellaneous functions, e.g. axial vibration
90xx	Project specific functions

Table 18.07.01a: Identification of instruments



A0xx Temporary sensors for projects

xxxx-A Alternative redundant sensors

xxxx-1 Cylinder/turbocharger numbers

ECS: Engine Control System

GI: Gas Injection engine

VOC: Volatile Organic Compound

**Functions**

Secondary letters:

- A Alarm
- C Control
- H High
- I Indication, remote
- L Low
- R Recording
- S Switching
- X Unclassified function
- Y Slow down
- Z Shut down

**Repeated signals**

Signals which are repeated, for example measurements for each cylinder or turbocharger, are provided with a suffix number indicating the location, '1' for cylinder 1, etc.

If redundant sensors are applied for the same measuring point, the suffix is a letter: A, B, C, etc.

**Examples**

TI 8005 indicates a local temperature indication (thermometer) in the fuel oil system.

ZS 1112-A,C and ZS 1112-B,C indicate two redundant position switches in the manoeuvring system, A and B, for control of the main starting air valve position.

PT 8501 IALY indicates a pressure transmitter located in the control air supply for remote indication, alarm for low pressure and slow down for low pressure.

078 89 33-9.6.0

Table 18.07.01b: Identification of instruments



**MAN B&W**

---

# Dispatch Pattern, Testing, Spares and Tools

# 19

---

**MAN Diesel**



## Dispatch Pattern, Testing, Spares and Tools

### Painting of Main Engine

The painting specification, Section 19.02, indicates the minimum requirements regarding the quality and the dry film thickness of the coats of, as well as the standard colours applied on MAN B&W engines built in accordance with the 'Copenhagen' standard.

Paints according to builder's standard may be used provided they at least fulfil the requirements stated.

### Dispatch Pattern

The dispatch patterns are divided into two classes, see Section 19.03:

- A: Short distance transportation and short term storage
- B: Overseas or long distance transportation or long term storage.

**Short distance transportation (A)** is limited by a duration of a few days from delivery ex works until installation, or a distance of approximately 1,000 km and short term storage.

The duration from engine delivery until installation must not exceed 8 weeks.

Dismantling of the engine is limited as much as possible.

**Overseas or long distance transportation** or long term storage require a class B dispatch pattern.

The duration from engine delivery until installation is assumed to be between 8 weeks and maximum 6 months.

Dismantling is effected to a certain degree with the aim of reducing the transportation volume of the individual units to a suitable extent.

*Note:*

*Long term preservation and seaworthy packing are always to be used for class B.*

Furthermore, the dispatch patterns are divided into several degrees of dismantling in which '1' comprises the complete or almost complete engine. Other degrees of dismantling can be agreed upon in each case.

When determining the degree of dismantling, consideration should be given to the lifting capacities and number of crane hooks available at the engine maker and, in particular, at the yard (purchaser).

The approximate masses of the sections appear in Section 19.04. The masses can vary up to 10% depending on the design and options chosen.

Lifting tools and lifting instructions are required for all levels of dispatch pattern. The lifting tools, options: 4 12 110 or 4 12 111, are to be specified when ordering and it should be agreed whether the tools are to be returned to the engine maker, option: 4 12 120, or not, option: 4 12 121.

MAN Diesel & Turbo's recommendations for preservation of disassembled / assembled engines are available on request.

Furthermore, it must be considered whether a drying machine, option: 4 12 601, is to be installed during the transportation and/or storage period.

### Shop Trials/Delivery Test

Before leaving the engine maker's works, the engine is to be carefully tested on diesel oil in the presence of representatives of the yard, the ship-owner and the classification society.

The shop trial test is to be carried out in accordance with the requirements of the relevant classification society, however a minimum as stated in Section 19.05.



MAN Diesel & Turbo's recommendations for shop trial, quay trial and sea trial are available on request.

In connection with the shop trial test, it is required to perform a pre-certification survey on engine plants with FPP or CPP, options: 4 06 201 Engine test cycle E3 or 4 06 202 Engine test cycle E2 respectively.

## **Spare Parts**

### **List of spare parts, unrestricted service**

The tendency today is for the classification societies to change their rules such that required spare parts are changed into recommended spare parts.

MAN Diesel & Turbo, however, has decided to keep a set of spare parts included in the basic extent of delivery, EoD: 4 87 601, covering the requirements and recommendations of the major classification societies, see Section 19.06.

This amount is to be considered as minimum safety stock for emergency situations.

### **Additional spare parts recommended by MAN Diesel & Turbo**

The above-mentioned set of spare parts can be extended with the 'Additional Spare Parts Recommended by MAN Diesel & Turbo', option: 4 87 603, which facilitates maintenance because, in that case, all the components such as gaskets, sealings, etc. required for an overhaul will be readily available, see Section 19.07.

## **Wearing parts**

The consumable spare parts for a certain period are not included in the above mentioned sets, but can be ordered for the first 1, 2, up to 10 years' service of a new engine, option: 4 87 629.

The wearing parts that, based on our service experience, are estimated to be required, are listed with service hours in Tables 19.08.01 and 19.08.02.

## **Large spare parts, dimensions and masses**

The approximate dimensions and masses of the larger spare parts are indicated in Section 19.09. A complete list will be delivered by the engine maker.

## **Tools**

### **List of standard tools**

The engine is delivered with the necessary special tools for overhauling purposes. The extent, dimensions and masses of the main tools is stated in Section 19.10. A complete list will be delivered by the engine maker.

### **Tool panels**

Most of the tools are arranged on steel plate panels, EoD: 4 88 660, see Section 19.11 'Tool Panels'.

It is recommended to place the panels close to the location where the overhaul is to be carried out.



**Specification for painting of main engine**

Components to be painted before shipment from workshop	Type of paint	No. of coats / Total Nominal Dry Film Thickness (NDFT) $\mu\text{m}$	Colour: RAL 840HR DIN 6164 MUNSELL
<b>1. Component/surfaces exposed to oil and air, inside engine</b>			
Unmachined surfaces all over. However, cast type crankthrows, main bearing cap, crosshead bearing cap, crankpin bearing cap, pipes inside crankcase and chainwheel need not to be painted, but the cast surface must be cleaned of sand and scales and be kept free of rust.	In accordance with corrosivity categories C2 Medium ISO 12944-5		Free  White: RAL 9010 DIN N:0:0.5 MUNSELL N-9.5
	Engine alkyd primer, weather resistant. Oil and acid resistant alkyd paint. Temperature resistant to minimum 80 °C.	1 - 2 layer(s) Total NDTF 80 $\mu\text{m}$  1 layer Total NDTF 40 $\mu\text{m}$  - - - - - Total NDTF 120 $\mu\text{m}$	
<b>2. Components, outside engine</b>			
Engine body, pipes, gallery, brackets, etc.  Delivery standard is in a primed and finished-painted condition, unless otherwise stated in the contract.	In accordance with corrosivity categories C2 Medium ISO 12944-5		Free  Light green: RAL 6019 DIN 23:2:2 MUNSELL 10GY 8/4
	Engine alkyd primer, weather resistant. Final alkyd paint resistant to salt water and oil, option: 4 81 103.	1 - 2 layer(s) Total NDTF 80 $\mu\text{m}$  1 layer Total NDTF 40 $\mu\text{m}$  - - - - - Total NDTF 120 $\mu\text{m}$	
<b>3. Gas pipe (ME-GI/ME-LGI only)</b>			
Chain pipes, supply pipe.	In accordance with corrosivity categories C2 Medium ISO 12944-5		Free  Yellow: RAL 1021  MUNSELL 2.5 Y 8114  Violet: RAL 4001 MUNSELL 2.5P 4/11
	Engine alkyd primer, weather resistant. Final alkyd paint resistant to salt water and oil, option: 4 81 103.  ME-LGI only: additional marking tape on pipes acc. to ISO 14726:2008.	1 - 2 layer(s) Total NDTF 80 $\mu\text{m}$  1 layer Total NDTF 40 $\mu\text{m}$  - - - - - Total NDTF 120 $\mu\text{m}$	
<b>4. Heat affected components</b>			
Supports for exhaust receiver. Scavenge air cooler housing inside and outside. No surface in the cooler housing may be left unpainted.  Exhaust valve housing (exhaust flange), (Non water cooled housing only).	In accordance with corrosivity categories C3 Medium ISO 12944-5		
	Ethyl silicate based zinc-rich paint, heat resistant to minimum 300 °C.	1 layer  - - - - - Total NDTF 80 $\mu\text{m}$	



Components to be painted before shipment from workshop	Type of paint	No. of coats / Total Nominal Dry Film Thickness (NDFT) $\mu\text{m}$	Colour: RAL 840HR DIN 6164 MUNSELL
<b>5. Components affected by water, cleaning agents, and acid fluid below neutral Ph</b>			
Scavenge air cooler box inside. (Reversing chamber).  Preparation, actual number of coats, film thickness per coat, etc. must be according to the paint manufacturer's specifications.  Air flow reversing chamber inside and outside.  No surface may be left unpainted. Supervision from manufacturer is recommended in the phase of introduction of the paint system.	In accordance with corrosivity categories C5-M High ISO 12944-5  Two-component epoxy phenolic.	3 layers  — — — — — Total NDFT 350 $\mu\text{m}$  See specifications from product data sheet.	Free
<b>6. Gallery plates, top side</b>	Engine alkyd primer, weather resistant.	C2 Medium 1-2 layer(s)  — — — — — Total NDFT 80 $\mu\text{m}$	
<b>7. EGR system</b> Normal air cooler housing with EGR mix point to scavenge air receiver non-return valves (500 $\mu\text{m}$ ).  Normal air cooler housing inside – from outlet air cooler – through reversing chamber and water mist catcher to non-return valves housing in scavenge air receiver.	Vinyl ESTER acrylic copolymer.  Note: Duplex/Stainless steel is not to be painted.	Total NDFT 500 - 1,200 $\mu\text{m}$	Free
<b>8. Purchased equipment and instruments painted in maker's colour are acceptable, unless otherwise stated in the contract</b>			
Tools are to be surface treated according to specifications stated in the drawings.  Purchased equipment painted in maker's colour is acceptable, unless otherwise stated in the contract/drawing.	Electro(-) galvanised.	See specifications from product data sheet.	
Tool panels	Oil resistant paint.	1 - 2 layer(s)  — — — — — Total NDFT 80 $\mu\text{m}$	Light grey: RAL 7038 DIN 24:1:2 MUNSELL N-7.5

All paints must be of good quality. Paints according to builder's standard may be used provided they at least fulfil the above requirements.

The data stated are only to be considered as guidelines. Preparation, number of coats, film thickness per coat, etc., must be in accordance with the paint manufacturer's specifications.

074 33 57-9.11.1

Fig. 19.02.01: Painting of main engine, option: 4 81 101, 4 81 102 or 4 81 103



## Dispatch Pattern

The relevant engine supplier is responsible for the actual execution and delivery extent. As differences may appear in the individual suppliers' extent and dispatch variants.

### **Dispatch Pattern A - short:**

Short distance transportation limited by duration of transportation time within a few days or a distance of approximately 1000 km and short term storage.

Duration from engine delivery to installation must not exceed eight weeks.  
Dismantling must be limited.

### **Dispatch Pattern B - long:**

Overseas and other long distance transportation, as well as long-term storage.

Dismantling is effected to reduce the transport volume to a suitable extent.

Long-term preservation and seaworthy packing must always be used.

### *Note*

*The engine supplier is responsible for the necessary lifting tools and lifting instructions for transportation purposes to the yard. The delivery extent of lifting tools, ownership and lend/lease conditions are to be stated in the contract. (Options: 4 12 120 or 4 12 121)*

*Furthermore, it must be stated whether a drying machine is to be installed during the transportation and/or storage period. (Option: 4 12 601)*





Dispatch pattern variants

**A1 + B1** (option 4 12 021 + 4 12 031)  
Engine complete, i.e. not disassembled

**A1 + B1**

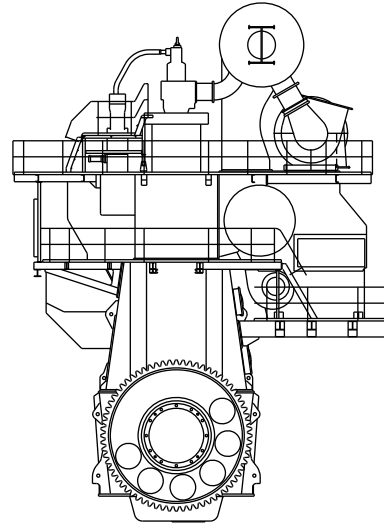

Engine complete

- A2 + B2** (option 4 12 022 + 4 12 032)
- Top section including cylinder frame complete, cylinder covers complete, scavenge air receiver including cooler box and cooler insert, turbocharger(s), piston complete and galleries with pipes, HCU units and oil filter
  - Bottom section including bedplate complete, frame box complete, connecting rods, turning gear, crankshaft complete and galleries
  - Remaining parts including stay bolts, chains, FIVA valves etc.

**A2 + B2**

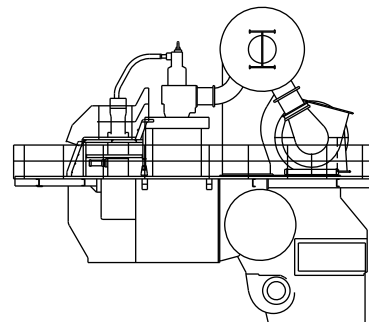

Top section

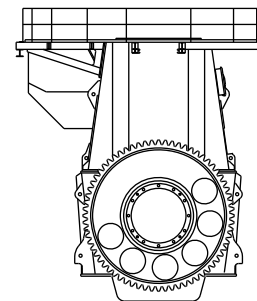

Bottom section

Fig. 19.03.01: Dispatch pattern, engine with turbocharger on exhaust side (4 59 123)

074 27 27-7.0.0a

**A3 + B3** (option 4 12 023 + 4 12 033)

- Top section including cylinder frame complete, cylinder covers complete, scavenge air receiver including cooler box and cooler insert, turbocharger(s), piston complete and galleries with pipes, HCU Units
- Frame box section including frame box complete, chain drive, connecting rods and galleries, gearbox for hydraulic power supply, hydraulic pump station and oil filter
- Bedplate/crankshaft section including bedplate complete, crankshaft complete with chain-wheels and turning gear
- Remaining parts including stay bolts, chains FIVA valves, etc.

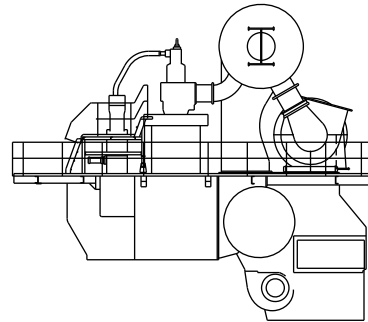
**A3 + B3**

Top section

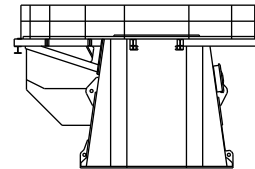

Frame box section

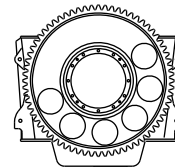

Bedplate/crankshaft section

074 27 27-7.0.0b

*Fig. 19.03.02: Dispatch pattern, engine with turbocharger on exhaust side (4 59 123)*



**A4 + B4** (option 4 12 024 + 4 12 034)

- Top section including cylinder frame complete, cylinder covers complete, piston complete and galleries with pipes on manoeuvring side, HCU units
- Exhaust receiver with pipes
- Scavenge air receiver with galleries and pipes
- Turbocharger
- Air cooler box with cooler insert
- Frame box section including frame box complete, chain drive, connecting rods and galleries, gearbox for hydraulic power supply, hydraulic power station and oil filter
- Crankshaft with chain wheels
- Bedplate with pipes and turning gear
- Remaining parts including stay bolts, auxiliary blowers, chains FIVA valves etc.

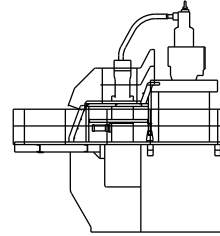

Top section

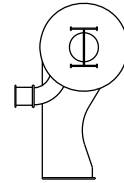

Exhaust receiver

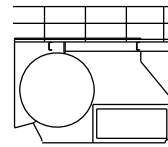

Scavenge air receiver



Turbocharger

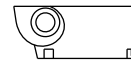

Air cooler box

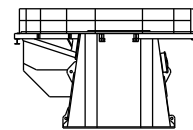

Frame box section

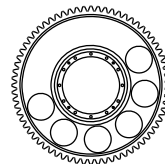

Crankshaft section

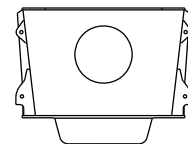

Bedplate section

074 27 27-7.0.1c

Fig. 19.03.03: Dispatch pattern, engine with turbocharger on exhaust side (4 59 123)



## Shop Test

### Minimum delivery test

The minimum delivery test, EoD: 4 14 001, involves:

- Starting and manoeuvring test at no load
- Load test  
Engine to be started and run up to 50% of Specified MCR (M) in 1 hour

### Followed by:

- 0.50 hour running at 25% of specified MCR
- 0.50 hour running at 50% of specified MCR
- 0.50 hour running at 75% of specified MCR
- 1.00 hour running at 100% of specified MCR
- 0.50 hour running at 110% of specified MCR

### Only for Germanischer Lloyd:

- 0.75 hour running at 110% of specified MCR

### Governor tests, etc:

- Governor test
- Minimum speed test
- Overspeed test
- Shut down test
- Starting and reversing test
- Turning gear blocking device test
- Start, stop and reversing from the Local Operating Panel (LOP)

### Fuel oil test

Before leaving the factory, the engine is to be carefully tested on diesel oil in the presence of representatives of Yard, Shipowner, Classification Society, and MAN Diesel & Turbo.

At each load change, all temperature and pressure levels etc. should stabilise before taking new engine load readings.

Fuel oil analysis is to be presented.

All tests are to be carried out on diesel or gas oil.

### EIAPP certificate

Most marine engines installed on ocean going vessels are required to have an 'Engine International Air Pollution Prevention' (EIAPP) Certificate, or similar. Therefore, a pre-certification survey is to be carried out for all engines according to the survey method described in the engine's NO<sub>x</sub> Technical File, which is prepared by the engine manufacturer. For MAN B&W engines, the Unified Technical File (UTF) format is recommended.

The EIAPP certificate documents that the specific engine meets the international NO<sub>x</sub> emission limitations specified in Regulation 13 of MARPOL Annex VI. The basic engine 'Economy running mode', EoD: 4 06 200, complies with these limitations.

The pre-certification survey for a 'Parent' or an 'Individual' engine includes NO<sub>x</sub> measurements during the delivery test. For 'Member' engines, a survey according to the group definition for the engine group is needed. This survey should be based on the delivery test.

The applicable test cycles are:

- E3, marine engine, propeller law for FPP, option: 4 06 201
- or
- E2, marine engine, constant speed for CPP, option: 4 06 202

For further information and options regarding shop test, see Extent of Delivery.



## List of Spare Parts, Unrestricted Service

Spare parts are **requested** by the following Classes only: GL, KR, NK and RS, while just **recommended** by: ABS and LR, but neither requested nor recommended by: BV, CCS, DNV and RINA.

### Cylinder cover, plate 901 and others

- 1 Cylinder cover with fuel, exhaust and starting valves, indicator valve and sealing rings (disassembled)
- ½ set Studs for 1 cylinder cover

### Piston, plate 902

- 1 Piston complete (with cooling pipe), piston rod, piston rings and stuffing box, studs and nuts
- 1 set Piston rings for 1 cylinder

### Cylinder liner, plate 903

- 1 Cylinder liner inclusive of sealing rings and gaskets.

### Cylinder lubricating oil system, plate 903 <sup>1)</sup>

- 1 set Spares for lubricating oil system for 1 cyl.
- 2 Lubricator backup cable

### Connecting rod, and crosshead bearing, plate 904

- 1 Telescopic pipe with bushing for 1 cylinder
- 1 Crankpin bearing shells in 2/2 with studs and nuts
- 1 Crosshead bearing shell lower part with studs and nuts
- 2 Thrust pieces

### Thrust block, plate 905

- 1 set Thrust pads for 'ahead'  
For NK also one set 'astern' if different from 'ahead'

### HPS - Hydraulic Power Supply, plate 906 <sup>1 and 2)</sup>

- 1 Proportional valve for hydraulic pumps
- 1 Leak indicator
- 1 Safety coupling for hydraulic pump
- 1 Accumulator
- 6 Chain links. Only for ABS, LR and NK
- 1 set Flex pipes, one of each size

### Engine control system, plate 906 <sup>2)</sup>

- 1 Multi Purpose Controller MPC
- 1 Multi Purpose Controller MPC-10, if applied
- 1 Amplifier for Auxiliary Control Unit. Only for 200 bar HPS
- 1 Position Amplifier. Only for 200 bar HPS
- 1 Trigger sensor for tacho system, only if trigger ring
- 1 Marker sensor for tacho system

- 1 Tacho signal amplifier
- 1 ID-key
- 1 Encoder
- 1 Fuse kit

### Starting valve, plate 907

- 1 Starting valve, complete
- 1 Solenoid valve <sup>1)</sup>

### Hydraulic cylinder unit, plate 907 <sup>1 and 2)</sup>

- 1 Fuel booster barrel, complete with plunger
- 1 FIVA valve complete
- 1 Suction valve complete
- 1 set Flex pipes, one of each size
- 1 High-pressure pipe kit
- 1 Packing kit

### Exhaust valve, plate 908

- 2 Exhaust valves complete  
(The 2nd exhaust valve is mounted in the Cylinder cover complete)
- 1 High-pressure pipe from actuator to exhaust valve
- 1 Exhaust valve position sensor

### Fuel valve, plate 909

- 1 set Fuel valves of each size and type fitted, complete with all fittings, for one engine
  - a) engines with one or two fuel valves: one set of fuel valves for all cylinders on the engine
  - b) engines with three and more fuel valves per cylinder: two fuel valves complete per cylinder, and a sufficient number of valve parts, excluding the body, to form, with those fitted in the complete valve, a full engine set
- 1 set High-pressure pipe, from fuel oil pressure booster to fuel valve

### Turbocharger, plate 910

- 1 set Maker's standard spare parts

### Bedplate, plate 912

- 1 Main bearing shell (1 upper and 1 lower) of each size
- 1 set Studs and nuts for 1 main bearing

<sup>1)</sup> MD required spare parts.

<sup>2)</sup> All spare parts are requested by all Classes.

*Please note: Plate number refers to Instruction Book, Vol. III containing plates with spare parts*

Fig. 19.06.01: List of spare parts, unrestricted service: 4 87 601



## Additional Spares

Beyond class requirements or recommendation, for easier maintenance and increased security in operation.

### Cylinder cover, section 90101

- 4 Studs for exhaust valve
- 4 Nuts for exhaust valve
- 1/2 set O-rings for cooling jacket
- 1 Cooling jacket
- 1/2 set Sealing between cylinder cover and liner
- 4 Spring housings for fuel valve

### Hydraulic tool for cylinder cover, section 901

- 1 set Hydraulic hoses with protection hose complete with couplings
- 8 pcs O-rings with backup rings, upper
- 8 pcs O-rings with backup rings, lower

### Piston and piston rod, section 90201

- 1 box Locking wire, L=63 m
- 5 Piston rings of each kind
- 2 D-rings for piston skirt
- 2 D-rings for piston rod

### Piston rod stuffing box, section 90202

- 15 Self-locking nuts
- 5 O-rings
- 5 Top scraper rings
- 15 Pack sealing rings
- 10 Cover sealing rings
- 120 Lamellas for scraper rings
- 30 Springs for top scraper and sealing rings
- 20 Springs for scraper rings

### Cylinder frame, section 90301

- 1/2 set Studs for cylinder cover for one cylinder
- 1 Bushing

### Cylinder liner and cooling jacket, section 90301

- 1 Cooling jacket of each kind
- 4 Non return valves
- 1 set O-rings for one cylinder liner
- 1/2 set Gaskets for cooling water connection
- 1/2 set O-rings for cooling water pipes
- 1 set Cooling water pipes between liner and cover for one cylinder

### Cylinder Lubricating Oil System, section 90302

- 1 set Spares for MAN B&W Alpha lubricating oil system for one cylinder
- 1 Lubricator
- 2 Feed back sensor, complete
- 1 Complete sets of O-rings for lubricator (depending on number of lubricating nozzles per cylinder)

### Connecting rod and crosshead, section 90401

- 1 Telescopic pipe
- 2 Thrust piece

### HPS Hydraulic Power Supply, section 906

- 1 Delivery pump
- 1 Start up pump
- 1 Pressure relief valve
- 1 Pumps short cutting valve
- 1 set Check valve Cartridge (3 pcs)

### Engine Control System, section 906

- 1 set Fuses for MPC, TSA, CNR
- 1 Segment for trigger ring

### HCU Hydraulic Cylinder Unit, section 906

- 1 set Packings

### Main starting valve, section 90702

- 1 Repair kit for main actuator
- 1 Repair kit for main ball valve
- 1 \*) Repair kit for actuator, slow turning
- 1 \*) Repair kit for ball valve, slow turning

\*) if fitted

### Starting valve, section 907

- 2 Locking plates
- 2 Piston
- 2 Spring
- 2 Bushing
- 1 set O-ring
- 1 Valve spindle

Fig. 19.07.01a: Additional spare parts beyond class requirements or recommendation, option: 4 87 603

**Exhaust valve, section 908**

- 1 Exhaust valve spindle
- 1 Exhaust valve seat
- 1/2 set O-ring exhaust valve/cylinder cover
- 4 Piston rings
- 1/2 set Guide rings
- 1/2 set Sealing rings
- 1/2 set Safety valves
- 1 set Gaskets and O-rings for safety valve
- 1 Piston complete
- 1 Damper piston
- 1 set O-rings and sealings between air piston and exhaust valve housing/spindle
- 1 Liner for spindle guide
- 1 set Gaskets and O-rings for cooling water connection
- 1 Conical ring in 2/2
- 1 set O-rings for spindle/air piston
- 1 set Non-return valve

**Exhaust valve, section 908**

- 1 Sealing oil control unit

**Exhaust valve actuator, section 908**

- 1 Hydraulic exhaust valve actuator complete for one cylinder
- 1 Electronic exhaust valve control valve

**Cooling water outlet, section 908**

- 2 Ball valve
- 1 Butterfly valve
- 1 Compensator
- 1 set Gaskets for butterfly valve and compensator

**Fuel valve, section 909**

- 1 set Fuel nozzles
- 1 set O-rings for fuel valve
- 3 Spindle guides, complete
- 1/2 set Springs
- 1/2 set Discs, +30 bar
- 3 Thrust spindles
- 3 Non return valve (if mounted)

**Fuel oil high pressure pipes, section 90914**

- 1 High pressure pipe, from fuel oil pressure booster to fuel valve
- 1 High pressure pipe from actuator to exhaust valve
- 1 set O-rings for high pressure pipes

**Overflow valve, section 909**

- 1 Overflow valve, complete
- 1 O-rings of each kind

**Fuel injection system, section 909**

- 1 Fuel oil pressure booster complete, for one cyl.
- 1 Hydraulic cylinder unit
- 1 set Gaskets and sealings
- 1 Electronic fuel injection control valve
- 1 Hydraulic cylinder unit

**Scavenge air receiver, section 91002**

- 2 Non-return valves complete
- 1 Compensator

**Exhaust pipes and receiver, section 910**

- 1 Compensator between TC and receiver
- 2 Compensator between exhaust valve and receiver
- 1 set Gaskets for each compensator

**Auxiliary blower, section 91003**

- 1 set Bearings for electric motor
- 1 set Shaft sealings
- 1 set Bearings/belt/sealings for gearbox (only for belt-driven blowers)

**Turbocharger, section 91005**

- 1 Spare rotor for one turbocharger, complete with bearing
- 1 set Spare parts for one turbocharger

**Arrangement of safety cap, section 911**

- 1 set Bursting disc

**Engine Lubricating System, section 912**

- 1 set 6 $\mu$  filter

Note: Section numbers refer to Instruction Book, Vol. III containing plates with spare parts

Fig. 19.07.01b: Additional spare parts beyond class requirements or recommendation, option: 4 87 603



## Wearing Parts

MAN Diesel & Turbo Service Letter SL-509 provides Guiding Overhaul Intervals and expected service life for key engine components.

The wearing parts expected to be replaced at the service hours mentioned in the Service Letter are listed in the tables below.

Service hours	8,000	12,000	16,000	20,000	24,000	32,000	36,000	40,000	48,000	56,000	60,000	64,000	72,000	80,000	84,000	88,000	96,000
	Replace parts																
<b>Description</b>																	
Piston																	
▪ Soft iron gasket (1 set per cylinder)					x				x				x				x
▪ Piston crown (1 pc per cylinder)													x				
▪ O-rings for piston (1 set per cylinder)													x				
▪ Piston rings (1 set per cylinder)					x				x				x				x
▪ Piston cleaning ring (1 pc per cylinder)													x				
Stuffing box																	
▪ Lamellas (1 set per cylinder)					x				x				x				x
▪ Top scraper ring (1 pc per cylinder)					x				x				x				x
▪ O-rings (1 set per cylinder)					x				x				x				x
Cylinder liner (1 pc per cylinder)													x				
▪ O-rings for cylinder liner (1 set per cylinder)													x				
▪ O-rings for cooling water jacket (1 set per cylinder)													x				
▪ O-rings for cooling water connections (1 set per cyl.)													x				
Exhaust valve																	
▪ DuraSpindle (1 pc per cylinder)																	x
▪ Nimonic spindle (1 pc per cylinder)																	x
▪ Bottom piece (1 pc per cylinder)																	x
▪ Piston rings for exhaust valve & oil piston (1 set per cyl.)																	x
▪ O-rings for bottom piece (1 set per cylinder)	x					x						x					x
Fuel valves																	
▪ Valve nozzle (2 sets per cylinder)			x			x			x			x		x			x
▪ Spindle guide (2 sets per cylinder)			x			x			x			x		x			x
▪ O-ring (2 sets per cylinder)	x		x		x	x		x	x	x		x	x	x		x	x
▪ Spring housings (1 set per cylinder)																	x
Bearings																	
▪ Crosshead bearing (1 set per cylinder)												x					
▪ Crankpin bearing (1 set per cylinder)																	x
▪ Main bearing (1 set per cylinder)																	x
▪ Thrust bearing (1 set per engine)																	x
Cylinder cover (1 pc per cylinder)																	x
▪ O-rings for cooling water jacket (1 set per cylinder)					x				x				x				x
▪ O-ring for starting valve (1 pc per cylinder)		x			x		x		x		x		x		x		x

Table 19.08.01a: Wearing parts according to Service Letter SL-509





Description	Service hours	8,000	12,000	16,000	20,000	24,000	32,000	36,000	40,000	48,000	56,000	60,000	64,000	72,000	80,000	84,000	88,000	96,000	
		Replace parts																	
Air cooler(s) (1 pc per turbocharger)										x									x
Chains (1 set per engine)																			x
Turbocharger(s) *)																			
Alpha Lubricator																			
▪ Solenoid valve (1 pc per pump)						x				x				x					x
▪ Non-return valve (1 pc per pump piston)						x				x				x					x
▪ O-rings (1 set per lubricator)						x				x				x					x
Mechanical cylinder lubricator *)																			
ME Parts																			
▪ Hydraulic hoses (1 set per engine)							x						x						x
▪ FIVA valve (1 pc per cylinder)													x						
▪ Fuel oil pressure booster (1 pc per cylinder)													x						
▪ Angle encoder (2 pcs per engine)													x						
▪ MPC (1 pc per cylinder + 7 pcs)													x						
▪ MOP A (1 pc per engine)													x						
▪ MOP B (1 pc per engine)													x						
▪ CCU amplifier (1 pc per cylinder)													x						
▪ ACU amplifier (3 pcs per engine)													x						
▪ LVDT hydraulic pump amplifier (3 pcs per engine)													x						
▪ LDI hydraulic pump amplifier (3 pcs per engine)													x						
▪ Proportional valve for main hydraulic pump					x				x			x			x				
▪ Hydrostatic bearings for main hydraulic pump							x						x						x
▪ Sealings for pressure relief valve for main hydr. pump									x						x				
▪ Static sealing rings for exh. valve actuator (1 pc per cyl.)							x						x						x
▪ Membranes for accumulators on HPS							x						x						x
▪ Membranes for accumulators on HCU							x						x						x
▪ Fuel booster sensor (1 pc per cylinder)													x						
▪ Exhaust valve sensor (1 pc per cylinder)													x						
▪ Marker sensor (1 pc per engine)													x						
▪ Cables (1 set per engine)																			x
▪ Gear wheel bearings (1 set per engine)																			x
ME-GI Parts																			
▪ Gas nozzles (1 set per cylinder) **)			x			x			x			x		x		x			x
▪ Sealings rings and gaskets for gas nozzles (1 set per engine)**)	x	x		x	x	x	x	x	x	x	x	x	x	x	x	x	x	x	x

\*) According to manufacturer's recommendations.

\*\*\*) For -GI engines only

Table 19.08.01b: Wearing parts according to Service Letter SL-509



## List of Standard Tools for Maintenance

The engine is delivered with all necessary special tools for scheduled maintenance. The extent of the tools is stated below. Most of the tools are arranged on steel plate panels. It is recommended to place them close to the location where the overhaul is to be carried out, see Section 19.11.

All measurements are for guidance only.

### Cylinder Cover, MF/SF 21-9010

- 1 pcs Tool panel incl. lifting chains, grinding mandrels, extractor tools etc.
- 1 pcs Cylinder cover rack
- 1 set Lifting tools for cylinder cover

### Cylinder Unit Tools, MF/SF 21-9014

- 1 pcs Tool panel incl. pressure testing tool, piston ring expander, stuffing box tools, templates etc.
- 1 pcs Guide ring for piston
- 1 pcs Lifting tool for piston
- 1 pcs Support iron for piston
- 1 pcs Crossbar for cylinder liner, piston
- 1 set Measuring tool for cylinder liner
- 1 set Test equipment for accumulator
- 1 pcs ECU temporary backup cable for indicator

### Crosshead and Connection Rod Tools, MF/SF 21-9022

- 1 pcs Tool panel incl. suspension and lifting tools, protection in crankcase etc.
- 1 pcs Crankpin shell, lifting tool

### Crankshaft and Thrust Bearing Tools, MF/SF 21-9026

- 1 pcs Tool panel incl. lifting, testing and retaining tools etc.
- 1 pcs Lifting tool for crankshaft
- 1 pcs Lifting tool for thrust shaft
- 1 pcs Main bearing shell, lifting tool
- 1 set Feeler gauges

### Control Gear Tools, MF/SF 21-9030

- 1 pcs Tool panel incl. pin gauges, chain assembly tools, camshaft tools etc.
- 1 set Hook wrenches for accumulator

### Exhaust Valve Tools, MF/SF 21-9038

- 1 pcs Tool panel incl. grinding-, lifting-, adjustment- and test tools etc.

### Fuel Oil System Tools, MF/SF 21-9042

- 1 pcs Tool panel incl. grinding, lifting, adjustment and assembly tools etc.
- 1 set Fuel valve nozzle tools
- 1 set Toolbox for fitting of fuel pump seals
- 1 pcs Probe light
- 1 pcs Test rig for fuel valve

### Turbocharger System Tools, MF/SF 21-9046

- 1 set Air cooler cleaning tool
- 1 set Guide rails, air cooler element
- 1 pcs Compensator, dismantling tool
- 1 pcs Travelling trolley
- 1 set Blanking plate

### General Tools, MF/SF 21-9058

- 1 set Pump for hydraulic jacks incl. hydraulic accessories
- 1 set Set of tackles, trolleys, eye bolts, shackles, wire ropes
- 1 set Instruments incl. mechanical / digital measuring tools
- 1 set Working platforms incl. supports
- 1 set Hand tools incl. wrenches, pliers and spanners

### Hydraulic Jacks, MF/SF 21-94

It is important to notice, that some jacks are used on different components on the engine

### Personal Safety Equipment, MF/SF 21-9070

- 1 pcs Fall arrest block and rescue harness
- 1 pcs Fall arrest equipment - Optional

### Optional Tools

- 1 pcs Collar ring for piston
- 1 pcs Cylinder wear measuring tool, insertable
- 1 pcs Safety ring for cylinder cover
- 1 pcs Support for tilting tool



- 1 pcs Valve seat and spindle grinder
- 1 pcs Wave cutting machine for cylinder liner
- 1 pcs Wear ridge milling machine
- 1 pcs Work table for exhaust valve
- 1 pcs Crankshaft deflection measuring tool  
(Digital)

**Mass of the complete set of tools: Available on request**



**MAN B&W**

---

---

# Project Support and Documentation

# 20

---

---

**MAN Diesel**



## Project Support and Documentation

The selection of the ideal propulsion plant for a specific newbuilding is a comprehensive task. However, as this selection is a key factor for the profitability of the ship, it is of the utmost importance for the end-user that the right choice is made.

MAN Diesel & Turbo is able to provide a wide variety of support for the shipping and shipbuilding industries all over the world.

The knowledge accumulated over many decades by MAN Diesel & Turbo covering such fields as the selection of the best propulsion machinery, optimisation of the engine installation, choice and suitability of a Power Take Off for a specific project, vibration aspects, environmental control etc., is available to shipowners, shipbuilders and ship designers alike.

Part of this information can be found in the following documentation:

- Marine Engine Programme
- Turbocharger Selection
- Installation Drawings
- CEAS - Engine Room Dimensioning
- Project Guides
- Extent of Delivery (EOD)
- Technical Papers

The publications are available at:  
[www.marine.man.eu](http://www.marine.man.eu) → 'Two-Stroke'.

### Engine Selection Guides

The 'Engine Selection Guides' are intended as a tool to provide assistance at the very initial stage of the project work. The guides give a general view of the MAN B&W two-stroke Programme for MC as well as for ME and ME-B engines and include information on the following subjects:

- Engine data
- Engine layout and load diagrams  
specific fuel oil consumption
- Turbocharger selection
- Electricity production, including power take off
- Installation aspects

- Auxiliary systems
- Vibration aspects.

After selecting the engine type on the basis of this general information, and after making sure that the engine fits into the ship's design, then a more detailed project can be carried out based on the 'Project Guide' for the specific engine type selected.

### Project Guides

For each engine type of MC, ME or ME-B design a 'Project Guide' has been prepared, describing the general technical features of that specific engine type, and also including some optional features and equipment.

The information is general, and some deviations may appear in a final engine documentation, depending on the content specified in the contract and on the individual licensee supplying the engine. The Project Guides comprise an extension of the general information in the Engine Selection Guide, as well as specific information on such subjects as:

- Engine Design
- Engine Layout and Load Diagrams, SFOC
- Turbocharger Selection & Exhaust Gas By-pass
- Electricity Production
- Installation Aspects
- List of Capacities: Pumps, Coolers & Exhaust Gas
- Fuel Oil
- Lubricating Oil
- Cylinder Lubrication
- Piston Rod Stuffing Box Drain Oil
- Central Cooling Water System
- Seawater Cooling
- Starting and Control Air
- Scavenge Air
- Exhaust Gas
- Engine Control System
- Vibration Aspects
- Monitoring Systems and Instrumentation
- Dispatch Pattern, Testing, Spares and Tools
- Project Support and Documentation.



## Installation Data Application

Additional customised information can be obtained from MAN Diesel & Turbo as project support. For this purpose, we have developed the CEAS application, by means of which specific calculations can be made during the project stage.

### The CEAS application

The CEAS application is found at [www.marine.man.eu](http://www.marine.man.eu) → 'Two-Stroke' → 'CEAS Engine Calculations'.

On completion of the CEAS application, a report is generated covering the following:

- Main engine room data
- Specified main engine and ratings
- Ambient reference conditions
- Expected SFOC, lube oil consumption, air and exhaust gas data
- Necessary capacities of auxiliary machinery (SMCR)
- Starting air system, engine dimensions, tanks, etc.
- Tables of SFOC and exhaust gas data
- Heat dissipation of engine
- Water condensation separation in air coolers
- Noise – engine room, exhaust gas, structure borne
- Preheating of diesel engine
- Alternative engines and turbochargers, further reading.

Links to related MAN Diesel & Turbo publications and papers are provided, too.

### Supplementary project data on request

Further to the data generated by the CEAS application, the following data are available on request at the project stage:

- Estimation of ship's dimensions
- Propeller calculation and power prediction
- Selection of main engine
- Main engines comparison
- Maintenance and spare parts costs of the engine
- Total economy – comparison of engine rooms
- Steam and electrical power – ships' requirement
- Utilisation of exhaust gas heat
- Utilisation of jacket cooling water heat, fresh water production
- Exhaust gas back pressure
- Layout/load diagrams of engine.

Contact MAN Diesel & Turbo, Copenhagen in this regard.



## Extent of Delivery

MAN Diesel & Turbo's 'Extent of Delivery' (EoD) is provided to facilitate negotiations between the yard, the engine maker, consultants and the customer in specifying the scope of supply for a specific project involving MAN B&W two-stroke engines.

We provide four different EoDs:

*EoD 70-50 MC-C Tier II Engine*

*EoD 46-35 MC-C Tier II Engines*

*EoD 98-50 ME/ME-C/ME-C-GI Tier II Engines*

*EoD 60-30 ME-B Tier II Engines*

These publications are available in print and at: [www.marine.man.eu](http://www.marine.man.eu) → 'Two-Stroke' → 'Extent of Delivery (EoD)'.

### Basic items and Options

The 'Extent of Delivery' (EoD) is the basis for specifying the scope of supply for a specific order.

The list consists of 'Basic' and 'Optional' items.

The 'Basic' items define the simplest engine, designed for unattended machinery space (UMS), without taking into consideration any further requirements from the classification society, the yard, the owner or any specific regulations.

The 'Options' are extra items that can be alternatives to the 'Basic', or additional items available to fulfil the requirements/functions for a specific project.

### Copenhagen Standard Extent of Delivery

At MAN Diesel & Turbo, Copenhagen, we base our first quotations on a 'mostly required' scope of supply. This is the so-called 'Copenhagen Standard Extent of Delivery', which is made up by options marked with an asterisk \* in the far left column in the EoD.

The Copenhagen Standard Extent of Delivery includes:

- Minimum of alarm sensors recommended by the classification societies and MAN Diesel & Turbo
- Moment compensator for certain numbers of cylinders
- MAN turbochargers
- The basic Engine Control System
- CoCoS-EDS ME Basic (for ME/ME-B/-GI only)
- Spare parts either required or recommended by the classification societies and MAN Diesel & Turbo
- Tools required or recommended by the classification societies and MAN Diesel & Turbo.

MAN Diesel & Turbo licencees may select a different extent of delivery as their standard.

### EoD and the final contract

The filled-in EoD is often used as an integral part of the final contract.

The final and binding extent of delivery of MAN B&W two-stroke engines is to be supplied by our licensee, the engine maker, who should be contacted in order to determine the execution for the actual project.



## Installation Documentation

When a final contract is signed, a complete set of documentation, in the following called 'Installation Documentation', will be supplied to the buyer by the engine maker.

The extent of Installation Documentation is decided by the engine maker and may vary from order to order.

As an example, for an engine delivered according to MAN Diesel & Turbo's 'Copenhagen Standard Extent of Delivery', the Installation Documentation is divided into the volumes 'A' and 'B':

- **4 09 602 Volume 'A'**  
Mainly comprises general guiding system drawings for the engine room
- **4 09 603 Volume 'B'**  
Mainly comprises specific drawings for the main engine itself.

Most of the documentation in volume 'A' are similar to those contained in the respective Project Guides, but the Installation Documentation will only cover the order-relevant designs.

The engine layout drawings in volume 'B' will, in each case, be customised according to the buyer's requirements and the engine maker's production facilities.

A typical extent of a set of volume 'A' and 'B' drawings is listed in the following.

For questions concerning the actual extent of Installation Documentation, please contact the engine maker.

## Engine-relevant documentation

### Engine data, on engine

External forces and moments  
Guide force moments  
Water and oil in engine  
Centre of gravity  
Basic symbols for piping  
Instrument symbols for piping  
Balancing

### Engine connections

Engine outline  
List of flanges/counterflanges  
Engine pipe connections

### Engine instrumentation

List of instruments  
Connections for electric components  
Guidance values automation, engine  
Electrical wiring

### Engine Control System

Engine Control System, description  
Engine Control System, diagrams  
Pneumatic system  
Speed correlation to telegraph  
List of components  
Sequence diagram

### Control equipment for auxiliary blower

Electric wiring diagram  
Auxiliary blower  
Starter for electric motors

### Shaft line, on engine

Crankshaft driving end  
Fitted bolts

### Turning gear

Turning gear arrangement  
Turning gear, control system  
Turning gear, with motor

### Spare parts

List of spare parts



**Engine paint**

Specification of paint

**Gaskets, sealings, O-rings**

Instructions

Packings

Gaskets, sealings, O-rings

**Engine pipe diagrams**

Engine pipe diagrams

Bedplate drain pipes

Instrument symbols for piping

Basic symbols for piping

Lubricating oil, cooling oil and hydraulic oil piping

Cylinder lubricating oil pipes

Stuffing box drain pipes

Cooling water pipes, air cooler

Jacket water cooling pipes

Fuel oil drain pipes

Fuel oil pipes

Control air pipes

Starting air pipes

Turbocharger cleaning pipe

Scavenge air space, drain pipes

Scavenge air pipes

Air cooler cleaning pipes

Exhaust gas pipes

Steam extinguishing, in scavenge air box

Oil mist detector pipes, if applicable

Pressure gauge pipes

**Engine room-relevant documentation****Engine data, in engine room**

List of capacities

Basic symbols for piping

Instrument symbols for piping

**Lubricating and cooling oil**

Lubricating oil bottom tank

Lubricating oil filter

Crankcase venting

Lubricating and hydraulic oil system

Lubricating oil outlet

**Cylinder lubrication**

Cylinder lubricating oil system

**Piston rod stuffing box**

Stuffing box drain oil cleaning system

**Seawater cooling**

Seawater cooling system

**Jacket water cooling**

Jacket water cooling system

Deaerating tank

Deaerating tank, alarm device

**Central cooling system**

Central cooling water system

Deaerating tank

Deaerating tank, alarm device

**Fuel oil system**

Fuel oil heating chart

Fuel oil system

Fuel oil venting box

Fuel oil filter

**Compressed air**

Starting air system

**Scavenge air**

Scavenge air drain system

**Air cooler cleaning**

Air cooler cleaning system

**Exhaust gas**

Exhaust pipes, bracing

Exhaust pipe system, dimensions

**Engine room crane**

Engine room crane capacity, overhauling space

**Torsiograph arrangement**

Torsiograph arrangement

**Shaft earthing device**

Earthing device

**Fire extinguishing in scavenge air space**

Fire extinguishing in scavenge air space

**Instrumentation**

Axial vibration monitor

**Engine seating**

Profile of engine seating

Epoxy chocks

Alignment screws

**Holding-down bolts**

Holding-down bolt

Round nut

Distance pipe

Spherical washer

Spherical nut

Assembly of holding-down bolt

Protecting cap

Arrangement of holding-down bolts

**Side chocks**

Side chocks

Liner for side chocks, starboard

Liner for side chocks, port side

**End chocks**

Stud for end chock bolt

End chock

Round nut

Spherical washer, concave

Spherical washer, convex

Assembly of end chock bolt

Liner for end chock

Protecting cap

**Engine top bracing**

Top bracing outline

Top bracing arrangement

Friction-materials

Top bracing instructions

Top bracing forces

Top bracing tension data

**Shaft line, in engine room**

Static thrust shaft load

Fitted bolt

**Power Take-Off**

List of capacities

PTO/RCF arrangement, if fitted

**Large spare parts, dimensions**

Connecting rod studs

Cooling jacket

Crankpin bearing shell

Crosshead bearing

Cylinder cover stud

Cylinder cover

Cylinder liner

Exhaust valve

Exhaust valve bottom piece

Exhaust valve spindle

Exhaust valve studs

Fuel valve

Main bearing shell

Main bearing studs

Piston complete

Starting valve

Telescope pipe

Thrust block segment

Turbocharger rotor

**Gaskets, sealings, O-rings**

Gaskets, sealings, O-rings

**Material sheets**

MAN Diesel & Turbo Standard Sheets Nos.:

- S19R
- S45R
- S25Cr1
- S34Cr1R
- C4

**Engine production and installation-relevant documentation****Main engine production records, engine installation drawings**

Installation of engine on board  
Dispatch pattern 1, or  
Dispatch pattern 2  
Check of alignment and bearing clearances  
Optical instrument or laser  
Reference sag line for piano wire  
Alignment of bedplate  
Piano wire measurement of bedplate  
Check of twist of bedplate  
Crankshaft alignment reading  
Bearing clearances  
Check of reciprocating parts  
Production schedule  
Inspection after shop trials  
Dispatch pattern, outline  
Preservation instructions

**Shop trials**

Shop trials, delivery test  
Shop trial report

**Quay trial and sea trial**

Stuffing box drain cleaning  
Fuel oil preheating chart  
Flushing of lubricating oil system  
Freshwater system treatment  
Freshwater system preheating  
Quay trial and sea trial  
Adjustment of control air system  
Adjustment of fuel pump  
Heavy fuel operation  
Guidance values automation

**Flushing procedures**

Lubricating oil system cleaning instruction

**Tools****Engine tools**

List of tools  
Outline dimensions, main tools

**Tool panels**

Tool panels

**Engine seating tools**

Hydraulic jack for holding down bolts  
Hydraulic jack for end chock bolts

**Auxiliary equipment**

Ordered auxiliary equipment



**MAN B&W**

---

---

Appendix

**A**

---

---

**MAN Diesel**



Symbols for Piping

No.	Symbol	Symbol designation	No.	Symbol	Symbol designation
<b>1</b>	<b>General conventional symbols</b>		2.14		Spectacle flange
1.1		Pipe	2.15		Bulkhead fitting water tight, flange
1.2		Pipe with indication of direction of flow	2.16		Bulkhead crossing, non-watertight
1.3		Valves, gate valves, cocks and flaps	2.17		Pipe going upwards
1.4		Appliances	2.18		Pipe going downwards
1.5		Indicating and measuring instruments	2.19		Orifice
<b>2</b>	<b>Pipes and pipe joints</b>		<b>3</b>	<b>Valves, gate valves, cocks and flaps</b>	
2.1		Crossing pipes, not connected	3.1		Valve, straight through
2.2		Crossing pipes, connected	3.2		Valves, angle
2.3		Tee pipe	3.3		Valves, three way
2.4		Flexible pipe	3.4		Non-return valve (flap), straight
2.5		Expansion pipe (corrugated) general	3.5		Non-return valve (flap), angle
2.6		Joint, screwed	3.6		Non-return valve (flap), straight, screw down
2.7		Joint, flanged	3.7		Non-return valve (flap), angle, screw down
2.8		Joint, sleeve	3.8		Flap, straight through
2.9		Joint, quick-releasing	3.9		Flap, angle
2.10		Expansion joint with gland	3.10		Reduction valve
2.11		Expansion pipe	3.11		Safety valve
2.12		Cap nut	3.12		Angle safety valve
2.13		Blank flange	3.13		Self-closing valve



No.	Symbol	Symbol designation	No.	Symbol	Symbol designation
3.14		Quick-opening valve	<b>4</b>	<b>Control and regulation parts</b>	
3.15		Quick-closing valve	4.1		Hand-operated
3.16		Regulating valve	4.2		Remote control
3.17		Kingston valve	4.3		Spring
3.18		Ballvalve (cock)	4.4		Mass
3.19		Butterfly valve	4.5		Float
3.20		Gate valve	4.6		Piston
3.21		Double-seated changeover valve	4.7		Membrane
3.22		Suction valve chest	4.8		Electric motor
3.23		Suction valve chest with non-return valves	4.9		Electro-magnetic
3.24		Double-seated changeover valve, straight	<b>5</b>	<b>Appliances</b>	
3.25		Double-seated changeover valve, angle	5.1		Mudbox
3.26		Cock, straight through	5.2		Filter or strainer
3.27		Cock, angle	5.3		Magnetic filter
3.28		Cock, three-way, L-port in plug	5.4		Separator
3.29		Cock, three-way, T-port in plug	5.5		Steam trap
3.30		Cock, four-way, straight through in plug	5.6		Centrifugal pump
3.31		Cock with bottom connection	5.7		Gear or screw pump
3.32		Cock, straight through, with bottom conn.	5.8		Hand pump (bucket)
3.33		Cock, angle, with bottom connection	5.9		Ejector
3.34		Cock, three-way, with bottom connection	5.10		Various accessories (text to be added)



No.	Symbol	Symbol designation	No.	Symbol	Symbol designation
5.11		Piston pump	7	<b>Indicating instruments with ordinary symbol designations</b>	
<b>6</b>	<b>Fittings</b>		7.1		Sight flow indicator
6.1		Funnel	7.2		Observation glass
6.2		Bell-mounted pipe end	7.3		Level indicator
6.3		Air pipe	7.4		Distance level indicator
6.4		Air pipe with net	7.5		Counter (indicate function)
6.5		Air pipe with cover	7.6		Recorder
6.6		Air pipe with cover and net			
6.7		Air pipe with pressure vacuum valve			
6.8		Air pipe with pressure vacuum valve with net			
6.9		Deck fittings for sounding or filling pipe			
6.10		Short sounding pipe with selfclosing cock			
6.11		Stop for sounding rod			

The symbols used are in accordance with ISO/R 538-1967, except symbol No. 2.19

178 30 61-4.1

Fig. A.01.01: Symbols for piping