

# CP Propeller Equipment

Contents	Page
<b>Introduction</b> .....	3
Propeller designation .....	3
<b>General Description</b> .....	5
Propeller equipment .....	6
<b>Mechanical Design</b> .....	8
Propeller type VBS .....	8
Propeller type VB .....	10
<b>Servo Oil System</b> .....	11
Hydra Pack .....	12
Lubricating oil system, VB .....	13
Lubricating oil system, VBS .....	13
<b>Propeller Shaft and Coupling Flange</b> .....	14
Coupling flange .....	14
Stern tube .....	15
Liners .....	15
Seals .....	15
Hydraulic bolts .....	16
Installation .....	16
<b>Propeller Blade Manufacturing and Materials</b> .....	17
Blade materials .....	17
<b>Optimizing Propeller Equipment</b> .....	18
Propeller design .....	18
Optimizing the complete propulsion plant .....	18
Hydrodynamic design of propeller blades .....	20
Cavitation .....	20
High skew .....	21
<b>Technical Calculation and Services</b> .....	22
Arrangement drawings .....	22
Plant information book .....	22
Alignment instructions .....	22
Torsional vibrations .....	22
Whirling and axial vibration calculations .....	23
<b>Main Dimensions</b> .....	25
Propeller equipment VB .....	25
Propeller equipment VBS .....	26
<b>Data Sheet for Propeller and Propulsion Plant</b> .....	27
<b>Instruction Manual</b> .....	29



## Introduction

The purpose of this manual is to act as a guide line in the project planning of the MAN B&W propeller equipment.

The manual gives a description of the basic design principles of the MAN B&W controllable pitch (CP) propeller equipment. It contains dimensional sketches, thereby making it possible to work out shaft line and engine room arrangement drawings. Furthermore, a guide line in some of the basic layout criteria is given.

Our design department is available with assistance concerning speed and bollard pull prognoses, determining power requirements from the propeller, as well as advice on more specific questions concerning installation and modes of operation.

All our product range is constantly under review, being developed and improved as needs and conditions dictate.

We therefore reserve the right to make changes to the technical specification and data without prior notice.

In connection with the propeller equipment the Alphatronic Control System can be used. Special literature concerning this field can be forwarded on request.

## Propeller designation

VB 640

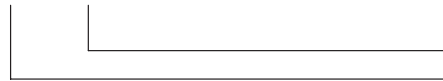

Diameter of propeller hub  
CP propeller with hydraulic servo motor  
in gearbox

VBS 1080



Diameter of propeller hub  
CP propeller with hydraulic servo motor  
in hub



## General Description

MAN B&W Alpha have manufactured more than 6,000 controllable pitch propellers of which the first was produced in 1902.

The basic design principle is well-proven, having been operated in all types of vessels including ferries, cruise and supply ships etc, many of which comply with high classification requirements.

Today the MAN B&W Alpha controllable pitch propeller equipment types VB and VBS are handling engine output up to 20,000 kW, fig 1.

Controllable pitch propellers can utilize full engine power by adjusting blade pitch irrespective of revolutions or conditions.

They offer not only maximum speed when free sailing, but also maximum power when towing, good manoeuvrability with quick response via the remote control system and high astern power.

These are just a few of many advantages achieved by controllable pitch propellers.

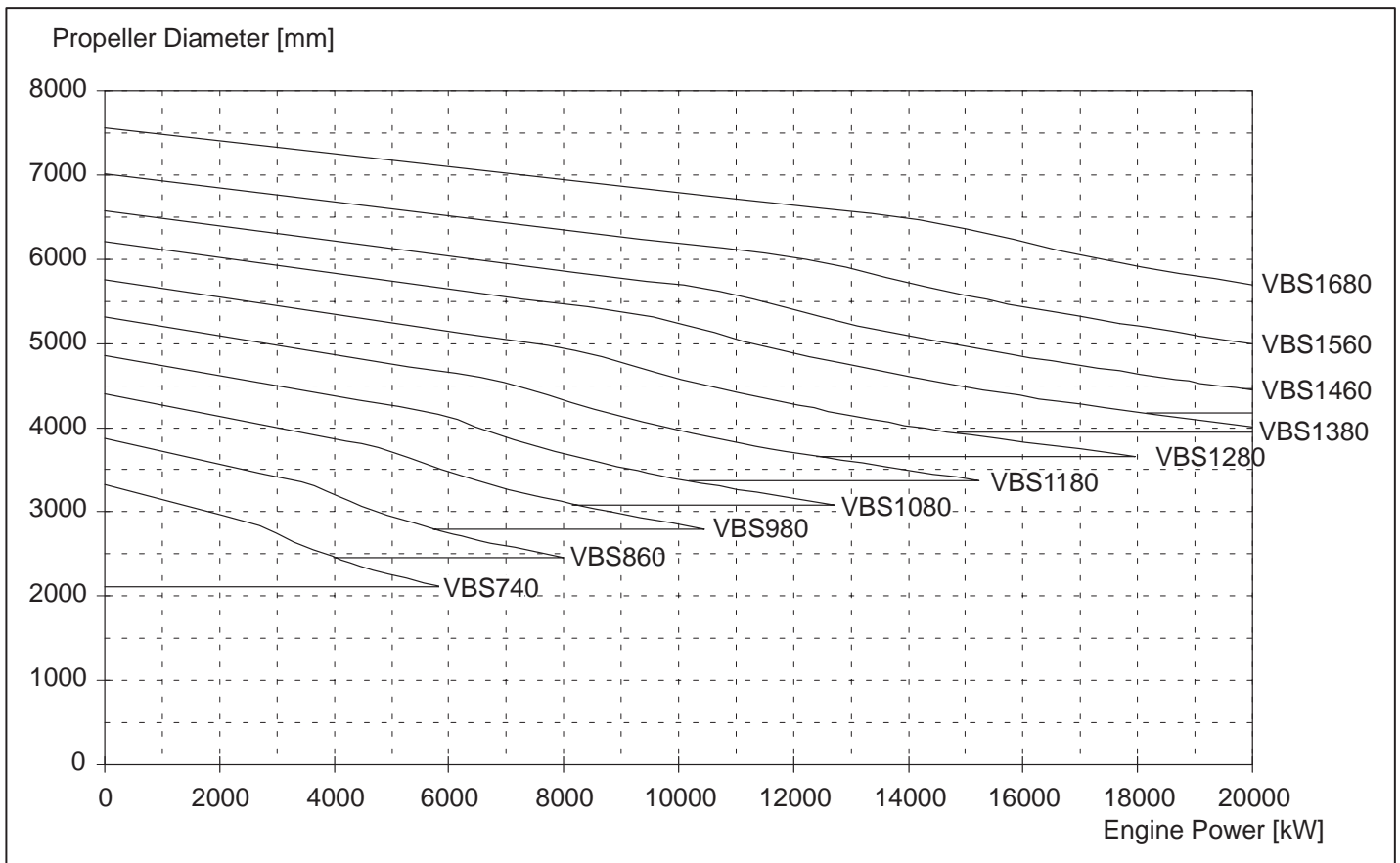

Fig 1: VBS propeller equipment programme for no ice class notation

### Propeller equipment

The standard propeller equipment comprises a four-bladed CP propeller complete with shafting, stern tube, outer and inboard seals, oil distributor and coupling flange.

The location of the hydraulic servo motor for controlling the pitch will depend on size and utilization of the propeller equipment.

### Propeller type VB

For propellers coupled to the MAN B&W Alpha gearbox the hydraulic servo motor is located in the gearbox controlling propeller pitch via a pitch control rod, fig 2.

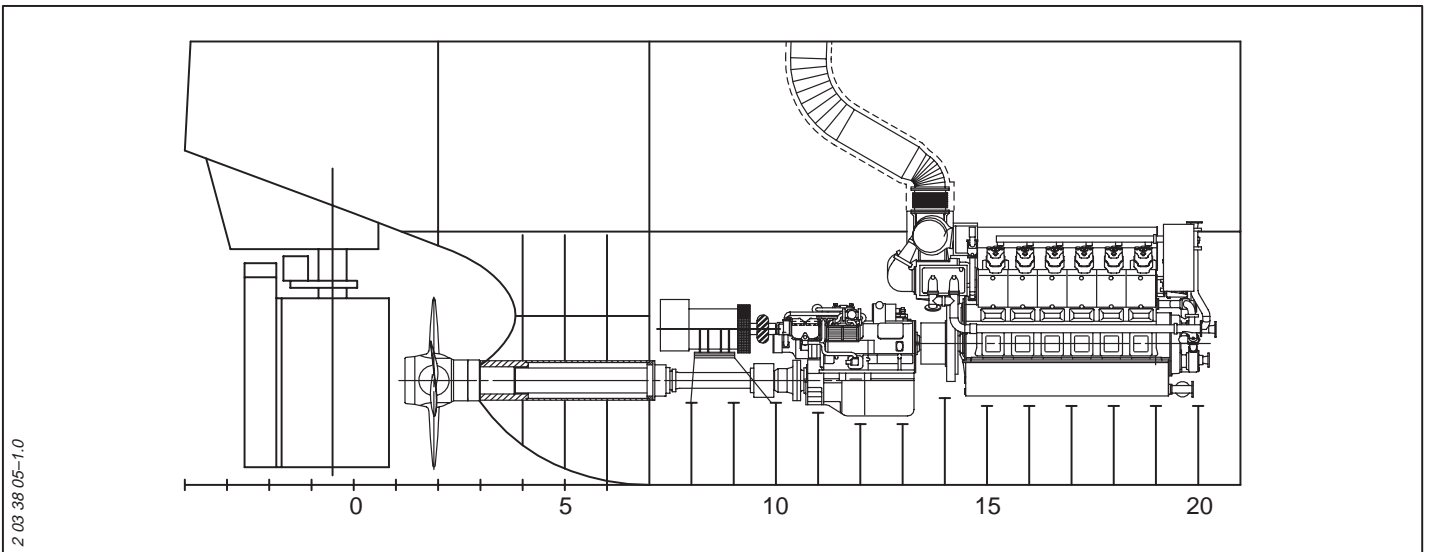

Fig 2: Propeller equipment type VB (12V23/30A, AMG 16, VB 640)

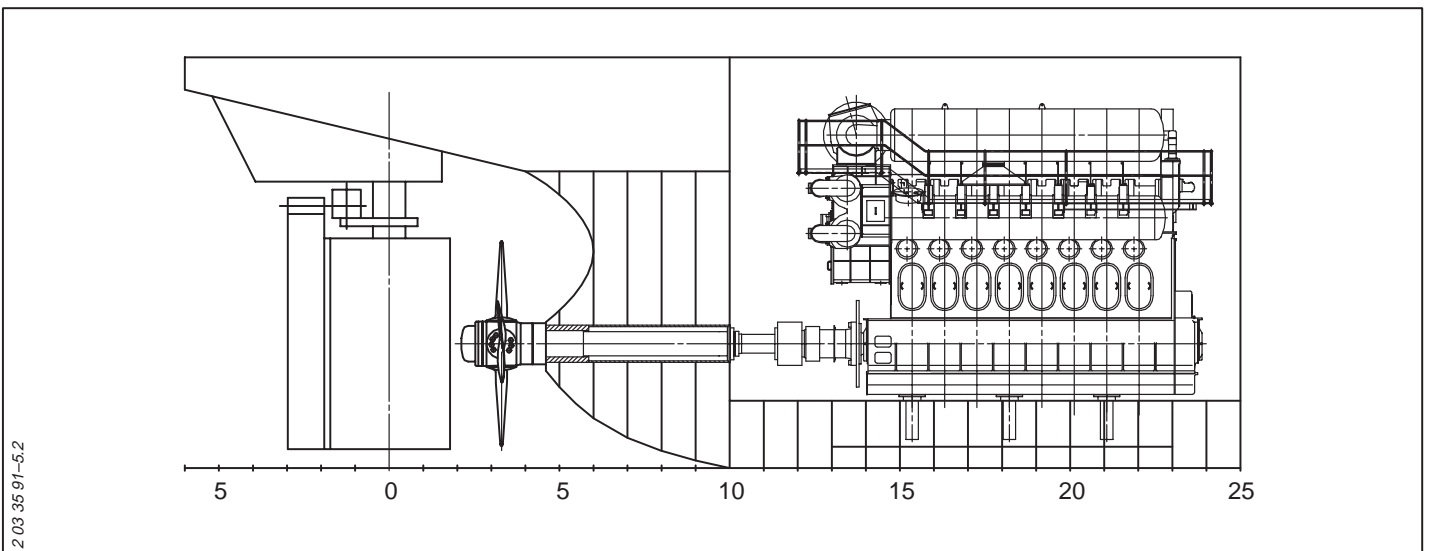

Fig 3: Propeller equipment type VBS (8L35MC, VBS 980)

**Propeller type VBS**

When using propeller hub diameters of 740 mm or larger, the hydraulic servo motor can be placed in the hub, figs 3, 4 and 5.

The system is featuring large servo piston diameter with low oil pressure and reacting forces, few components and reduction of overall installation length.

**Oil distributor**

For the VBS propeller equipment the oil distributor for the hydraulic servo motor can either be shaft mounted or mounted at the front end of the gear-box.

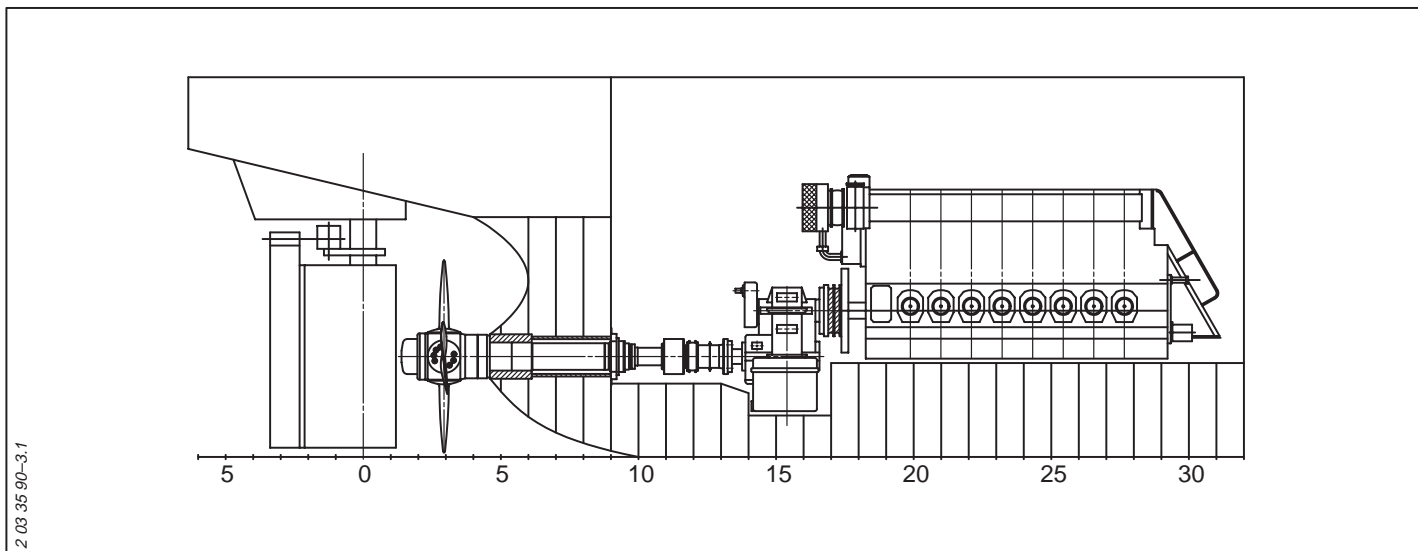

Fig 4: Propeller equipment type VBS (8L40/54, VBS 1280)

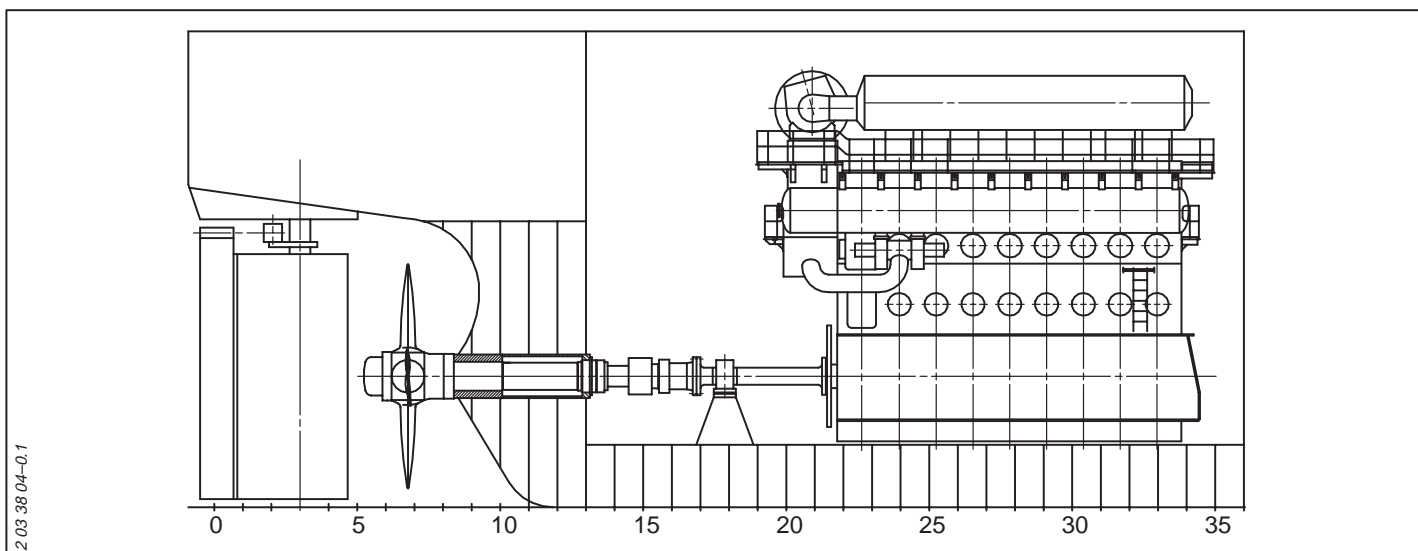

Fig 5: Propeller equipment type VBS (8S60MC, VBS 1680)

## Mechanical Design

### Propeller type VBS

In the propeller equipment type VBS the hydraulic servo motor for pitch setting is an integral part of the NiAl-bronze propeller hub. The design of the four-bladed CP propeller is shown in fig 6. The propeller hub is bolted to the flanged end of the tailshaft, which is bored to accommodate the servo oil and pitch feed-back rod.

The servo piston which is bolted to the pitch control head, forms the hydraulic servo motor together with the propeller cap.

The high pressure servo oil system at the aft end of the hub is completely iso-

lated from the pitch regulating mechanism and thus also from the blade flanges, which means that the blade sealings only are subjected to gravitation oil pressure.

By using a large servo piston diameter and balanced blade shapes, the oil pressure and reacting forces are minimized in the servo oil pressure space.

Blade sealing rings are placed between blade foot and blade flange, fig 7. A compressed O-ring presses a PTFE (teflon) slide ring against the blade foot. This design ensures maximum reliability and sealing, also under extreme abrasive wear conditions. For servicing and inspection of the internal parts the hub remains attached to the shaft

flange during disassembly thereby reducing time and need for heavy lifting equipment. Optionally an intermediate flange can be inserted, by which underwater replacement of propeller blades is possible.

A hydraulic tube, located inside the shafting, is connected to the piston. With hydraulic oil flowing through the tube, oil is given access into the after section of the propeller cap, displacing the servo piston forward, into an ahead pitch position. The displaced hydraulic oil from forward of the piston is returned via the annular space between the tube and shaft bore to the oil tank.

Reverting the flow directions will move the propeller in astern position.

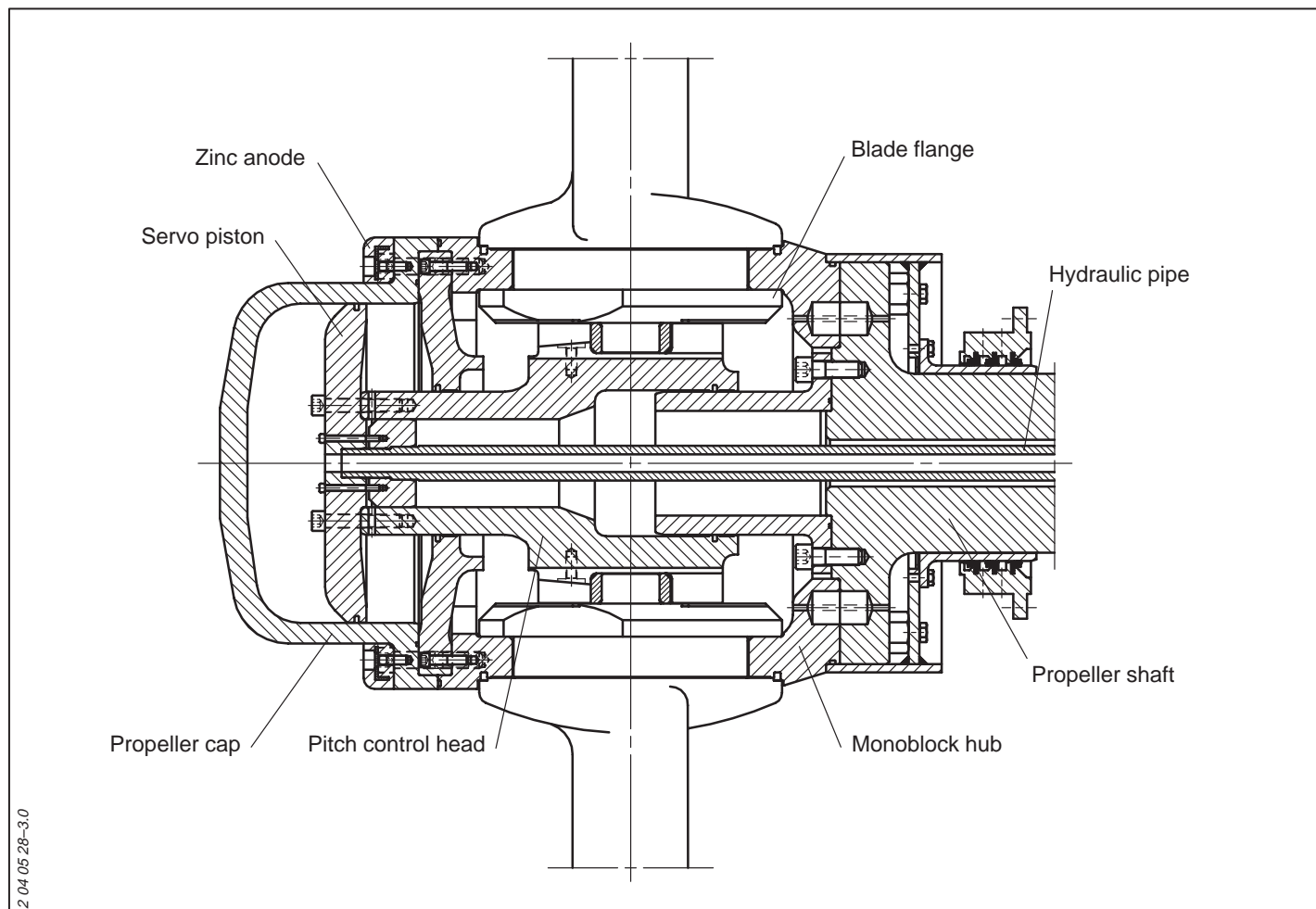

Fig 6: Propeller hub type VBS



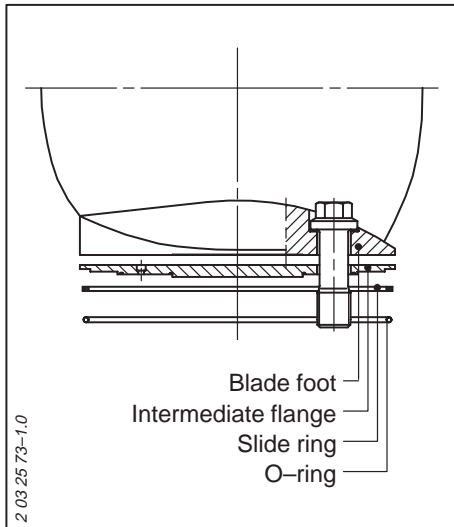

Fig 7: Blade sealing rings

### Oil distribution

The oil distribution to the hydraulic servo motor can be carried out in two different ways. For two-stroke plants the oil distributor is located at the shaft-line. For four-stroke plants with reduc-

tion gearboxes the oil distributor can either be placed at the front end of the gearbox or in the shaftline.

### Shaft mounted OD-ring

The shaft mounted unit consists of a coupling flange with OD-ring and pitch feed-back. Via the oil distribution ring, high pressure oil is connected to one side of the servo piston and the other side to the drain. The piston is hereby moved setting the desired propeller pitch. A feed-back ring is connected to the hydraulic pipe by slots in the coupling flange, fig 8. The feed-back ring actuates a displacement transmitter in the electrical pitch feed-back box which measures the actual pitch.

The inner surface of the oil distribution ring is lined with white-metal. The ring itself is split for exchange without withdrawal of the shaft or dismounting of the hydraulic coupling flange.

The sealing consists of mechanical throw-off rings which ensures that no

wear takes place and that sealing rings of V-lip-ring type or similar are unnecessary.

The oil distributor ring is prevented from rotating by a securing device comprising a steel ball located in the ring. Acceptable installation tolerances are ensured and movement of the propeller shaft remains possible.

In the event of failing oil pressure or fault in the remote control system, special studs can be screwed into the oil distribution ring hereby making manual oil flow control possible. A hold circuit will then maintain the chosen pitch.

### Gearbox mounted OD-box

For propulsion plants with reduction gearboxes the propeller equipment can be supplied with an oil distribution box mounted at the front-end of the gearbox. The OD-box incorporates an electric pitch feed-back.

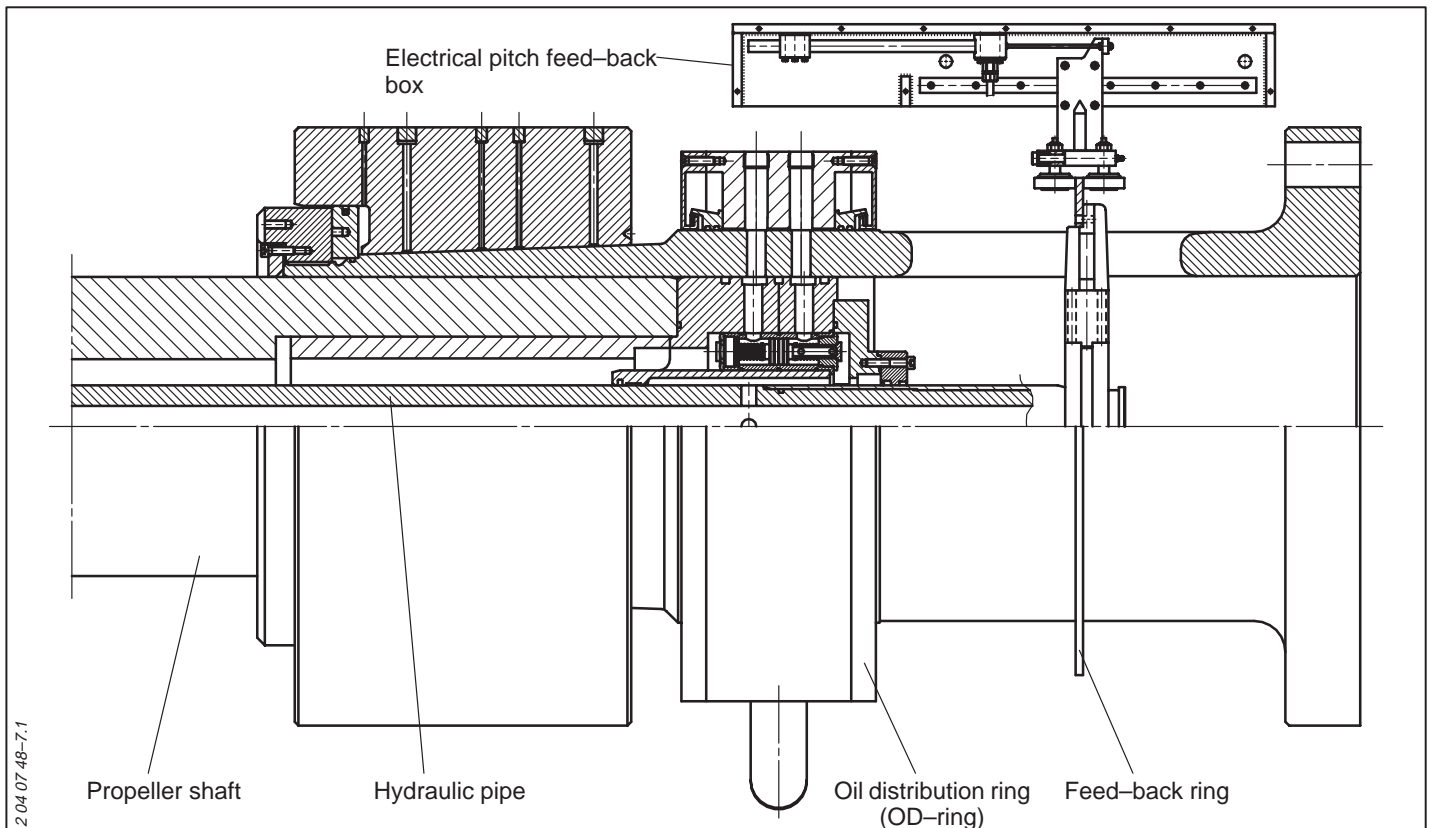

Fig 8: Coupling flange with OD-ring and pitch feed-back ring

### Propeller type VB

The VB propeller equipment is normally used for minor MAN B&W Alpha four-stroke propulsion plants in which the hydraulic servo motor for controlling the propeller pitch is located inside the Alpha gearbox.

The design of the VB propeller is shown in fig 9.

The propeller pitch, for the VB propeller equipment is controlled via a push/pull rod. The push/pull rod is passing

through a hollow bored shaft from a hydraulic servo motor located inside the gearbox to the pitch control mechanism placed inside the monobloc hub.

The pitch control mechanism is shown in fig 10.

The system uses the pin-in-slot mechanism, giving good pitch movement and control. This system ensures that the propeller pitch is proportional to the pitch control rod stroke. Pitch ahead is

applied when the pitch control yoke is moved aft.

The NiAl bronze hub is easily accessible from the aft end. On the cap a zinc anode is fitted to protect the propeller against galvanic corrosion.

Use of the largest possible blade flange diameter offers reduced bearing loads and ample room for securing bolts. More space is also available in order to accommodate large actuating pin diameters and stroke for the pitch control mechanism.

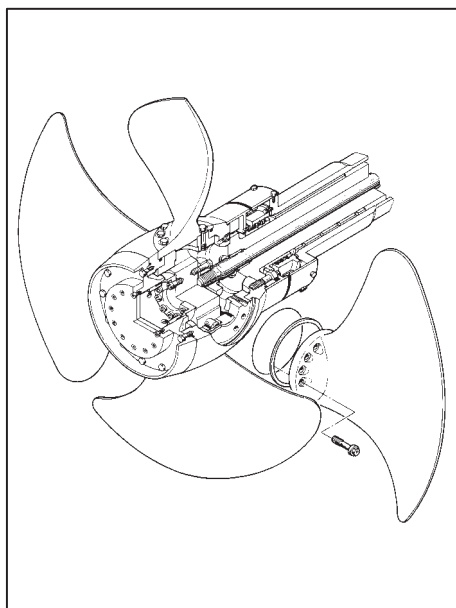

Fig 9: Propeller type VB

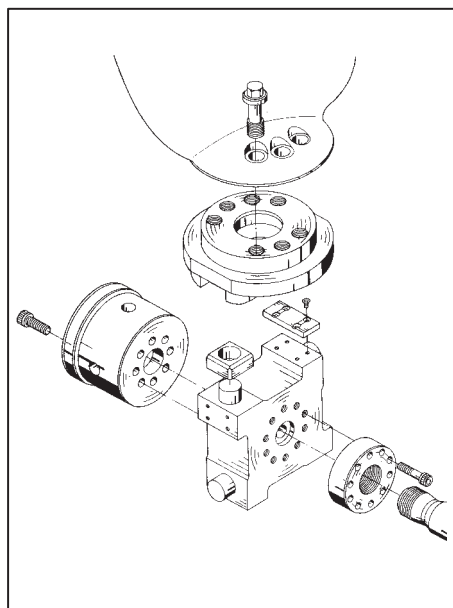

Fig 10: Pitch control mechanism

## Servo Oil System

The principle design of the servo oil systems for VBS (fig 11) and for VB (fig 12) is identical.

The VBS system consists of a servo oil tank unit – Hydra Pack, and a coupling flange with electrical pitch feed-back box and oil distributor ring.

For VB propeller equipment with Alpha reduction gearbox, the servo oil system is an integrated part of the gearbox. This means that the servo piston, pitch feed-back box and oil distributor ring are located inside the gearbox.

The electrical pitch feed-back box measures continuously the position of the pitch feed-back ring and compares this signal to the pitch order signal. If deviation occurs, a proportional valve is actuated.

Hereby high pressure oil is fed to one or the other side of the servo piston, via the oil distributor ring, until the desired propeller pitch has been reached.

The pitch setting is normally remote controlled, but local emergency control is possible.

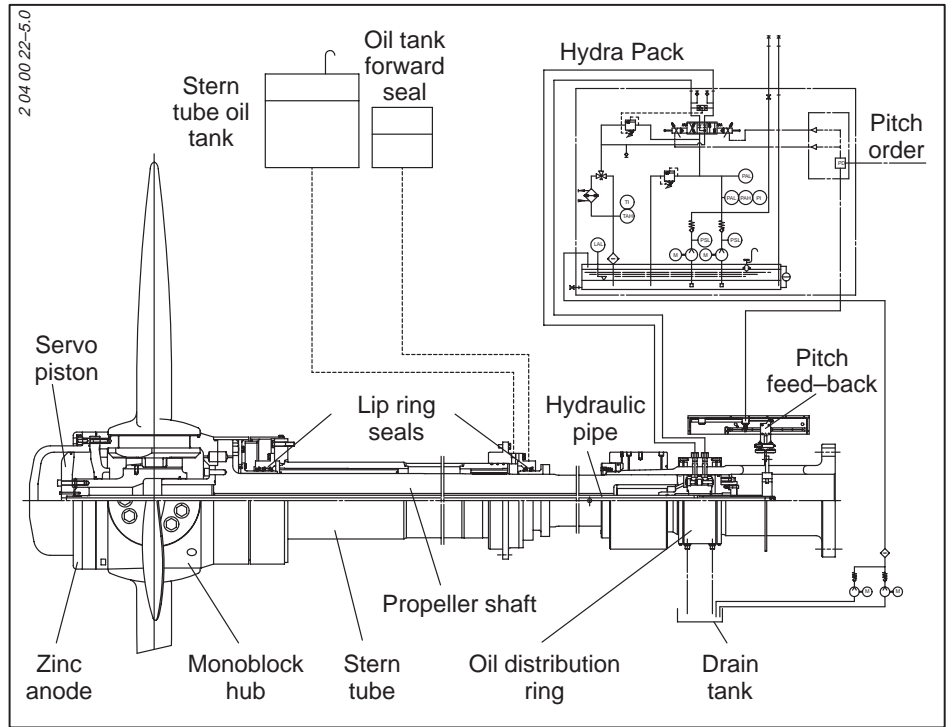

Fig 11: Propeller equipment type VBS

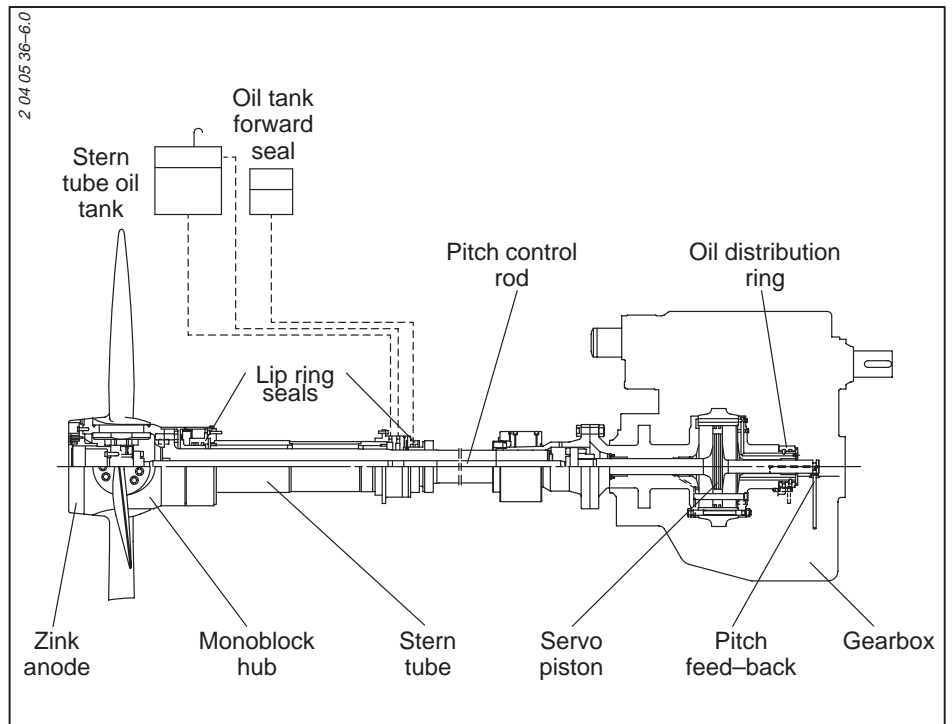

Fig 12: Propeller equipment type VB

## Hydra Pack

The servo oil unit – Hydra Pack (fig 13), consists of an oil tank with all components top mounted, to facilitate installation at yard.

Two electrically driven pumps draw oil from the oil tank through a suction filter and deliver high pressure oil to the proportional valve. One of the 2 pumps is in service during normal operation. A sudden change of manoeuvre will start up the second pump. A servo oil pressure adjusting valve ensures minimum servo oil pressure at any time hereby minimizing the electrical power consumption. Maximum system pressure is set on the safety valve.

The return oil is led back to the tank through a cooler and a paper filter. The servo oil unit is equipped with alarms according to the Classification Society as well as necessary pressure and temperature indication.

If the servo oil unit cannot be located with maximum oil level below the oil distribution ring the system must incorporate an extra, small drain tank complete with pump, located at a suitable level, below the oil distributor ring drain lines.

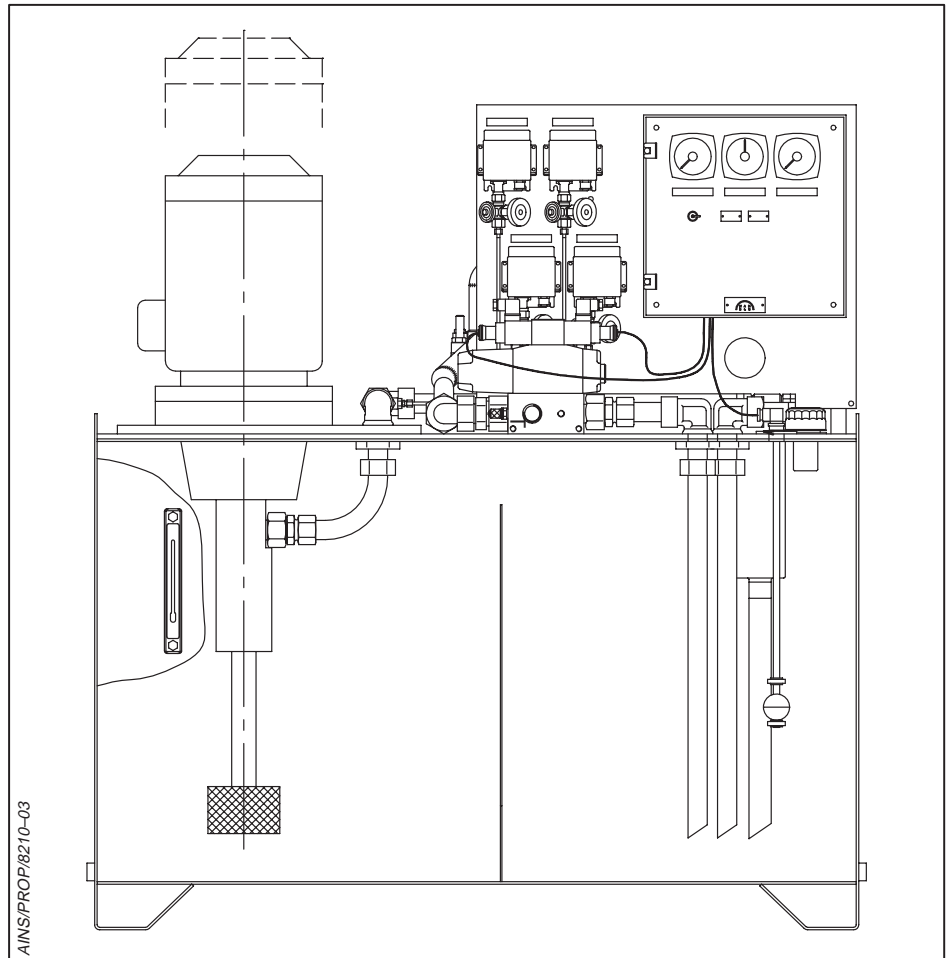

Fig 13: Servo oil unit – Hydra Pack

**Lubricating oil system, VB**

The VB propeller and stern tube have a common lubricating oil system, fig 14.

In order to prevent sea water penetration the system is kept under static pressure by the gravity tank placed above normal load water line in accordance with the stern tube seal manufacturer's recommendations.

Because of a pumping effect in the propeller hub during pitch changes, oil is circulated through propeller equipment and oil tank. Non return valves in hub

and at pitch control rod secure that the oil flow to the hub passes the stern tube journal bearings and further along the chromium steel journal to the blade actuator mechanism.

The return oil flows along the pitch control rod back to the lub oil tank.

The propeller hub is fitted with 2 plugs for draining and venting during docking.

The pitch control rod is lubricated with grease where intermediate shafts are fitted.

**Lubricating oil system, VBS**

As with the VB equipment the stern tube and hub lubrication is a common system. The stern tube is therefore kept under static oil pressure by a stern tube oil tank placed above sea level, see fig 11.

All MAN B&W propeller equipment with seals of the lip ring type operates on lub oil type SAE 30 – usually the same type of lubricating oil as used in the main engine and reduction gear.

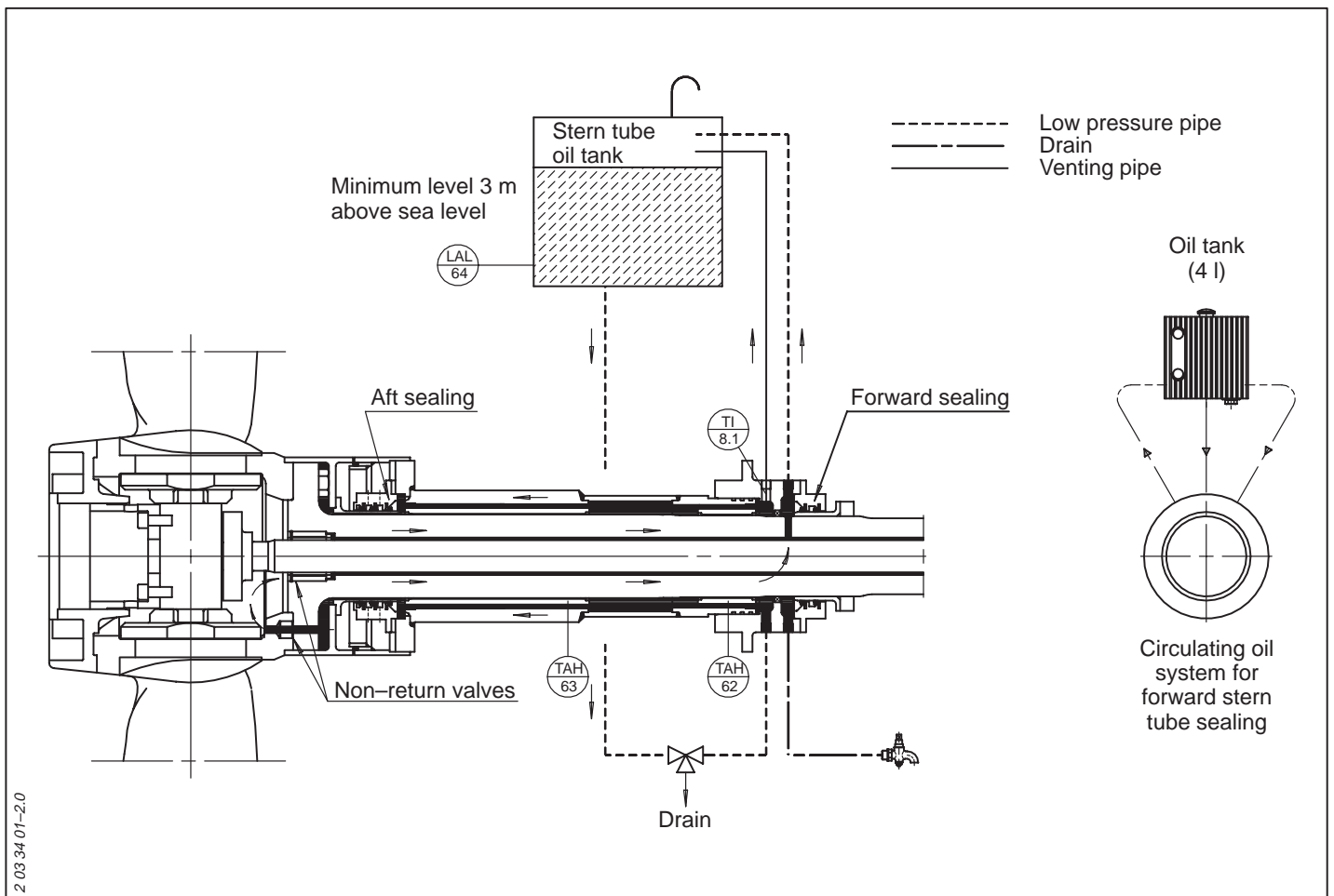

2 03 34 01-2.0

Fig 14: VB lubricating oil system

## Propeller Shaft and Coupling Flange

The tail shaft is made of forged steel normalized and stress relieved, fig 15 and table 1.

Material		Forged steel Ck45N
Yield strength	N/mm <sup>2</sup>	minimum 285
Tensile strength	N/mm <sup>2</sup>	570–690
Elongation	%	minimum 18
Impact strength Charpy V notch	Joules	minimum 17
Brinell hardness	HB	170–210

Table 1

The tail shaft is hollow-bored, housing either a pitch control rod or piping for pitch adjustment.

In plants with long shaftlines, the distance between the journal bearings can be estimated by means of the following formula provided the propeller speed is below 350 r/min.

$$L = 450 \sqrt{\text{shaft diameter (mm)}}$$

L = maximum bearing distance

### Coupling flange

A two-parted coupling flange is clamped on to the propeller shaft for flange diameters up to 475 mm. For couplings with flange diameters above 475 mm a special shrink fitted mounting is used, fig 16. High pressure oil of more than 2,000 bar is injected between the muff and the coupling flange by means of the injectors. By increasing the pressure in the annular space C, with the hydraulic pump, the muff is gradually pushed up the cone.

Longitudinal placing of the coupling flange as well as final push-up of the muff are marked on the shaft and the muff.

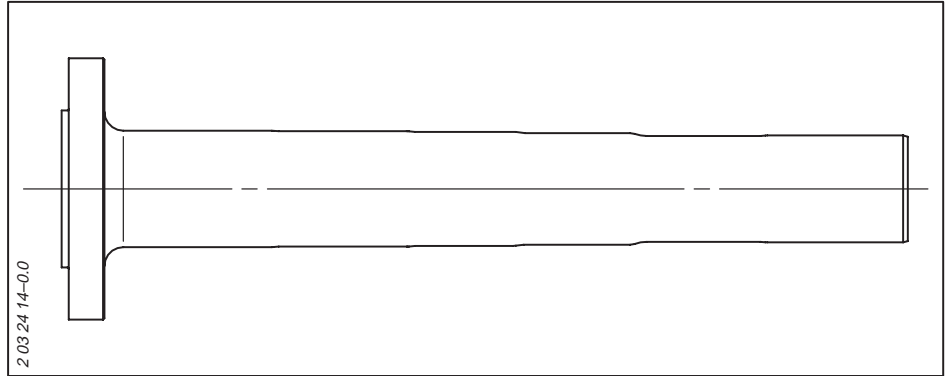

Fig 15: Tail shaft

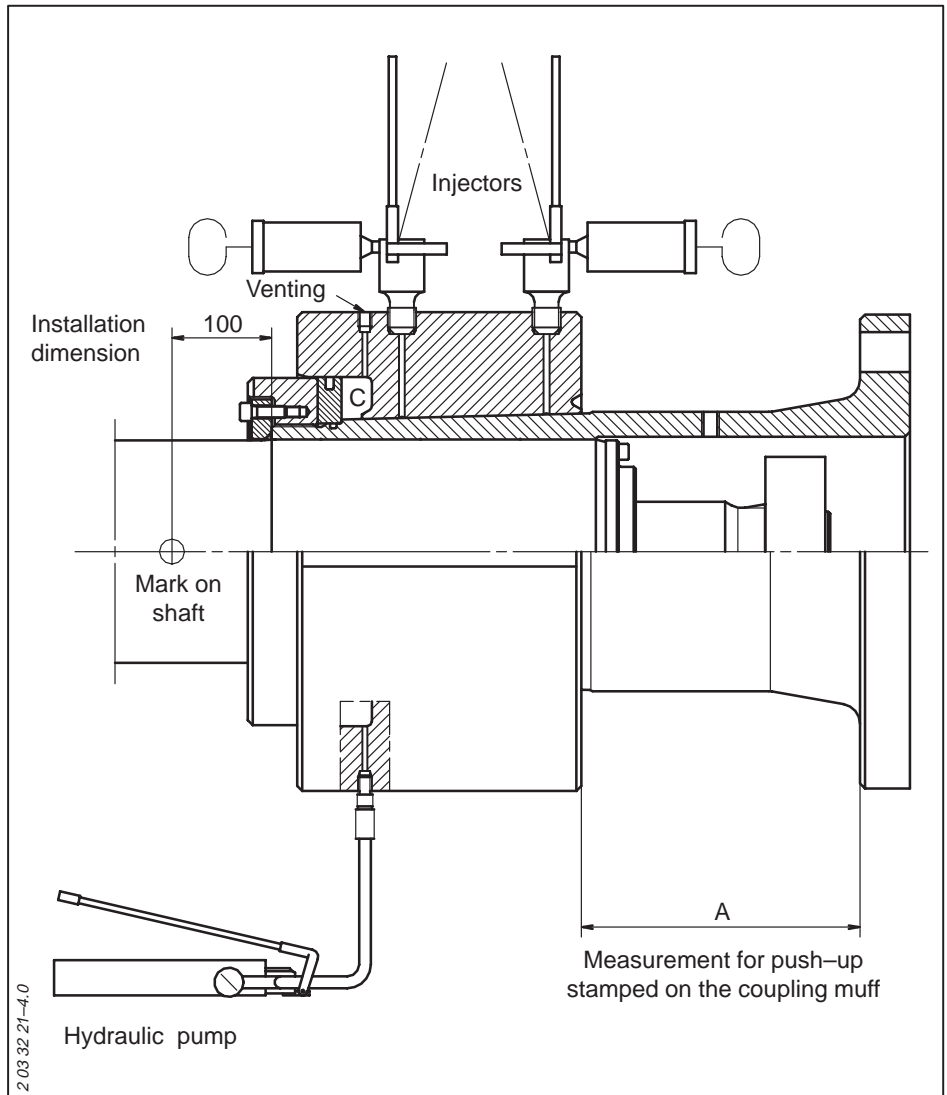

Fig 16: Shrink fitted coupling flange

**Stern tube**

The standard stern tube is designed to be installed from aft and is bolted to the stern frame boss, fig 17.

The forward end of the stern tube is supported by the welding ring. The oil box and the forward shaft seal are bolted onto the welding ring. This design allows thermal expansion/contraction of the stern tube and decreases the necessity for close tolerances of the stern tube installation length.

Normally the stern tube and the welding ring are supplied with 5 mm machining allowance for yard finishing.

The stern tube and welding ring can be supplied machined and finished, if required.

As an option the stern tube can be installed with epoxy resin.

**Liners**

The stern tube is provided with forward and aft white-metal liners, fig 18.

Sensors for bearing temperature can be mounted, if required.

A thermometer for the forward bearing is standard.

**Seals**

As standard, the stern tube is provided with forward and after stern tube seals of the lip ring type having three lip rings in the after seal and two lip rings in the forward seal, fig 19.

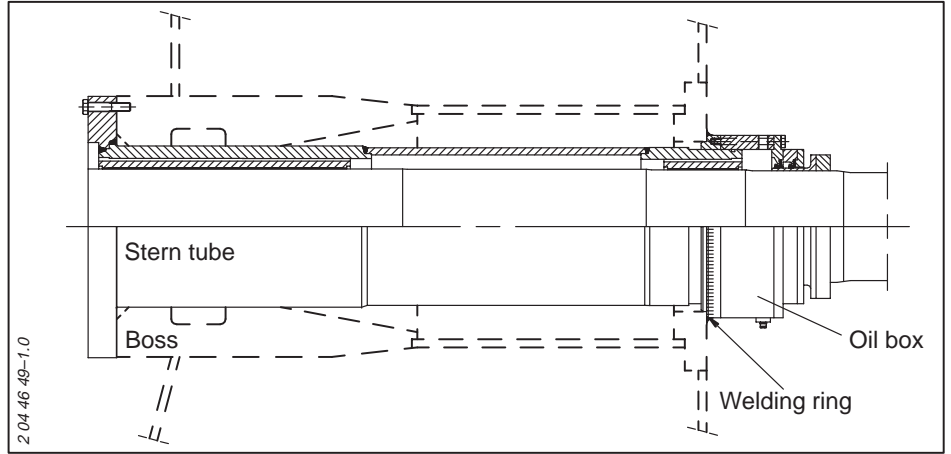

Fig 17: Standard stern tube – VBS

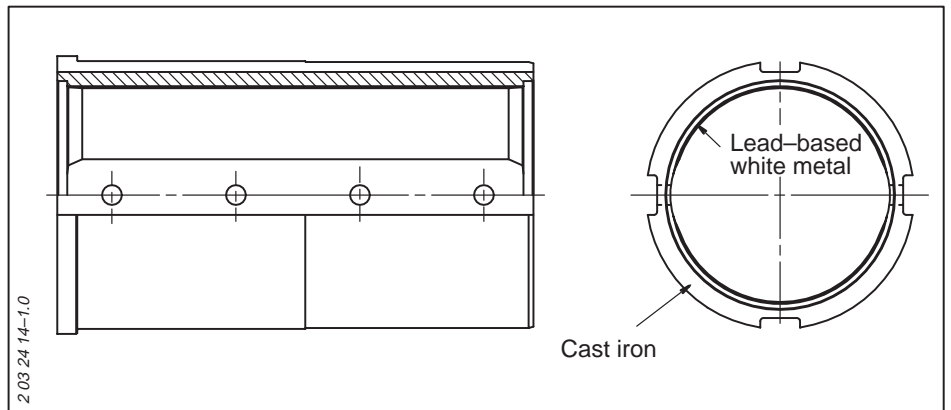

Fig 18: Stern tube white-metal liners

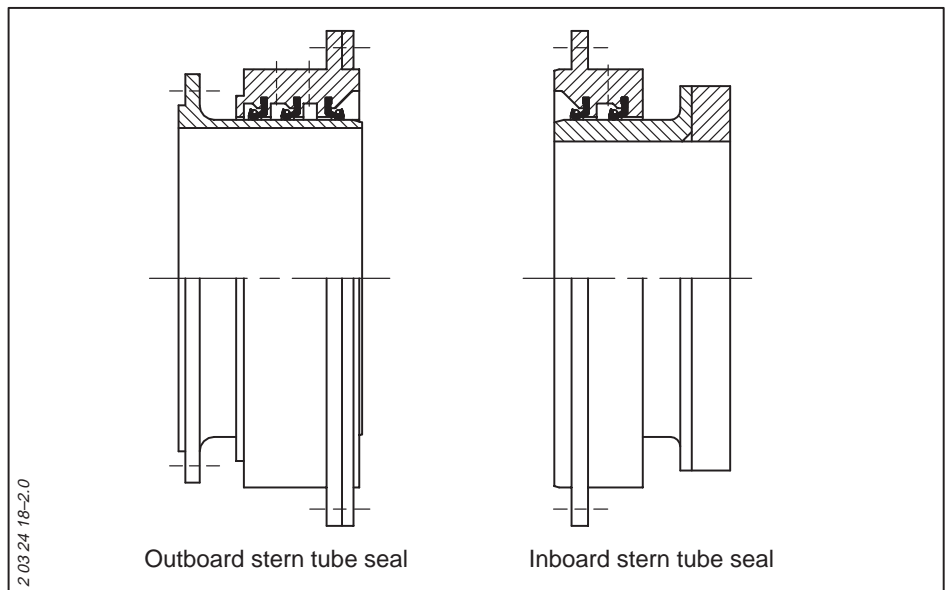

Fig 19: Stern tube seals

### Hydraulic bolts

The propeller equipment can be supplied with hydraulic bolts for easy assembly and disassembly between propeller shaft line, intermediate shafts and main engine flywheel, fig 20.

### Installation

Installation of propeller equipment into the ship hull can be done in many different ways as both yards and owners have different requirements of how to install and how to run the propeller equipment. Other designs of stern tube and/or shaft sealing may be preferred. MAN B&W Alpha are available with alternatives to meet specific wishes or design requirements.

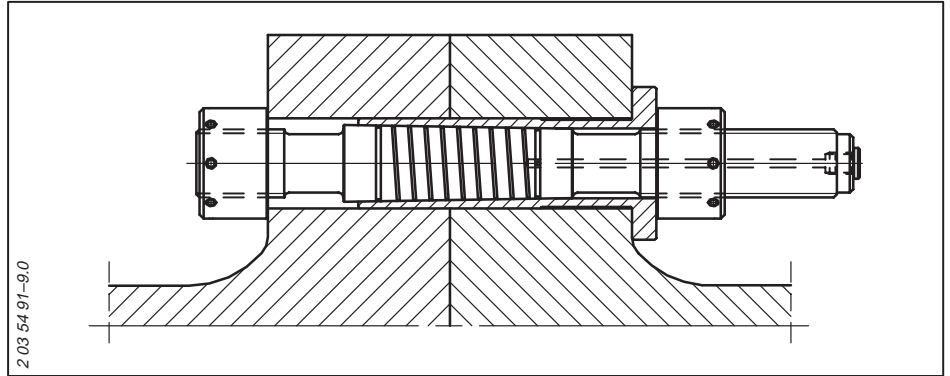

*Fig. 20 Hydraulic bolt*



## Propeller Blade Manufacturing and Materials

The international standard organization has introduced a series of manufacturing standards in compliance with which propellers have to be manufactured (ISO 484). The accuracy class is normally selected by the customer and the table below describes the range of manufacturing categories.

Class	Manufacturing accuracy
S	Very high accuracy
I	High accuracy
II	Medium accuracy
III	Wide tolerances

At MAN B&W Alpha the propeller blades are checked by computerized four-axis measuring equipment.

If no class is specified, the propeller blades will be manufactured according to class I but with surface roughness according to Class S.

## Blade materials

Propeller blades are made of either NiAl-bronze (NiAl) or stainless steel (CrNi). The mechanical properties of each material at room temperature are:

Material		NiAl	CrNi
Yield strength	N/mm <sup>2</sup>	min 250	min 380
Tensile strength	N/mm <sup>2</sup>	590–780	600–790
Elongation	%	min 16	min 19
Impact strength Charpy V notch	Joules	30	21
Brinell Hardness	HB	min 150	240–300

Both materials have high resistance against cavitation erosion. The fatigue characteristics in a corrosive environment are better for NiAl than for CrNi.

Propeller blades are, to a large degree, exposed to cyclically varying stresses. Consequently, the fatigue material strength is of decisive importance.

The dimensioning of a propeller blade according to the Classification Societies will give a 10% higher thickness for the CrNi compared to NiAl in order to obtain the same fatigue strength.

As an example the difference in thickness and weight for a propeller blade for engine type MAN B&W 6S35MC (4,200 kW at 170 r/min) is stated in table 2.

CrNi-steel requires thicker blades than NiAl-bronze, which is unfortunate from the propeller theoretical point of view (thicker = less efficiency). Additionally, the CrNi is more difficult to machine than NiAl.

For operation in ice the CrNi material will be able to withstand a higher force before bending due to its higher yield strength and for prolonged operations in shallow water the higher hardness makes it more resistant to abrasive wear from sand.

The final selection of blade and hub material depends on the operating condition of the vessel. In general terms the NiAl material is preferable for ordinary purposes whereas CrNi could be an attractive alternative for non-ducted propellers operating in heavy ice or dredgers and vessels operating in shallow waters.

Ice class		C		1A*	
Material		NiAl	CrNi	NiAl	CrNi
Thickness at $r/R = 0.35$	mm	132	146	169	187
Thickness at $r/R = 0.60$	mm	71	78	90	100
Thickness at $r/R = 1.00$	mm	0	0	15	13
Blade weight	kg	729	877	952	1053

Table 2

Classification society: Det Norske Veritas

## Optimizing Propeller Equipment

### Propeller design

The design of a propeller for a vessel can be categorized in two parts:

- Optimizing the complete propulsion plant
- Hydrodynamic design of propeller blades.

### Optimizing the complete propulsion plant

The design of the propeller, giving regard to the main variables such as diameter, speed, area ratio etc, is determined by the requirements for maximum efficiency and minimum vibrations and noise levels.

The chosen diameter should be as large as the hull can accommodate, allowing the propeller speed to be selected according to optimum efficiency. The optimum propeller speed corresponding to the chosen diameter can be found in fig 21 for a given reference condition (ship speed 12 knots and wake fraction 0.25).

For ships often sailing in ballast condition, demands of fully immersed propellers may cause limitations in propeller diameter. This aspect must be considered in each individual case.

To reduce emitted pressure impulses and vibrations from the propeller to the hull, MAN B&W Alpha recommend a minimum tip clearance as shown in fig 22.

The lower values can be used for ships with slender aft body and favourable inflow conditions whereas full after body ships with large variations in wake field require the upper values to be used.

In twin screw ships the blade tip may protrude below the base line.

The operating data for the vessel is essential for optimizing the propeller successfully, therefore it is of great importance that such information is available.

To ensure that all necessary data are known by the propeller designer, the data sheets on page 27 and 28, should be completed.

For propellers operating under varying conditions (service, max or emergency speeds, alternator engaged/disengaged) the operating time spent in each mode should be given.

This will provide the propeller designer with the information necessary to design a propeller capable of delivering the highest overall efficiency.

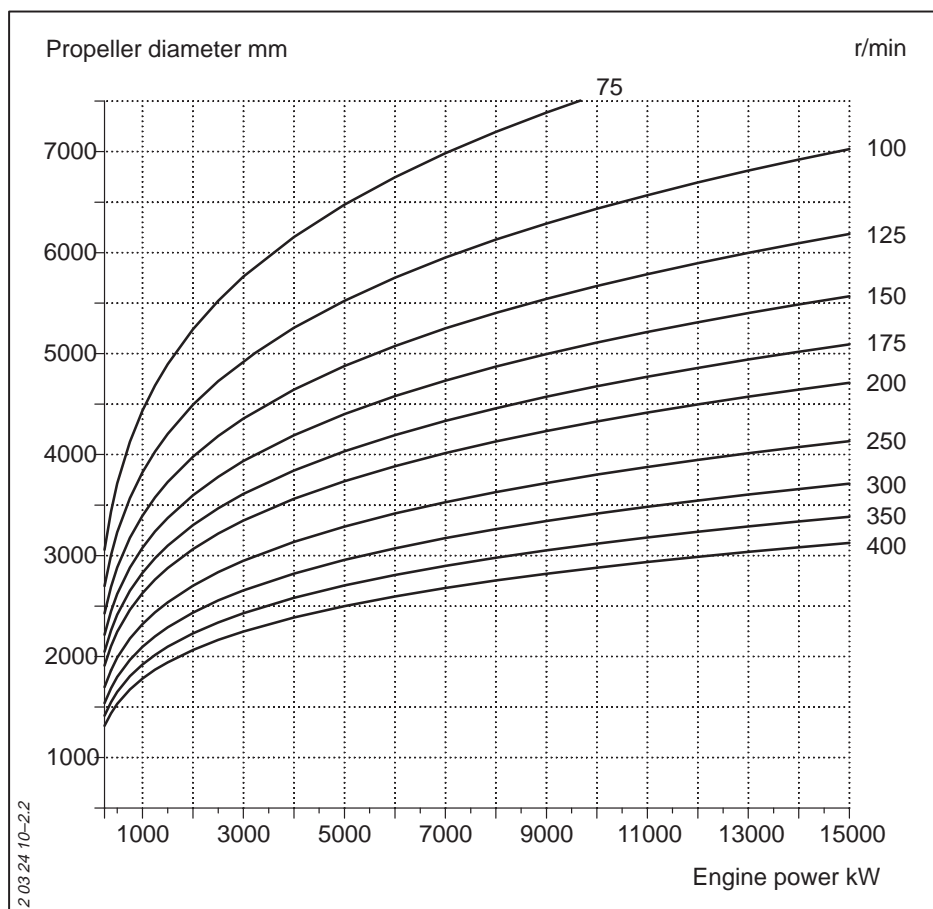
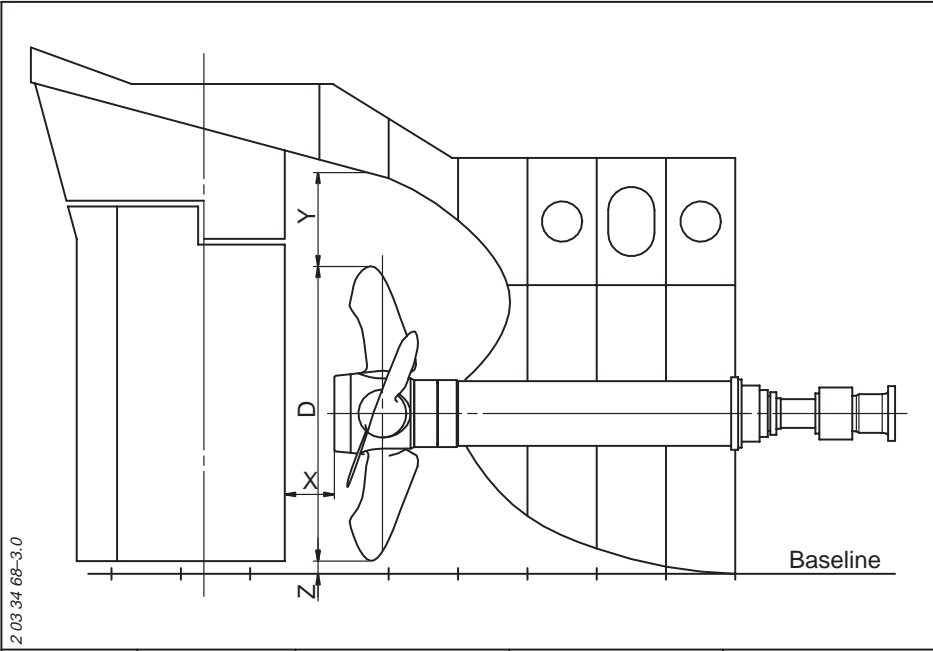

Fig 21: Optimum propeller diameter



Hub	Dismantling of cap X mm	High skew propeller Y	Non-skew propeller Y	Baseline clearance Z mm
VB 480	75	15–20% of D	20–25% of D	Minimum 50–100
VB 560	100			
VB 640	115			
VB 740	115			
VB 860	135			
VB 980	120			
VBS 740	225			
VBS 860	265			
VBS 980	300			
VBS 1080	330			
VBS 1180	365			
VBS 1280	395			
VBS 1380	420			
VBS 1460	450			
VBS 1560	480			
VBS 1680	515			

Fig 22: Recommended tip clearance

To assist a customer in selecting the optimum propulsion system, MAN B&W Alpha are able of performing speed prognosis (fig 23), fuel oil consumption calculations (fig 24) and towing force calculations (fig 25). Various additional alternatives may also be investigated (ie different gearboxes, propeller equipment, nozzles against free running propellers, varying draft and trim of vessel, etc).

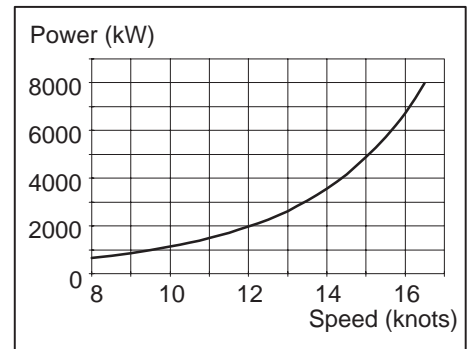

Fig 23: Speed prognosis

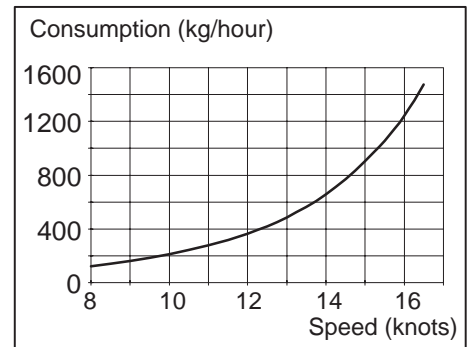

Fig 24: Fuel oil consumption

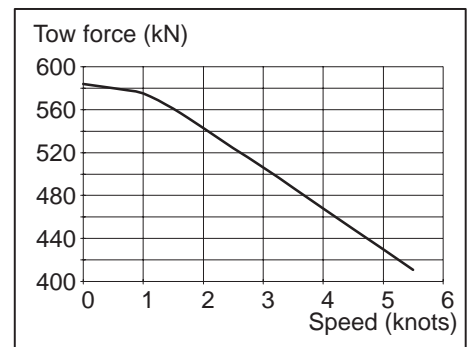

Fig 25: Tow force

## Hydrodynamic design of propeller blades

The propeller blades are computer designed, based on advanced hydrodynamic theories, practical experience and model tests at various hydrodynamic institutes.

The blades are designed specially for each hull and according to the operating conditions of the vessel.

High propulsion efficiency, suppressed noise levels and vibration behaviour are the prime design objectives.

Propeller efficiency is mainly determined by diameter and the corresponding optimum speed. To a lesser, but still important degree, the blade area, the pitch and thickness distribution also have an affect on the overall efficiency.

Blade area is selected according to requirements for minimum cavitation, noise and vibration levels.

To reduce the extent of cavitation on the blades even further, the pitch distribution is often reduced at the hub and tip, fig 26.

Care must be taken not to make excessive pitch reduction which will effect the efficiency.

Thickness distribution is chosen according to the requirements of the Classification Societies for unskewed propellers.

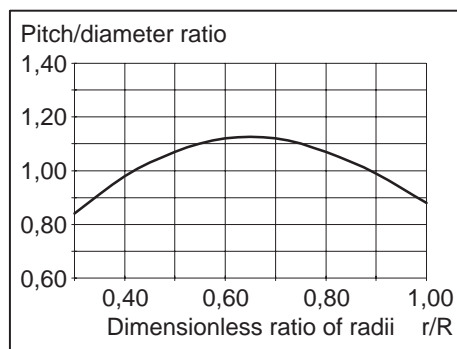

Fig 26: Pitch distribution along radius

## Cavitation

Cavitation is associated with generation of bubbles caused by a decrease in the local pressure below the prevailing saturation pressure. The low pressure can be located at different positions on the blade as well as in the trailing wake.

When water passes the surface of the propeller it will experience areas where the pressure is below the saturation pressure eventually leading to generation of air bubbles. Further down stream the bubbles will enter a higher pressure region where the bubbles will collapse and cause noise and vibrations to occur, in particular if the collapse of bubbles takes place on the hull surface.

Three main types of cavitation exist – their nature and position on the blades can be characterized as:

- **Sheet cavitation on suction side (Fig 27)**

The sheet cavitation is generated at the leading edge due to a low pressure peak in this region. If the extent of cavitation is limited and the clearance to the hull is sufficient, no severe noise/vibration will occur. In case the cavitation extends to more than half of the chord length, it might develop into cloud cavitation. Cloud cavitation often leads to cavitation erosion of the blade and should therefore be avoided. Sheet cavitation in the tip region can develop into a tip vortex which will travel down stream. If the tip vortex extends to the rudder, it may cause erosion.

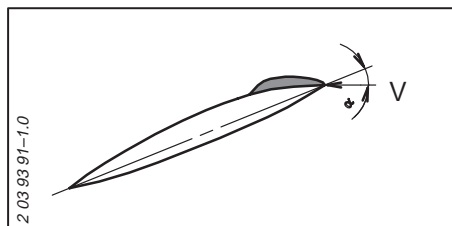

Fig 27: Suction side (sheet cavitation)

- **Bubble cavitation (Fig 28)**

In case the propeller is overloaded – ie the blade area is too small compared to the thrust required – the mid chord area will be covered by cavitation. This type of cavitation is generally followed by cloud cavitation which may lead to erosion. Due to this it must be avoided in the design.

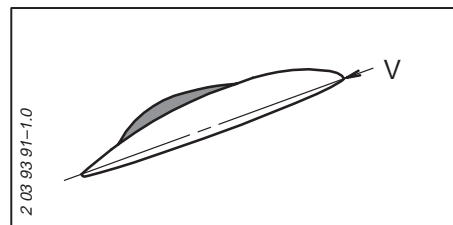

Fig 28: Suction side (bubble cavitation)

- **Sheet cavitation on pressure side (Fig 29)**

This type of cavitation is of the same type as the suction side sheet cavitation but the generated bubbles have a tendency to collapse on the blade surface before leaving the trailing edge. The danger of erosion is eminent and the blade should therefore be designed without any pressure side cavitation.

By using advanced computer programmes the propeller designs supplied by MAN B&W Alpha will be checked for the above cavitation types and designed to minimize the extent of cavitation as well as avoiding harmful cavitation erosion.

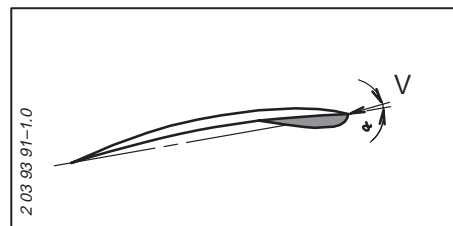

Fig 29: Pressure side (sheet cavitation)

For each condition and all angular positions behind the actual hull, the flow around the blade is calculated. The extent of cavitation is evaluated with respect to noise and vibration, fig 30.

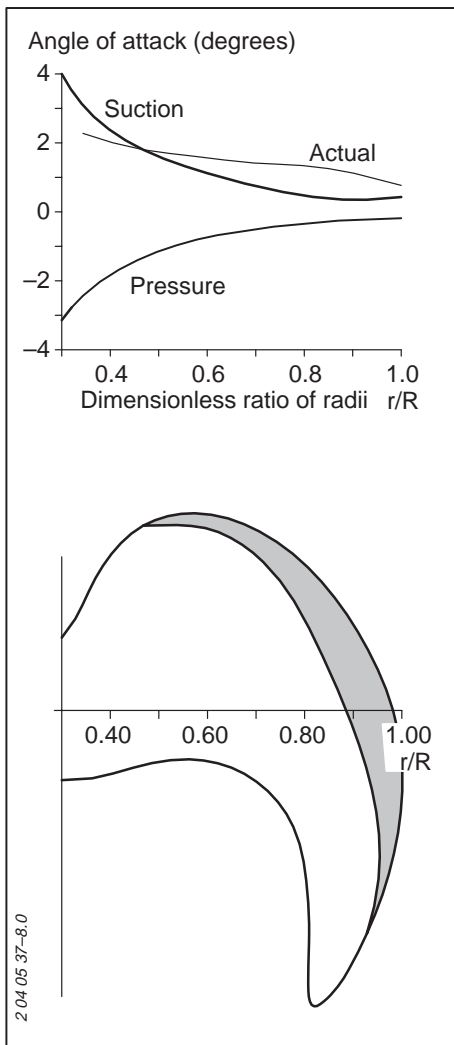

Fig 30: Cavitation chart and extension of sheet cavitation – suction side

**High skew**

To suppress cavitation-induced pressure impulses even further, a high skew design can be supplied, fig 31. By skewing the blade it is possible to reduce the vibration level to less than 30% of an unskewed design. Because skew does not affect the propeller efficiency, it is almost standard design on vessels where low vibration levels are required.

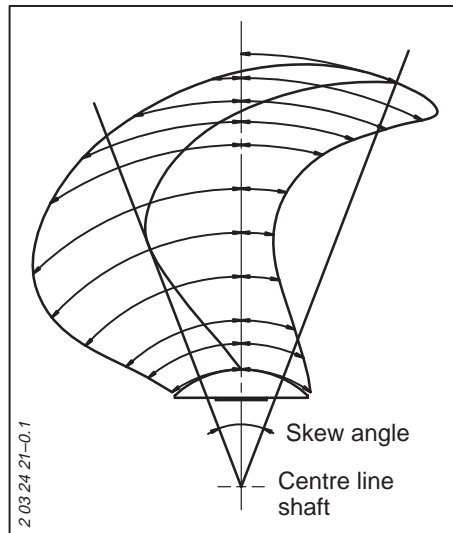

Fig 31: High skew design

Today, the skew distribution is of the “balanced” type, which means that the blade chords at the inner radii are skewed (moved) forward, while at the outer radii the cords are skewed aft. By designing blades with this kind of skew distribution, it is possible to control the spindle torque and thereby minimize the force on the actuating mechanism inside the propeller hub, fig 32.

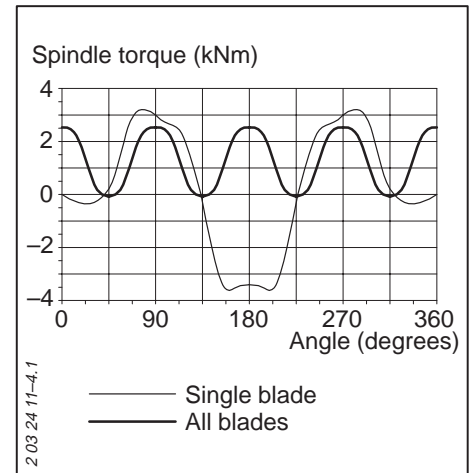

Fig 32: Spindle torque

For high skew designs, the normal simple beam theory does not apply and a more detailed finite element analysis must be carried out, fig 33.

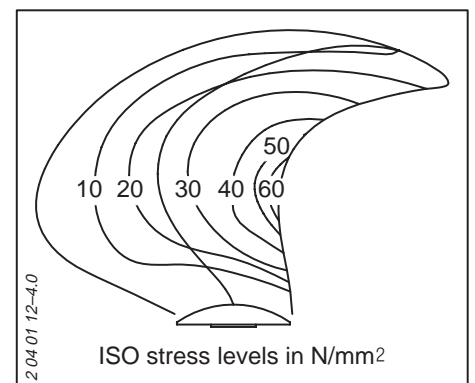

Fig 33: Finite element calculation of propeller blade

## Technical Calculation and Services

### Arrangement drawings

Provided MAN B&W Alpha have adequate information on the ship hull, an arrangement drawing showing a suitable location of the propulsion plant in the ship can be carried out with due consideration to a rational lay-out of propeller shaft line and bearings.

In order to carry out the above arrangement drawing MAN B&W Alpha need the following drawings:

- Ship lines plan
- Engine room arrangement
- General arrangement

Moreover, to assist the consulting firm or shipyard in accomplishing their own arrangement drawings, drawings of our propeller programme can be transmitted by E-mail or a disk can be forwarded by regular post. The disks are compatible with various CAD programmes. Should you require further information, please contact MAN B&W Alpha.

### Plant information book

After the contract documentation has been completed a Plant Information Book will be forwarded. This book will comprise all necessary detailed drawings, specifications and installation instructions for our scope of supply.

CAE programmes are used for making alignment calculations, epoxy chock calculations, torsional vibration calculations etc. In the following a brief description is given of some of our CAE programmes and software service.

### Alignment instructions

For easy alignment of the propeller shaft line, alignment calculations are made and a drawing with instructions is given in the Plant Information Book, fig 34.

The alignment calculations ensure acceptable load distribution of the stern tube bearings and shaft bearings.

### Torsional vibrations

A comprehensive analysis of the torsional vibration characteristics of the complete propulsion plant is essential to avoid damage to the shafting due to fatigue failures.

Based on vast experience with torsional vibration analysis of MAN B&W two and four-stroke propulsion plants, the VBS and VB propeller equipment is designed with optimum safety against premature failure due to fatigue. Stress raisers in the shafting or servo unit are minimized using finite element techniques.

When the propeller is delivered with a MAN B&W engine a complete torsional vibration analysis in accordance with the Classification Society rules is performed. This includes all modes of operation including simulation of engine misfire.

When the total propulsion plant is designed and manufactured by MAN B&W, the optimum correlation between the individual items exists. The extensive know-how ensures that the optimum solution is found as regards minimizing stresses in connection with torsional vibration calculations. Fig 35 shows the result of a torsional vibration calculation.

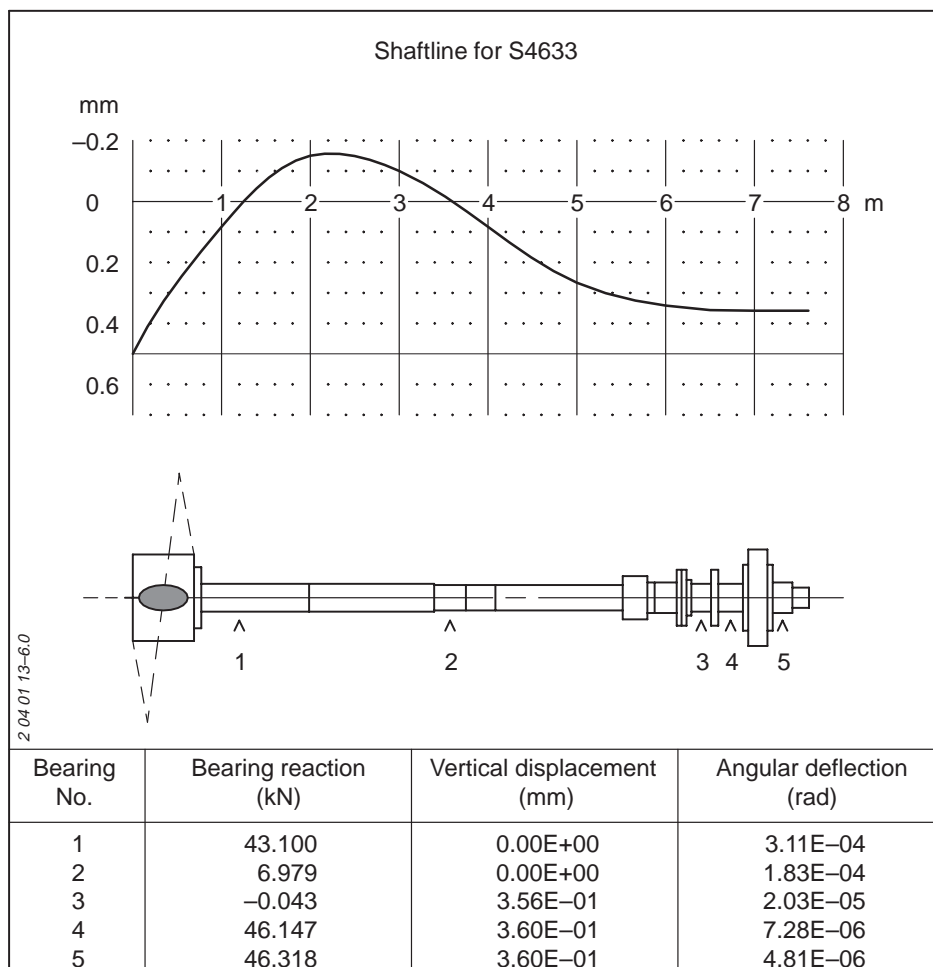

Fig 34: Calculated reactions and deflections in bearings

When propellers are delivered to another engine make than MAN B&W, a complete set of data necessary for performing the analysis is forwarded to the engine builder in question, fig 36.

**Whirling and axial vibration calculations**

Based on our experience the propeller equipment and shafting are designed considering a large safety margin against propeller induced whirl and axial vibrations. In case of plants with long intermediate shafting or stern posts carried by struts, a whirling analysis is made to ensure that the natural frequencies of the system are sufficiently outside the operating speed regime.

Propeller induced axial vibrations are generally of no concern but analysis of shafting systems can be carried out in accordance with Classification Society requirements.

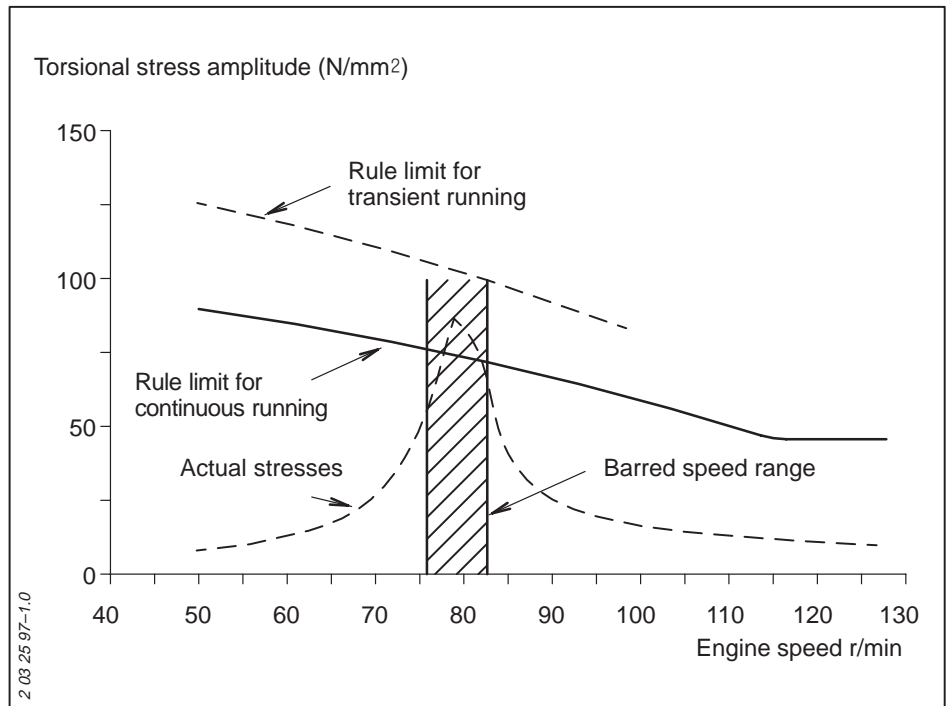

Fig 35: Torsional vibration calculation  
 Bulk carrier project 6S50MC 8,580 kW/127 r/min  
 Propeller shaft aft end (d= 460 mm/Ck = 0.55)

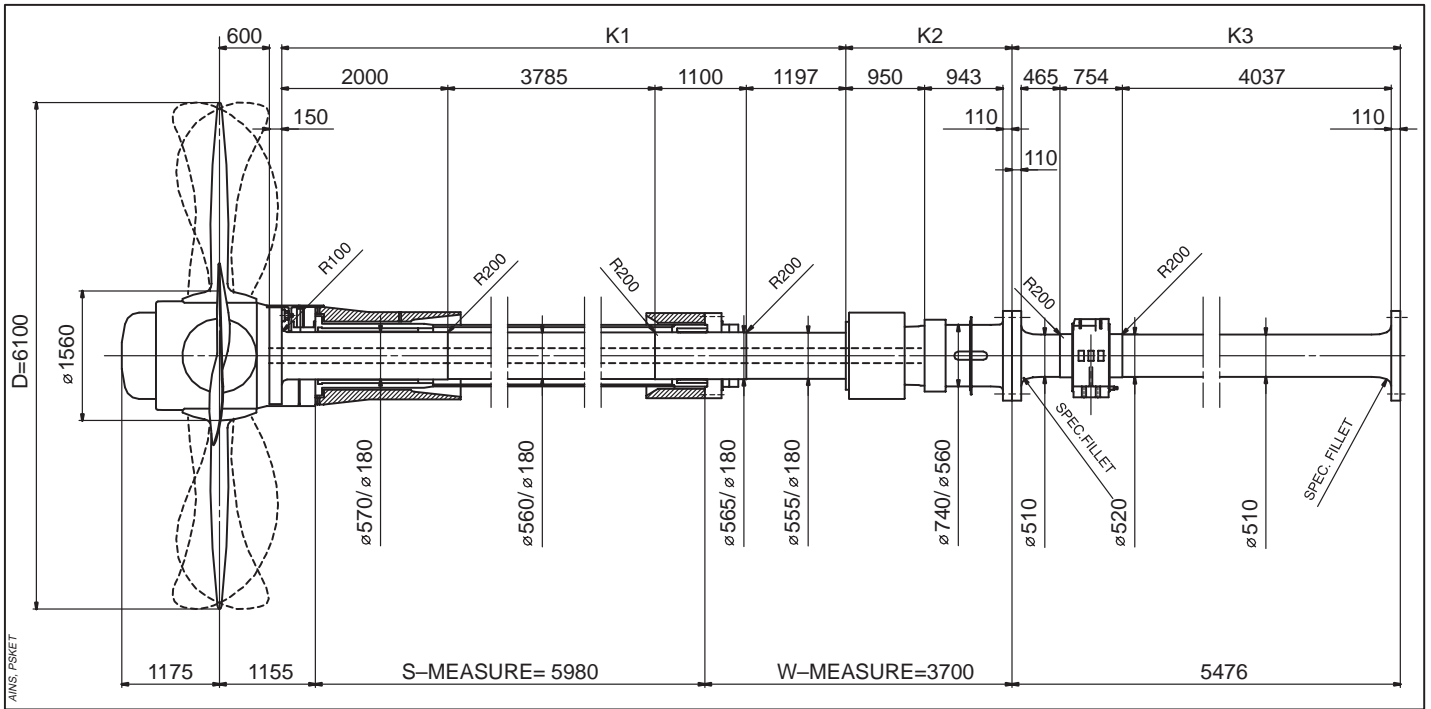

Fig 36: Propeller data for torsional vibration analysis

#### Propeller data

Inertia in air	kgm <sup>2</sup>	32900
Inertia in water (full pitch)	kgm <sup>2</sup>	39300
Inertia in water (zero pitch)	kgm <sup>2</sup>	34500
Number of blades		4
Propeller diameter	mm	6100
Design pitch		0.755
Expanded area ratio		0.48
Propeller weight (hub + blades)	kg	22230

#### Shaft data

Shaft section	Material	Tensile strength N/mm <sup>2</sup>	Yield strength N/mm <sup>2</sup>	Torsional stiffness MNm/rad
Propeller shaft	Forged steel	min 600	min 350	K1 99.0
Servo unit	Forged steel	min 740	min 375	K2 1105.0
Intermediate shaft	Forged steel	min 600	min 350	K3 105.6



## Main Dimensions

### Propeller equipment VB

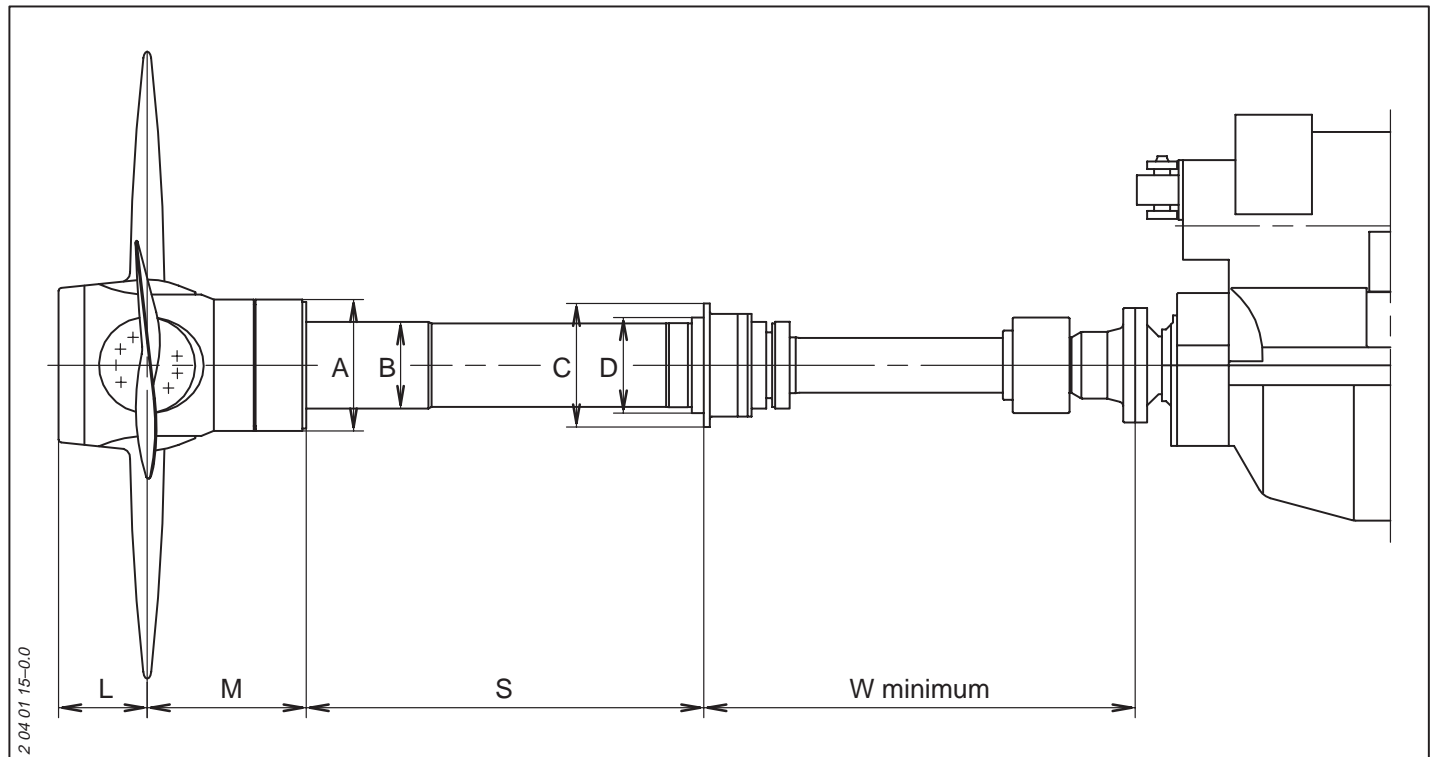

Hub type	Shaft diameter mm	A mm	B mm	C mm	D mm	L mm	M mm	W min mm
VB 480	180	390	280	440	340	270	508	850
VB 560	180	440	280	440	340	293	553	965
VB 560	200	440	315	440	340	293	553	900
VB 640	180	520	280	440	340	360	585	900
VB 640	200	520	305	440	345	360	585	900
VB 640	215	520	318	490	385	360	595	975
VB 640	245	520	381	560	440	360	600	1200
VB 740	215	580	318	490	385	415	651	1150
VB 740	245	580	381	560	440	415	655	1200
VB 740	275	580	400	590	475	415	655	1200
VB 860	245	660	381	560	440	445	745	1200
VB 860	275	660	400	590	475	445	745	1350
VB 860	300	660	430	590	475	445	745	1350
VB 980	300	710	430	590	475	584	800	1350
VB 980	325	710	447	700	575	584	820	1600
VB 980	350	710	475	700	575	584	820	1600

## Propeller equipment VBS

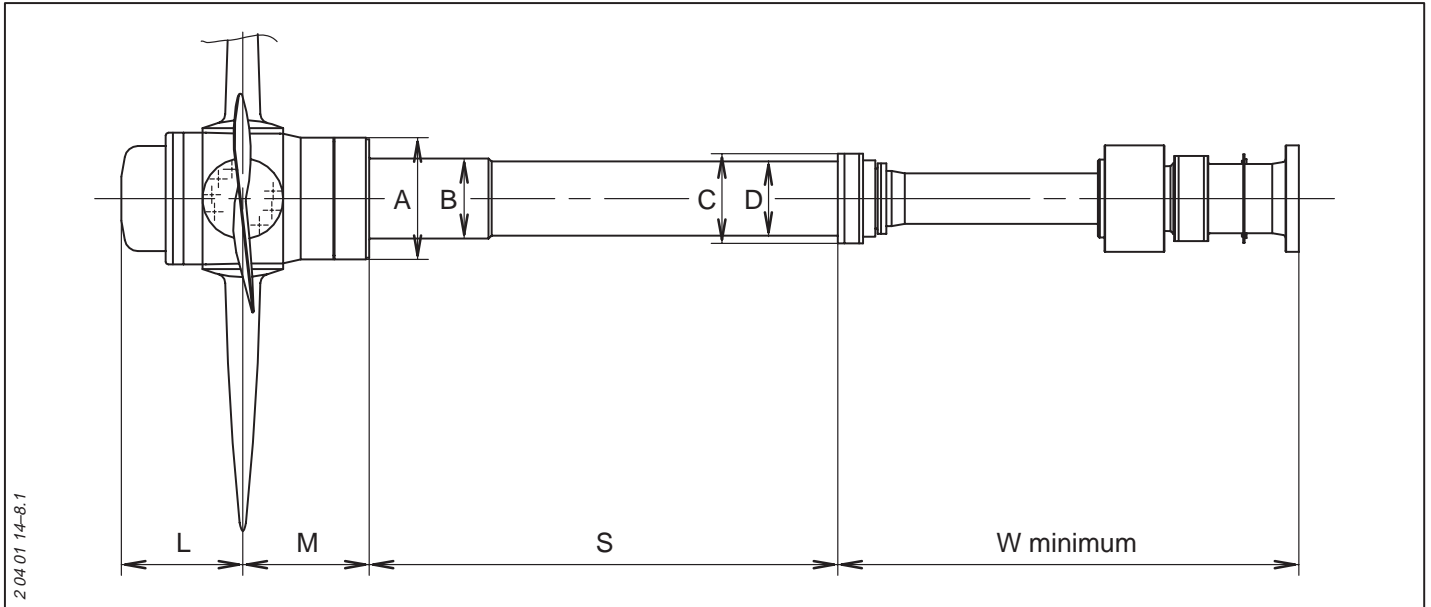

Hub type	Shaft diameter mm	OD-shaft mm	A mm	B mm	C mm	D mm	L mm	M mm	W min mm	W <sub>preferable</sub> mm
VBS 740	215	200	580	331	425	390	569	655	1760	2248
VBS 740	245	225	580	370	445	410	569	655	1760	2248
VBS 740	275	250	580	407	485	450	569	655	1970	2650
VBS 860	245	225	670	370	445	410	653	742	1760	2248
VBS 860	275	250	670	407	485	450	653	742	1970	2650
VBS 860	300	280	670	432	515	480	653	742	2000	2615
VBS 980	300	280	760	432	515	480	746	787	2000	2615
VBS 980	325	310	760	455	565	530	746	807	2040	2655
VBS 980	350	330	760	480	590	555	746	807	2170	2880
VBS 1080	325	310	840	455	565	530	821	880	2040	2655
VBS 1080	375	350	840	540	610	575	821	945	2170	2880
VBS 1080	400	375	840	545	630	595	821	945	2265	2975
VBS 1180	375	350	915	540	610	575	885	996	2170	2880
VBS 1180	400	375	915	545	630	595	885	996	2265	2975
VBS 1180	425	400	915	597	675	640	885	1021	2511	3241
VBS 1280	375	350	1000	540	610	575	957	1049	2170	2880
VBS 1280	425	400	1000	597	675	640	957	1075	2511	3241
VBS 1280	480	450	1000	647	755	720	957	1075	2676	3451
VBS 1380	425	400	1070	597	675	640	1030	1131	2511	3241
VBS 1380	450	425	1070	622	705	670	1030	1131	2651	3426
VBS 1380	480	450	1070	647	755	720	1030	1131	2676	3451
VBS 1460	450	425	1130	622	705	670	1100	1170	2651	3426
VBS 1460	480	450	1130	647	755	720	1100	1170	2676	3451
VBS 1460	510	475	1130	700	820	785	1100	1185	2595	3510
VBS 1560	480	450	1210	647	755	720	1175	1242	2676	3451
VBS 1560	510	475	1210	700	820	785	1175	1257	2595	3510
VBS 1560	560	510	1210	770	860	825	1175	1257	2919	3700
VBS 1680	510	475	1295	700	820	785	1278	1323	2595	3510
VBS 1680	560	510	1295	770	860	825	1278	1333	2919	3700
VBS 1680	625	560	1295	815	930	895	1278	1338	2976	3777

## Data Sheet for Propeller and Propulsion Plant

Identification: \_\_\_\_\_

Type of vessel: \_\_\_\_\_

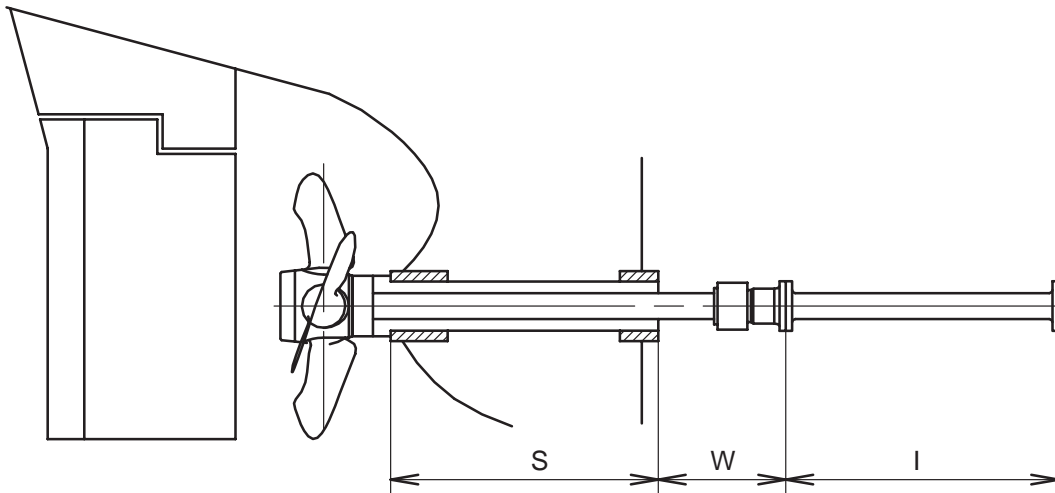

For propeller design purposes please provide us with the following information:

1. S: \_\_\_\_\_ mm W: \_\_\_\_\_ mm I: \_\_\_\_\_ mm (as shown above)

2. Stern tube and shafting arrangement layout

3. Propeller aperture drawing

4. Complete set of reports from model tank (resistance test, self-propulsion test and wake measurement). In case model test is not available the next page should be filled in.

5. Drawing of lines plan

6. Classification Society : \_\_\_\_\_

Ice class notation: \_\_\_\_\_

7. Maximum rated power of shaft generator: \_\_\_\_\_ kW

8. Optimisation condition for the propeller :

To obtain the highest propeller efficiency please identify the most common service condition for the vessel.

Ship speed : \_\_\_\_\_ kn Engine service load : \_\_\_\_\_ %

Service/sea margin : \_\_\_\_\_ % Shaft gen. service load : \_\_\_\_\_ kW

Draft : \_\_\_\_\_ m

9. Comments: \_\_\_\_\_  
 \_\_\_\_\_

## Data Sheet for Propeller and Propulsion Plant

(in case model test is not available this page should be filled in)

Identification: \_\_\_\_\_

Type of vessel: \_\_\_\_\_

### MAIN DIMENSIONS

	Symbol	Unit	Ballast	Loaded
Length between perpendiculars	$L_{PP}$	m		
Length of load water line	$L_{WL}$	m		
Breadth	B	m		
Draft at forward perpendicular	$T_F$	m		
Draft at aft perpendicular	$T_A$	m		
Displacement	$\nabla$	$m^3$		
Block coefficient ( $L_{PP}$ )	$C_B$	–		
Midship coefficient	$C_M$	–		
Waterplane area coefficient	$C_{WL}$	–		
Wetted surface with appendages	S	$m^2$		
Centre of buoyancy forward of $L_{PP}/2$	LCB	m		
Propeller centre height above baseline	H	m		
Bulb section area at forward perpendicular	$A_B$	$m^2$		

## Instruction Manual

As part of our technical documentation, an instruction manual will be forwarded. The instruction manual is tailor-made for each individual propeller plant and includes:

- Descriptions and technical data
- Operation and maintenance guidelines
- Spare parts plates













The manual can be supplied as a printed copy as well as an electronic book in English on CD-ROM.

The layout of the electronic book corresponds to the paperback book. In the electronic book it is possible to search for specific topics or words, zoom-in on diagrams and technical drawings, jump to references and to add personal notes. Parts of the book or the entire book can be printed out.

The electronic book is compatible with any standard PC Windows environment when using a special viewer which is part of the software on the CD-ROM.

VBS-propeller

**Table of Contents**

	05. Data .....
	10. Propeller equipment .....
	15. Propeller hub/shaft .....
	30. Servo installation parts .....
	35. Intermediate shaft .....
	40. Propeller nozzle .....
	45. Tools .....
	50. Servo system .....
	80. Instrumentation .....
	82. Remote control equipment .....
	84. Monitoring equipment .....
	86. Safety equipment .....
	90. Spare parts .....



The cover features the title 'Propeller Instruction Manual' and the MAN B&W logo. It includes a navigation menu with buttons for 'Contents...', 'Instructions', 'Data Sheets', 'Spare Parts', and 'How do I use this book'. The background shows a propeller hub and blades.

Release tac-vbs
